



COUNTY OF KENDALL, ILLINOIS
COMMITTEE OF THE WHOLE
County Office Building; Room 210; Yorkville IL
Thursday, November 15, 2018 at 4:00 PM
AGENDA

1. **Call to Order**
2. **Roll Call:** Matthew Prochaska, John Purcell, Bob Davidson, Elizabeth Flowers, Tony Giles, Judy Gilmour, Scott Gryder, Lynn Cullick, Matt Kellogg, Audra Hendrix
3. **Approval of Agenda**
4. **Approval of Claims in an amount not to exceed \$2,484,377.35, Coroner Claims in an amount not to exceed \$107.01, and November 6, 2018 Election Judge Claims in an amount not to exceed \$59,501.42**
5. **Department Head and Elected Official Reports**
6. **Items from Other Committees**
7. **Items of Business**

From the PBZ Committee:

Discussion of Amended Petition 17-28 Kendall County PBZ Committee

Request: Text Amendments to Sections 7.01.D.32 (Specials Uses in A-1 Agricultural District), 7.01.D.33 (Special Uses in A-1 Agricultural District) and 10.03.B.4 (Special Uses in M-3 Aggregate Materials Extraction, Processing and Site Reclamation District) of the Kendall County Zoning Ordinance Pertaining to Regulations of Outdoor Target Practice or Shooting Ranges (Not Including Private Shooting in Your Own Yard)

Discussion of Petition 18 – 04 Kendall County Regional Planning Commission

Request: Proposed Amendments to Future Land Use Map for Properties Located Near Route 47 in Lisbon Township

Discussion of Petition 18 – 13 Kendall County Planning, Building and Zoning Committee

Request: Text Amendments to Sections 3.02, 4.18, 7.01.D, 8.02.C, 8.03.H.1, 8.09.B, 9.02.C, 9.03.C, 9.04.C, 9.05.C, 9.06.F, 9.07.C, and 10.03.B of the Kendall County Zoning Ordinance by Amending Kendall County's Solar Panel Zoning Regulations

From the Budget & Finance Committee:

Discussion of FY2019 Budget

Discussion of FY2019 Budget Capital Projects

Discussion of Health Department Levy

8. **Public Comment**
9. **Questions from the Media**
10. **Action Items for County Board**
11. **Items for Committee of the Whole**
12. **Chairman's Report**
13. **Review Board Action Items**

**COUNTY OF KENDALL, ILLINOIS
COMMITTEE OF THE WHOLE
Thursday, October 11, 2018**

CALL TO ORDER AND PLEDGE OF ALLEGIANCE - The meeting was called to order at 4:15p.m. by Recording Clerk Valarie McClain who asked for nominations for a member to serve as chair of the meeting in the absence of County Board Chair Scott R. Gryder, and County Board Vice Chair Lynn Cullick.

Member Hendrix nominated Member Prochaska to fill the role as meeting chair, second by Member Gilmour. **With six members voting aye, the motion carried.**

ROLL CALL

Attendee	Status	Arrived	Left Meeting
Scott Gryder	ABSENT		
Lynn Cullick		5:46p.m.	
Bob Davidson	Yes		7:40p.m.
Elizabeth Flowers	ABSENT		
Tony Giles	ABSENT		
Judy Gilmour	Here		
Audra Hendrix	Here		
Matt Kellogg	Yes		
Matthew Prochaska	Here		
John Purcell	Present		

Others present: Latreese Caldwell, Assistant State’s Attorney Leslie Johnson, Scott Koeppel, Jim Smiley, Amaal Tokars, Raeann VanGundy

APPROVAL OF AGENDA – Motion made by Member Purcell to approve the agenda with the correction of adding the word *“Forwarding instead of Approval”* of Claims for approval in an amount not to exceed \$2,467,985.22, and Coroner Claims in an amount not to exceed \$5,480.13, second by Member Hendrix. **With six members present voting aye, the motion to approve the agenda as amended carried by a vote of 6-0.**

FORWARDING OF APPROVAL OF CLAIMS - Member Gilmour made a motion to forward the claims for approval in an amount not to exceed \$2,467,985.22, and Coroner Claims in an amount not to exceed \$5,480.13, second by Member Kellogg. **With six members present voting aye, the motion carried by a vote of 6-0.**

COMMITTEE BUSINESS

- *Presentation of County Office Building Security Options Study* – Jacob Been from Healy Bender reviewed the results of the Kendall County Office Building Security Options Study, briefed the committee on Healy Bender’s recommendations, and also reviewed the projected five-year work priority list and proposed budget costs for the completed project.

- *Update on Employee Healthcare Benefit Options* – Mr. Koeppel reported that the Horton Group was unavailable for this meeting, and that they would provide an update at the October 18, 2018 Admin HR Committee meeting.
- *Discussion of FY2019 Probation Funding* – Discussion of the pre-trial position salaries and benefits, the agreement by Probation/Court Services on November 24, 2014, to pay the benefits for the two Pre-Trial positions, whose salaries are paid through grant funding from the Administrative Office of the Illinois Courts, as well as Probation/Court Services history of also contributing funding toward the deficit short-fall between the state funding of these salaries and the actual amount paid by the County, and the history of the transfer of \$30,000 funds to off-set the cost of existing probation department employees since 2010, from the Probation fund to the General fund. The FY2019 transfer amount should be \$30,000 for the salary deficit, plus \$25,070 for the position benefits.
- *Discussion of Health Department Levy* – Discussion on various options for the distribution of the Health Department Levy, the Health Department personnel health insurance benefits, the health insurance, IMRF, and Social Security contribution expected for reimbursing the County each year, other services provided to the Health Department at no additional cost, such as technology services, payroll services, building maintenance and repair, building cleaning services, utilities, furniture and equipment, and discussion on other funding the Health Department receives annually such as the 708 Mental Health Levy, Senior Citizen Levy, and grant funding from various resurces.
- *FY 2019 Budget Discussion* – Discussion on the current preliminary budget deficit, the CPI, General Fund expenditures, Capital fund requests, the employee Health Insurance projections, the revenue numbers to date, the General Fund balance projection for FY2019, estimated revenues and expenditures for FY2018, the bond payment schedule and projected savings for the next several years, and the debt service fund.

PUBLIC COMMENT – Todd Milliron, Yorkville

QUESTIONS FROM THE MEDIA – None

ACTION ITEMS FOR THE OCTOBER 16, 2018 COUNTY BOARD MEETING

- *Approval of Claims in an amount not to exceed \$2,467,985.22, and Coroner Claims in an amount not to exceed \$5,480.13*
- *Discussion and Approval of Member Prochaska's Health Department Levy Proposal*

REVIEW BOARD ACTION ITEMS – Vice Chair Cullick asked the committee to review the draft County Board agenda for October 16, 2018.

ITEMS FOR THE NOVEMBER 15, 2018 COMMITTEE OF THE WHOLE MEETING - None

CHAIRMANS REPORT – No Report

EXECUTIVE SESSION – Member Hendrix made a motion to enter into Executive Session Executive Session for the purpose of the review of discussion of minutes of meetings lawfully closed under the Open Meetings Act, whether for purposes of approval by the body of the minutes or semi-annual review of the minutes as mandated by Section 2.06, 5ILCS 120-2, second by Member Purcell.

Roll Call: Member Hendrix - yes, Member Cullick – yes, Member Gilmour – yes, Member Kellogg - no, Member Prochaska – yes, Member Purcell - yes

With Members Cullick, Gilmour, Prochaska, Purcell and Hendrix voting aye, and Member Kellogg voting nay, the committee entered into Executive Session at 7:47p.m. by a vote of 5-1.

Committee Members Absent: Bob Davidson, Elizabeth Flowers, Tony Giles, Scott Gryder

Others Present: ASA Leslie Johnson, Scott Koeppel

The Committee reconvened in Open Session at 7:49p.m.

ADJOURNMENT – Member Prochaska made a motion to adjourn the meeting, second by Member Cullick. **With six members voting aye, the meeting was adjourned at 7:50p.m.**

Respectfully Submitted,

Valarie McClain
Administrative Assistant and Recording Secretary

Vendor#	Name	Invoice #	Description	Date	Budget #	Account Description	Dist	Amount	
FACILITIES MANAGEMENT									
1 060304	FIRST NATIONAL BANK OMAHA	55596	POSTAGE	11/20/18	01020016201	POSTAGE		3.95	cwald
								3.95*	
2 191312	JIM SMILEY	11082018	MILEAGE	11/20/18	01020016205	MILEAGE		125.51	cwald
3 230130	CHRISTINA WALD	11082018	MILEAGE	11/20/18	01020016205	MILEAGE		8.18	cwald
								133.69*	
4 012018	AT & T MOBILITY	X10282018	CELL PHONES	11/20/18	01020016207	CELLULAR PHONES		494.16	cwald
								494.16*	
5 010135	4 SEASONS LANDSCAPING	7274U	CONTRACTS	11/20/18	01020016214	ANNUAL CONTRACTS		6,718.78	cwald
6 010150	AAREN PEST CONTROL	29527	PEST CONTROL	11/20/18	01020016214	ANNUAL CONTRACTS		740.00	cwald
7 010455	ADVANCED ELEVATOR	44180	CONTRACTS	11/20/18	01020016214	ANNUAL CONTRACTS		1,427.71	cwald
8 011850	ARTLIP AND SONS INC	0008773	ANNUAL CONTRACTS	11/20/18	01020016214	ANNUAL CONTRACTS		5,780.00	cwald
9 031212	CLEANER LIVING SERVICES INC	K141	CLEANING	11/20/18	01020016214	ANNUAL CONTRACTS		16,185.12	cwald
10 191505	SOUND INCORPORATED	D1332276	TELEPHONE SOFTWARE U	11/20/18	01020016214	ANNUAL CONTRACTS		2,893.00	cwald
								33,744.61*	
11 011850	ARTLIP AND SONS INC	0193010	SERVICES	11/20/18	01020016215	CONTRACTUAL SERVICES		351.00	cwald
12 031212	CLEANER LIVING SERVICES INC	S1019	CLEANING	11/20/18	01020016215	CONTRACTUAL SERVICES		2,000.00	cwald
13 160177	PARK VENDING	51585-86 88-91	VENDING SERVICES	11/20/18	01020016215	CONTRACTUAL SERVICES		313.50	cwald
								2,664.50*	
14 201220	TRANE COMPANY	5197863	MAINTENANCE	11/20/18	01020016216	EQUIPMENT MAINTENANCE		177.38	cwald
								177.38*	
15 110531	KENDALL CO HIGHWAY DEPT	11082018	FUEL	11/20/18	01020016217	VEHICLE MAINT/GAS		94.30	cwald
								94.30*	
16 060304	FIRST NATIONAL BANK OMAHA	55596	SUPPLIES	11/20/18	01020016237	COUNTY SUPPLIES		552.01	cwald
17 071806	GRAINGER	18113071	SUPPLIES	11/20/18	01020016237	COUNTY SUPPLIES		62.36	cwald
18 081230	HCH CHEMICAL	543996	SUPPLIES	11/20/18	01020016237	COUNTY SUPPLIES		978.43	cwald
19 210020	ULTRA-CHEM, INC.	1221573	SUPPLIES	11/20/18	01020016237	COUNTY SUPPLIES		305.70	cwald
20 251493	YORKVILLE ACE & RADIO SHACK	167164	SUPPLIES	11/20/18	01020016237	COUNTY SUPPLIES		87.97	cwald
								1,986.47*	
Total FACILITIES MANAGEMENT								39,299.06*	
BUILDING AND ZONING									
21 020541	BUILDING & ZONING PETTY CASH	SEPTEMBER 2018	CMAP MEETING TRAIN A	11/20/18	01020026206	TRAINING		16.50	pherber
								16.50*	
22 220620	VERIZON	9816890994	CELL PHONE - CODE OF	11/20/18	01020026207	CELLULAR PHONE		55.62	pherber
								55.62*	
23 012290	AUTOMOTIVE SPECIALTIES INC	23225	2008 FORD COUNTY TRU	11/20/18	01020026217	VEHICLE MAINT/REPAIRS		90.45	pherber
24 012290	AUTOMOTIVE SPECIALTIES INC	23200	2017 CHEVY COUNTY TR	11/20/18	01020026217	VEHICLE MAINT/REPAIRS		105.03	pherber
25 110531	KENDALL CO HIGHWAY DEPT	OCTOBER 2018	OCTOBER FUEL - PBZ T	11/20/18	01020026217	VEHICLE MAINT/REPAIRS		127.49	pherber

Vendor#	Name	Invoice #	Description	Date	Budget #	Account Description	Dist	Amount	
26	160189	PARADISE CAR WASH	223786	COUNTY TRUCK WASHES	11/20/18	01020026217	VEHICLE MAINT/REPAIRS	11.00	pherber
								333.97*	
27	261005	RANDY ERICKSON	OCTOBER 2018	OCTOBER 2018 PLUMBING	11/20/18	01020026361	PLUMBING INSPECTIONS	1,400.00	pherber
								1,400.00*	
							Total BUILDING AND ZONING	1,806.09*	
COUNTY CLERK & RECORDER									
28	091215	ILLINOIS ASSOC. OF COUNTY CLER	ANNUAL DUES	2018-19 ANNUAL DUES	11/20/18	01020066203	DUES/MEMBERSHIPS	345.00	jhanna
								345.00*	
29	190816	SHAW MEDIA	10100046	PUBLICATIONS	11/20/18	01020066209	LEGAL PUBLICATIONS	67.38	** jhanna
								67.38*	
30	031552	COMTEX CUSTOM SOLUTIONS, INC.	6545	REMOTE SOFTWARE	11/20/18	01020066215	CONTRACTUAL SERVICES/CONS	990.50	** skraber
								990.50*	
							Total COUNTY CLERK & RECORDER	1,402.88*	
ELECTION COSTS									
31	030800	CHICAGO TRIBUNE	002053233000	ELECTION PUBLICATION	11/20/18	01020076209	LEGAL PUBLICATIONS	40.97	jhanna
32	190816	SHAW MEDIA	10100046	PUBLICATIONS	11/20/18	01020076209	LEGAL PUBLICATIONS	2,059.20	** jhanna
								2,100.17*	
33	031547	COMMUNITY OF CHRIST CHURCH	RENTAL	POLLING PLACE RENTAL	11/20/18	01020076424	POLLING PLACE/RENT/MISC E	55.00	jhanna
34	031848	CROSSPOINTE CHURCH	CROSSPOINTE	POLLING PLACE RENTAL	11/20/18	01020076424	POLLING PLACE/RENT/MISC E	100.00	jhanna
35	061570	FOX METRO WATER REC DIST	FOX METRO	POLLING PLACE RENTAL	11/20/18	01020076424	POLLING PLACE/RENT/MISC E	25.00	jhanna
36	120139	LAKWOOD PRAIRIE HOMEOWNERS AS	LAKWOOD	POLLING PLACE RENTAL	11/20/18	01020076424	POLLING PLACE/RENT/MISC E	200.00	jhanna
37	140552	NEW LIFE CHURCH	NEW LIFE	POLLING PLACE RENTAL	11/20/18	01020076424	POLLING PLACE/RENT/MISC E	50.00	jhanna
38	141590	OAK CREEK CLUBHOUSE	OAK CREEK	POLLING PLACE RENTAL	11/20/18	01020076424	POLLING PLACE/RENT/MISC E	100.00	jhanna
39	161209	UNITED METHODIST CHURCH OF PLA	UMC	POLLING PLACE RENTAL	11/20/18	01020076424	POLLING PLACE/RENT/MISC E	55.00	jhanna
40	192055	ST LUKES LUTHERAN CHURCH	ST. LUKE	POLLING PLACE RENTAL	11/20/18	01020076424	POLLING PLACE/RENT/MISC E	75.00	jhanna
								660.00*	
41	020310	PEYTON BAMMER	P.BAMMER	ELECTION HELP	11/20/18	01020076426	EXTRA HELP	75.00	jhanna
42	020918	CHARLES B. BIEBER	BIEBER:MILEAGE	ELECTION MILEAGE	11/20/18	01020076426	EXTRA HELP	292.67	jhanna
43	020919	CHARLES B BIEBER	B.BIEBER	ELECTION HELP	11/20/18	01020076426	EXTRA HELP	2,085.00	jhanna
44	020920	LORRAINE BIEBER	L.BIEBER	ELECTION HELP	11/20/18	01020076426	EXTRA HELP	300.00	jhanna
45	070942	JACK GILLETTE	J.GILLETTE	ELECTION HELP	11/20/18	01020076426	EXTRA HELP	25.00	jhanna
46	080129	MEGAN HANNA	M HANNA	ELECTION HELP	11/20/18	01020076426	EXTRA HELP	105.00	jhanna
47	160562	PARALEE M. PERKINS	P. PERKINS	ELECTION HELP	11/20/18	01020076426	EXTRA HELP	257.50	jhanna
48	161811	CONNIE PUNKE	C.PUNKE	ELECTION HELP	11/20/18	01020076426	EXTRA HELP	645.00	jhanna
49	230552	ADAM D. WEISBROOK	MILEAGE -1	MILEAGE	11/20/18	01020076426	EXTRA HELP	187.48	jhanna
50	230552	ADAM D. WEISBROOK	A WIESBROOK	ELECTION HELP	11/20/18	01020076426	EXTRA HELP	637.50	jhanna
51	268459	DANIELLE J. DELAY	D. DELAY	ELECTION HELP	11/20/18	01020076426	EXTRA HELP	172.50	jhanna
52	268460	JESSICA R. RACE	J.RACE	ELECTION HELP	11/20/18	01020076426	EXTRA HELP	147.50	jhanna
53	268469	BRODY FERKO	B. FERKO	ELECTION HELP	11/20/18	01020076426	EXTRA HELP	25.00	jhanna
54	268470	CALLIE FERKO	C.FERKO	ELECTION HELP	11/20/18	01020076426	EXTRA HELP	25.00	jhanna

Vendor#	Name	Invoice #	Description	Date	Budget #	Account Description	Dist	Amount	
55	268471	JACK STILLMUNKES	J. STILLMUNKES	ELECTION HELP	11/20/18	01020076426	EXTRA HELP	25.00	jhanna
56	268472	TONY HISAW	T. HISAW	ELECTION HELP	11/20/18	01020076426	EXTRA HELP	375.00	jhanna
57	268473	NATALIE JONES	N. JONES	ELECTION HELP	11/20/18	01020076426	EXTRA HELP	25.00	jhanna
58	268474	MALLORY JONES	M. JONES	ELECTION HELP	11/20/18	01020076426	EXTRA HELP	25.00	jhanna
59	268475	ANDY NGUYEN	A. NGUYEN	ELECTION HELP	11/20/18	01020076426	EXTRA HELP	57.23	jhanna
								5,487.38*	
60	050914	ELECTION SYSTEMS & SOFTWARE IN	1070255	ELECTION SUPPLIES	11/20/18	01020076427	ELECTION SUPPLIES	654.64	jhanna
61	091281	ILLINOIS OFFICE SUPPLY	55861	ELECTION SUPPLIES	11/20/18	01020076427	ELECTION SUPPLIES	668.70	jhanna
62	091281	ILLINOIS OFFICE SUPPLY	55918	ELECTION SUPPLIES	11/20/18	01020076427	ELECTION SUPPLIES	2,278.75	jhanna
63	110567	KENDALL PRINTING	18-1029-R	ELECTION SUPPLIES	11/20/18	01020076427	ELECTION SUPPLIES	18.00	jhanna
64	191522	SOURCE ONE OFFICE PRODUCTS	534336	ELECTION SUPPLIES	11/20/18	01020076427	ELECTION SUPPLIES	44.94	jhanna
65	191522	SOURCE ONE OFFICE PRODUCTS	534345	ELECTION SUPPLIES	11/20/18	01020076427	ELECTION SUPPLIES	47.24	jhanna
66	191527	SOUTHERN COMPUTER WAREHOUSE (S	00534905	ELECTION SUPPLIES	11/20/18	01020076427	ELECTION SUPPLIES	461.94	jhanna
								4,174.21*	
67	030182	FRANCISCO CARRENO III	F. CARRENO	POLLING PLACE SET UP	11/20/18	01020076428	POLLING PLACE - DELIVERY	800.00	jhanna
68	030184	ADAM CARRENO	A. CARRENO	POLLING PLACE SET UP	11/20/18	01020076428	POLLING PLACE - DELIVERY	800.00	jhanna
69	030185	MELISSA CARRENO	M. CARRENO	POLLING PLACE SET UP	11/20/18	01020076428	POLLING PLACE - DELIVERY	800.00	jhanna
70	130163	MARK'S AUTO SERVICE	21840	ELECTION	11/20/18	01020076428	POLLING PLACE - DELIVERY	129.44	jhanna
71	130197	ANNE MC WEENY	MCWEENY	POLLING PLACE SET UP	11/20/18	01020076428	POLLING PLACE - DELIVERY	100.00	jhanna
72	230979	LINDA WISSMILLER	L. WISSMILLER	POLLING PLACE SET UP	11/20/18	01020076428	POLLING PLACE - DELIVERY	60.00	jhanna
								2,689.44*	
Total ELECTION COSTS								15,111.20*	
EDUCATIONAL SERVICE REGION									
73	071890	GRUNDY-KENDALL SUPT	NOV 2018	BENEFITS & INSURANCE	11/20/18	01020086430	BENEFITS-REIMBURSED TO GR	917.50	
								917.50*	
74	071890	GRUNDY-KENDALL SUPT	NOV 2018	SALARIES	11/20/18	01020086431	SALARY REIMB FOR SUPERINT	5,195.42	
								5,195.42*	
Total EDUCATIONAL SERVICE REGION								6,112.92*	
SHERIFF									
75	060300	FIREARM ENGRAVING LLC	14416	ENGRAVING	11/20/18	01020096200	OFFICE SUPPLIES (SHERIFF)	38.00	tpage
76	061599	FOX VALLEY TROPHY & PROMOTIONS	35590	ENGRAVING	11/20/18	01020096200	OFFICE SUPPLIES (SHERIFF)	6.00	tpage
77	161660	PREMIER MAILING & PRINTING	152858	BUSINESS CARDS	11/20/18	01020096200	OFFICE SUPPLIES (SHERIFF)	120.00	tpage
78	191952	STAPLES ADVANTAGE	8051852412	OFFICE SUPPLIES	11/20/18	01020096200	OFFICE SUPPLIES (SHERIFF)	115.08	** tpage
79	191952	STAPLES ADVANTAGE	16999-5108	CABINET AND BOOKSHEL	11/20/18	01020096200	OFFICE SUPPLIES (SHERIFF)	686.19	tpage
80	230270	WCS PHOTOGRAPHY	KDLCO-18	PHOTOS X240	11/20/18	01020096200	OFFICE SUPPLIES (SHERIFF)	480.00	tpage
								1,445.27*	
81	060449	FEDEX	635479864	EXPRESS MAILING	11/20/18	01020096201	POSTAGE	7.31	tpage
82	060449	FEDEX	636232598	EXPRESS MAILINGS	11/20/18	01020096201	POSTAGE	14.78	tpage
								22.09*	

Vendor#	Name	Invoice #	Description	Date	Budget #	Account Description	Dist	Amount	
83	050918	ELAN FINANCIAL SERVICES	NOVEMBER 2018	HOTEL & DUES NASRO	11/20/18	01020096204	CONFERENCES/DUES (SHERIFF)	833.14	** tpage
84	091230	ILLINOIS LEAP	2019 MEMBERSHIP	MEMBERSHIP DUES	11/20/18	01020096204	CONFERENCES/DUES (SHERIFF)	40.00	tpage
85	110501	KENDALL COUNTY ASSOCIATION OF	514	MONTHLY MEETING	11/20/18	01020096204	CONFERENCES/DUES (SHERIFF)	160.00	tpage
								1,033.14*	
86	231605	WEX BANK	OCTOBER 2018	FUEL	11/20/18	01020096205	FUEL (SHERIFF)	2,550.99	** tpage
87	231605	WEX BANK	OCTOBER 2018	FUEL	11/20/18	01020096205	FUEL (SHERIFF)	2,452.24	** tpage
								5,003.23*	
88	050918	ELAN FINANCIAL SERVICES	NOVEMBER 2018	HOTEL & FREDPRYOR	11/20/18	01020096206	TRAINING (SHERIFF)	796.10	** tpage
89	091288	IL SHERIFF'S ASSOCIATION	5016	CIVIL PROCESS TRAINI	11/20/18	01020096206	TRAINING (SHERIFF)	225.00	tpage
90	120148	JASON LARSEN	K-9 TRAINING	K-9 TRAINING	11/20/18	01020096206	TRAINING (SHERIFF)	82.50	***
91	181604	ROSATI'S	11/01/2018	NIGHT TRAINING	11/20/18	01020096206	TRAINING (SHERIFF)	198.00	tpage
								1,301.60*	
92	200893	TRANSUNION RISK AND ALTERNATIV	OCTOBER 2018	INVESTIGATIONS	11/20/18	01020096215	CONTRACTUAL SERVICES/CONS	113.50	tpage
								113.50*	
93	031558	COMMUNICATIONS DIRECT INC	MULTI INVOICES	EQUIP MAINT.	11/20/18	01020096216	EQUIPMENT MAINTENANCE (SH	1,383.75	** tpage
94	091488	INTOXIMETERS	22584956	MOUTHPIECE X200	11/20/18	01020096216	EQUIPMENT MAINTENANCE (SH	62.85	tpage
								1,446.60*	
95	031587	COMMERCIAL TIRE SERVICE	110918	TIRES	11/20/18	01020096217	VEHICLE MAINTENANCE (SHER	4,222.20	tpage
96	071220	GJOVIK FORD, INC	OCTOBER	VEHICLE SERVICE	11/20/18	01020096217	VEHICLE MAINTENANCE (SHER	1,795.86	** tpage
97	191927	STAFFORD'S INC.	756586/1	SQUAD REPAIR	11/20/18	01020096217	VEHICLE MAINTENANCE (SHER	235.00	tpage
								6,253.06*	
98	151992	OSWEGO PRINTING SERVICES	74152	SHAKEDOWN FORM	11/20/18	01020096219	PRINTING	100.00	tpage
								100.00*	
99	050918	ELAN FINANCIAL SERVICES	NOVEMBER 2018	HERO 24/7	11/20/18	01020096240	UNIFORMS (SHERIFF)	590.00	** tpage
100	100158	JCM UNIFORMS, INC	749187	CORR. UNIFORMS	11/20/18	01020096240	UNIFORMS (SHERIFF)	126.98	tpage
101	150819	RAY O' HERRON	MULTI INVOICES	UNIFORMS	11/20/18	01020096240	UNIFORMS (SHERIFF)	1,656.07	tpage
								2,373.05*	
102	120128	LABSOURCE, INC.	7179774	GLOVES	11/20/18	01020096435	POLICE SUPPLIES	988.00	tpage
								988.00*	
103	050918	ELAN FINANCIAL SERVICES	NOVEMBER 2018	PELLETS	11/20/18	01020096436	WEAPONS/AMMO	541.32	** tpage
								541.32*	
104	200817	CHARLES THOMPSON	VEST 2018	VEST REIMBURSEMENT	11/20/18	01020096438	CONTRACT EXPENSES (SHERIF	500.00	tpage
								500.00*	
105	061599	FOX VALLEY TROPHY & PROMOTIONS	35626	PLAQUE	11/20/18	01020096439	INVESTIGATIONS	30.00	tpage
								30.00*	

Vendor#	Name	Invoice #	Description	Date	Budget #	Account Description	Dist	Amount	
Total SHERIFF								21,150.86*	
CORRECTIONS									
106	010453	ADVANCED CORRECTIONAL HEALTHCA	110618	MEDICAL SERVICES	11/20/18	01020106215	CONTRACTUAL SERVICES/CONS	14,829.00	tpage
107	031627	CONSOLIDATED CORRECTIONAL FOOD	22103118	FOOD SERVICE	11/20/18	01020106215	CONTRACTUAL SERVICES/CONS	14,211.23	tpage
								29,040.23*	
108	042169	JEAN DUNAHOE	TRANSPORT	TRANSPORT PER DIEM	11/20/18	01020106451	PRISONER TRANSPORT	76.50	tpage
109	071568	THOMAS GOODSPEED	PRISONER TRANS	TRANSPORT PER DIEM	11/20/18	01020106451	PRISONER TRANSPORT	76.50	tpage
								153.00*	
110	191952	STAPLES ADVANTAGE	8051852412	MEDICAL SUPPLIES	11/20/18	01020106455	MEDICAL EXPENSES	66.38	** tpage
								66.38*	
Total CORRECTIONS								29,259.61*	
MERIT COMMISSION									
111	110534	KENDALL CO HEALTH/HUMAN SERV	47856 & 47895	PSYCHOLOGICAL EVALX2	11/20/18	01020116459	MERIT COMMISSION	500.00	tpage
112	200535	THE BLUE LINE	37831	AD	11/20/18	01020116459	MERIT COMMISSION	99.00	tpage
								599.00*	
Total MERIT COMMISSION								599.00*	
EMA									
113	031495	COMCAST	102818	EMA SERVICES	11/20/18	01020126207	TELEPHONE	37.88	tpage
114	220624	VERIZON WIRELESS	9817079266	EMA CELL PHONES	11/20/18	01020126207	TELEPHONE	111.24	** tpage
								149.12*	
115	231605	WEX BANK	OCTOBER 2018	FUEL	11/20/18	01020126217	VEHICLE MAINT/REPAIRS	7,461.89	** tpage
								7,461.89*	
116	031518	COMMONWEALTH EDISON	101918	EMA SERVICES	11/20/18	01020126461	RADIO/SIREN MAINTENANCE	32.46	tpage
117	040917	DISH NETWORK	102518	EMA SERVICES	11/20/18	01020126461	RADIO/SIREN MAINTENANCE	78.53	tpage
								110.99*	
Total EMA								7,722.00*	
CIRCUIT COURT CLERK									
118	150611	OFFICE DEPOT	220424156001	OFC SUPPLIES-BREAKRO	11/20/18	01020146200	OFFICE SUPPLIES	70.62	ccollins
119	150611	OFFICE DEPOT	220424156001	OFC SUPPLIES-BREAKRO	11/20/18	01020146200	OFFICE SUPPLIES	82.01	ccollins
120	191522	SOURCE ONE OFFICE PRODUCTS	534257	OFC SUPPLY-CALC TAPE	11/20/18	01020146200	OFFICE SUPPLIES	76.36	ccollins
121	191522	SOURCE ONE OFFICE PRODUCTS	534395	OFC SUPPLY-LICENSE P	11/20/18	01020146200	OFFICE SUPPLIES	42.37	ccollins
122	191952	STAPLES ADVANTAGE	8051769274	OFC SUPPLY-RED ENVEL	11/20/18	01020146200	OFFICE SUPPLIES	94.74	ccollins
								366.10*	
123	031426	CARYN COLLINS	1105CC-01	POSTAGE-TRANSFER CAS	11/20/18	01020146201	POSTAGE	41.90	ccollins
								41.90*	

Vendor#	Name	Invoice #	Description	Date	Budget #	Account Description	Dist	Amount	
124	090118	ILLINOIS ASSOCIATION OF COUNTY	1105CC-02	CONFERENCE-FALL IACO	11/20/18	01020146204	CONFERENCES	700.00 ***	ccollins
								700.00*	
125	161649	PRECISE PRINTING NETWORK INC	0041584	PRINTED FORMS-1ST 6	11/20/18	01020146219	PRINTING FORMS	8,305.32	ccollins
								8,305.32*	
							Total CIRCUIT COURT CLERK	9,413.32*	
JURY COMMISSION									
126		11022018	GRAND JURY FOR 10/29	11/20/18	01020156154	GRAND JUROR PER DIEM & MI		18.56	lulloa
127		10292018GJ	GRAND JURY FOR 10/29	11/20/18	01020156154	GRAND JUROR PER DIEM & MI		13.16	lulloa
128		102918GJ	GRAND JURY FOR 10/29	11/20/18	01020156154	GRAND JUROR PER DIEM & MI		17.48	lulloa
129		102920189GJ	GRAND JURY FOR 10/29	11/20/18	01020156154	GRAND JUROR PER DIEM & MI		18.56	lulloa
130		10292018GJ	GRAND JURY FOR 10/29	11/20/18	01020156154	GRAND JUROR PER DIEM & MI		21.80	lulloa
131		10292018GJ	GRAND JURY FOR 10/29	11/20/18	01020156154	GRAND JUROR PER DIEM & MI		17.48	lulloa
132		10292018GJ	GRAND JURY FOR 10/29	11/20/18	01020156154	GRAND JUROR PER DIEM & MI		19.64	lulloa
133		10292018GJ	GRAND JURY FOR 10/29	11/20/18	01020156154	GRAND JUROR PER DIEM & MI		18.56	lulloa
134		10292018GJ	GRAND JURY FOR 10/29	11/20/18	01020156154	GRAND JUROR PER DIEM & MI		14.24	lulloa
135		10292018GJ	GRAND JURY FOR 10/29	11/20/18	01020156154	GRAND JUROR PER DIEM & MI		18.56	lulloa
136		10292018GJ	GRAND JURY FOR 10/29	11/20/18	01020156154	GRAND JUROR PER DIEM & MI		13.16	lulloa
137		10292018GJ	GRAND JURY FOR 10/29	11/20/18	01020156154	GRAND JUROR PER DIEM & MI		22.88	lulloa
138		10292018GJ	GRAND JURY FOR 10/29	11/20/18	01020156154	GRAND JUROR PER DIEM & MI		20.72	lulloa
139		10292018GJ	GRAND JURY FOR 10/29	11/20/18	01020156154	GRAND JUROR PER DIEM & MI		16.40	lulloa
140		10292018GJ	GRAND JURY FOR 10/29	11/20/18	01020156154	GRAND JUROR PER DIEM & MI		19.64	lulloa
								270.84*	
141	150611	OFFICE DEPOT	223908328001	JURY SUPPLIES	11/20/18	01020156200	OFFICE SUPPLIES	319.84	lulloa
								319.84*	
							Total JURY COMMISSION	590.68*	
CIRCUIT COURT JUDGE									
142	150611	OFFICE DEPOT	223886492001	CALENDAR/VISITOR BOO	11/20/18	01020166200	OFFICE SUPPLIES	114.65	lulloa
143	150611	OFFICE DEPOT	223905551001	CALENDAR/VISITOR BOO	11/20/18	01020166200	OFFICE SUPPLIES	12.86	lulloa
								127.51*	
144	120525	LAW OFFICE OF ANDREW NICKEL	10/26/18	APPOINTED CONFLICT C	11/20/18	01020166481	STATUTORY EXPENSES	1,188.00	lulloa
145	191280	ELVA A. SLEPICKA	NOVEMBER2018-18	IN HOUSE SPANISH INT	11/20/18	01020166481	STATUTORY EXPENSES	1,530.00	lulloa
146	201808	TRANSLATION TODAY NETWORK, INC	6943	TIGRIGNA INTERPRETER	11/20/18	01020166481	STATUTORY EXPENSES	614.78	lulloa
								3,332.78*	
147	180585	RESERVE ACCOUNT	11/01/2018	POSTAGE RESERVE ACCO	11/20/18	01020166550	PRE-PAID POSTAGE	10,000.00	lulloa
								10,000.00*	
							Total CIRCUIT COURT JUDGE	13,460.29*	
CORONER									
148	110501	KENDALL COUNTY ASSOCIATION OF	525	MONTHLY FEES	11/20/18	01020176203	DUES/MEMBERSHIPS	32.00	jpurcell
								32.00*	

Vendor#	Name	Invoice #	Description	Date	Budget #	Account Description	Dist	Amount	
149	110531	KENDALL CO HIGHWAY DEPT	OCT GAS 2018	GASOLINE - OCTOBER	11/20/18	01020176217	VEHICLE MAINTENANCE	38.78	jpurcell
								38.78*	
150	130480	MEDPRO WASTE DISPOSAL, LLC	135399	BIOHAZARD WASTE REMO	11/20/18	01020176495	BIO HAZARD DISPOSAL	99.23	jpurcell
								99.23*	
							Total CORONER	170.01*	
COMBINED COURT SERVICES									
151	230237	WAREHOUSE DIRECT WORKPLACE SOL	40708100	OFFICE SUPPLIES	11/20/18	01020186200	OFFICE SUPPLIES	32.15	mperrrot
152	230237	WAREHOUSE DIRECT WORKPLACE SOL	40729180	OFFICE SUPPLIES	11/20/18	01020186200	OFFICE SUPPLIES	58.94	mperrrot
153	230237	WAREHOUSE DIRECT WORKPLACE SOL	40780170	OFFICE SUPPLIES	11/20/18	01020186200	OFFICE SUPPLIES	23.89	mperrrot
154	230237	WAREHOUSE DIRECT WORKPLACE SOL	40930070	OFFICE SUPPLIES	11/20/18	01020186200	OFFICE SUPPLIES	1,512.02	mperrrot
								1,627.00*	
155	111513	KONICA MINOLTA	32598610	MNTHL CHG/NOV'18	11/20/18	01020186215	CONTRACTUAL SERVICES/CONS	163.00	mperrrot
156	111514	KONICA MINOLTA BUSINESS SOLUTI	9005033461	COPIES/SEPT'18	11/20/18	01020186215	CONTRACTUAL SERVICES/CONS	24.67	mperrrot
								187.67*	
157	222058	VISA	OCT'18	VEHICLE EXPENSES	11/20/18	01020186217	VEHICLE EXPENSE	193.71	** mperrrot
								193.71*	
158	180926	DAVID J. RICKERT, KANE CO TREA	NOV'18	JUV DET/OCT'18	11/20/18	01020186505	KANE JUVENILE DETENTION	15,120.00	mperrrot
								15,120.00*	
159	150630	OGLE CO DEPENDENT CHILDREN FUN	OCT'18	JUV B & C	11/20/18	01020186506	JUVENILE BOARD & CARE	5,487.00	mperrrot
								5,487.00*	
							Total COMBINED COURT SERVICES	22,615.38*	
PUBLIC DEFENDER									
160	191522	SOURCE ONE OFFICE PRODUCTS	534463	MISC OFFICE SUPPLIES	11/20/18	01020196200	OFFICE SUPPLIES	399.48	djenkins
								399.48*	
161	011805	A.R.D.C.	6208271	REGIS DUES/VC	11/20/18	01020196203	DUES/MEMBERSHIPS	385.00	djenkins
162	011805	A.R.D.C.	6320962	REGIS DUES/LL	11/20/18	01020196203	DUES/MEMBERSHIPS	385.00	djenkins
163	011805	A.R.D.C.	6274877	REGIS DUES/CT	11/20/18	01020196203	DUES/MEMBERSHIPS	385.00	djenkins
164	011805	A.R.D.C.	6309717	REGIS DUES/MM	11/20/18	01020196203	DUES/MEMBERSHIPS	385.00	djenkins
								1,540.00*	
165	021932	TIMOTHY BROWN, PSY D.	10-31-18	MURPHY/18CF176/173	11/20/18	01020196215	CONTRACTUAL SERVICES	1,100.00	djenkins
								1,100.00*	
166	120152	LANGUAGE LINE SERVICES	4428507	WOLDENKIDAN/17CF283	11/20/18	01020196511	INTERPRETER SERVICES	172.25	djenkins
								172.25*	
167	130750	LEXISNEXIS RISK SOLUTIONS	145059420181031	OCT PAY	11/20/18	01020196513	STATUTORY EXPENSES/INVEST	50.00	djenkins
								50.00*	

Vendor#	Name	Invoice #	Description	Date	Budget #	Account Description	Dist Amount	
Total PUBLIC DEFENDER							3,261.73*	
STATES ATTORNEY								
168 011805	A.R.D.C.	SAO 6	2019 ARDC DUES	11/20/18	01020206203	DUES/MEMBERSHIPS	4,092.00	jstroup
169 110131	KANE COUNTY BAR ASSOCIATION	SAO 4	DUES FOR 3 ATTORNEYS	11/20/18	01020206203	DUES/MEMBERSHIPS	405.00	jstroup
							4,497.00*	
170 091289	IL STATE'S ATTORNEY ASSOC	TRAINING	WINTER TRIANING CONF	11/20/18	01020206206	TRAINING	450.00 ***	
							450.00*	
171 220620	VERIZON	9816947443	CELL PHONES	11/20/18	01020206207	CELL PHONES	230.30	jstroup
							230.30*	
172 031497	LISA COFFEY	144/145	LEGAL SERVICES	11/20/18	01020206215	CONTRACTUAL SERVICES	3,000.00	jstroup
							3,000.00*	
173 220124	MARYANNE J. VALENZIO, CSR	SAO 2	10/28/18 GJ & TRANSC	11/20/18	01020206239	TRANSCRIPTS	772.00	jstroup
							772.00*	
174 110155	BRENDA KARALES	SAO 1	REIMBURSEMENT SUPPLI	11/20/18	01020206520	CHILD ADVOCACY ED	41.26	jstroup
							41.26*	
175 030880	CHRONICLE MEDIA, LLC	15897/15959	LEGAL NOTICES - JUVE	11/20/18	01020206521	TRIALS/HEARINGS	60.00	jstroup
176 060328	FIRST MIDWEST BANK	SAO 5	FEE FOR GJ SUBPOENA	11/20/18	01020206521	TRIALS/HEARINGS	33.75	jstroup
177 102109	JP MORGAN CHASE BANK, N.A.	SB975546-11	FEE FOR GRAND JURY S	11/20/18	01020206521	TRIALS/HEARINGS	174.87	jstroup
178 230531	ERIC WEIS	SAO 3	REIMBURSEMENT-WITNES	11/20/18	01020206521	TRIALS/HEARINGS	851.60	jstroup
							1,120.22*	
Total STATES ATTORNEY							10,110.78*	
BOARD OF REVIEW								
179 110567	KENDALL PRINTING	18-11025	OFFICE SUPPLIES	11/20/18	01020216200	OFFICE SUPPLIES	202.20	lstale
180 191522	SOURCE ONE OFFICE PRODUCTS	432353	OFFICE SUPPLIES	11/20/18	01020216200	OFFICE SUPPLIES	78.98	lstale
							281.18*	
Total BOARD OF REVIEW							281.18*	
SUPERVISOR OF ASSESSMENT								
181 191522	SOURCE ONE OFFICE PRODUCTS	432078	OFFICE SUPPLIES	11/20/18	01020226200	OFFICE SUPPLIES	66.92	srainert
							66.92*	
Total SUPERVISOR OF ASSESSMENT							66.92*	
COUNTY TREASURER								
182 110567	KENDALL PRINTING	002	ENVELOPES	11/20/18	01020256200	OFFICE SUPPLIES	1,024.60	skrabar
183 191522	SOURCE ONE OFFICE PRODUCTS	43181700	POUCHES	11/20/18	01020256200	OFFICE SUPPLIES	121.14	skrabar
							1,145.74*	

Vendor#	Name	Invoice #	Description	Date	Budget #	Account Description	Dist	Amount	
184 060499	JILL FERRO, COUNTY TREASURER	1118	MILEAGE	11/20/18	01020256205	MILEAGE		10.90	skraber
								10.90*	
185 190816	SHAW MEDIA	103118	DELINQUENT TAXES	11/20/18	01020256209	LEGAL PUBLICATIONS		3,440.00	skraber
								3,440.00*	
186 031552	COMTEK CUSTOM SOLUTIONS, INC.	6545	REMOTE SOFTWARE	11/20/18	01020256215	CONTRACTUAL SERVICES/CONS		990.50	** skraber
								990.50*	
						Total COUNTY TREASURER		5,587.14*	
	UNEMPLOYMENT COMPENSATION								
187 091262	IL DIR OF EMPLOYMENT SECURITY	0011	EMPLOYMENT SECURITY	11/20/18	01020266546	CONTRIBUTIONS/STATE UNEMP		3,206.00	skraber
								3,206.00*	
						Total UNEMPLOYMENT COMPENSATION		3,206.00*	
	EMPLOYEE HEALTH INSURANCE								
188 010185	BENEFITWALLET	HSA FUNDING	HSA FUNDING M. BRIGA	11/20/18	01020276547	HEALTH INSURANCE PREMIUMS		500.00	***
189 010185	BENEFITWALLET	A HUNT	HSA FUNDING: A HUNT	11/20/18	01020276547	HEALTH INSURANCE PREMIUMS		250.00	***
190 091425	INFINISOURCE BENEFIT SERVICES	90267475	ADMIN FEES	11/20/18	01020276547	HEALTH INSURANCE PREMIUMS		84.00	skraber
								834.00*	
						Total EMPLOYEE HEALTH INSURANCE		834.00*	
	PRE-PAID POSTAGE								
191 160980	PITNEY BOWES GLOBAL FINANCIAL	1009952203	POSTAGE SUPPLIES	11/20/18	01020296232	POSTAGE SUPPLIES		340.26	vmcclain
								340.26*	
						Total PRE-PAID POSTAGE		340.26*	
	OFFICE OF ADM SERVICES								
192 150611	OFFICE DEPOT	MULTI	OFFICE SUPPLIES	11/20/18	01020306200	OFFICE SUPPLIES		61.90	vmcclain
								61.90*	
193 060304	FIRST NATIONAL BANK OMAHA	KOEPPPEL	KOEPPPEL TRAINING	11/20/18	01020306204	CONFERENCES		375.00	** vmcclain
								375.00*	
194 150611	OFFICE DEPOT	MULTI	BOARD SUPPLIES	11/20/18	01020306237	COUNTY SUPPLIES		129.99	vmcclain
								129.99*	
195 190816	SHAW MEDIA	1597850	2019 BUDGET AD	11/20/18	01020306561	ADVERTISEMENTS		53.94	vmcclain
								53.94*	
						Total OFFICE OF ADM SERVICES		620.83*	
	GENERAL INSURANCE & BONDING								
196 141584	NOTARY PUBLIC ASSOCIATION OF I SHERIFF'S OFC		NOTARY RENEWALS	11/20/18	01020316576	NOTARIES		108.00	vmcclain
								108.00*	

Vendor#	Name	Invoice #	Description	Date	Budget #	Account Description	Dist	Amount	
Total GENERAL INSURANCE & BONDING								108.00*	
COUNTY BOARD									
197 010403	ADM SERVICES PETTY CASH	PSC EMP APP	EMP APP LUNCH	11/20/18	01020326199	MISCELLANEOUS		12.00	vmcclain
198 060304	FIRST NATIONAL BANK OMAHA	KOEPPPEL	PSC EMP LUNCH	11/20/18	01020326199	MISCELLANEOUS		324.08	** vmcclain
								336.08*	
199 060304	FIRST NATIONAL BANK OMAHA	KOEPPPEL	UCCI CONFERENCE	11/20/18	01020326204	CONFERENCES		230.52	** vmcclain
								230.52*	
200 031890	LYNN CULLICK	CULLICK - UCCI	UCCI METING - OCT 20	11/20/18	01020326205	MILEAGE		181.90	
201 061289	ELIZABETH E FLOWERS	FLOWERS-OCT 18	MILEAGE FOR OCTOBER	11/20/18	01020326205	MILEAGE		57.24	
202 110298	MATTHEW KELLOGG	KELLOG - OCT18	MILEAGE FOR OCTOBER	11/20/18	01020326205	MILEAGE		52.32	
203 130305	VALARIE MCCLAIN	EMP APP LUNCH	MILEAGE REIMB	11/20/18	01020326205	MILEAGE		37.49	vmcclain
204 161780	MATTHEW PROCHASKA	PROCHASKA	UCCI METING - OCT 20	11/20/18	01020326205	MILEAGE		187.25	
								516.20*	
Total COUNTY BOARD								1,082.80*	
TECHNOLOGY SERVICES									
205 190802	RYAN SHAIN	110118	IPSTA 2018	11/20/18	01020336204	CONFERENCES		194.50	*** ghaug
								194.50*	
206 190802	RYAN SHAIN	110118	IPSTA 2018	11/20/18	01020336205	MILEAGE		179.85	*** ghaug
								179.85*	
207 030468	CDW GOVERNMENT, INC.	PRB9411	SOPHOS CLOUD 3YR	11/20/18	01020336585	COMPUTER MAINT/SOFTWARE		4,960.09	ghaug
208 060319	FIRST NATIONAL BANK OMAHA	102018	ZOOM 10/2-11/1/18	11/20/18	01020336585	COMPUTER MAINT/SOFTWARE		14.99	** ghaug
209 130040	MNJ TECHNOLOGIES DIRECT, INC.	3631916	SOPHOS SERVICE RENEW	11/20/18	01020336585	COMPUTER MAINT/SOFTWARE		6,824.00	ghaug
210 130040	MNJ TECHNOLOGIES DIRECT, INC.	3632162	SOPHOS SANDSTORM SG	11/20/18	01020336585	COMPUTER MAINT/SOFTWARE		2,498.00	ghaug
211 130040	MNJ TECHNOLOGIES DIRECT, INC.	3634131	CENTRAL PHISH THREAT	11/20/18	01020336585	COMPUTER MAINT/SOFTWARE		4,730.00	ghaug
								19,027.08*	
212 191527	SOUTHERN COMPUTER WAREHOUSE (S	537404	APC-BK500 & BATTERIE	11/20/18	01020336586	COMPUTER MAINT/HARDWARE		1,018.55	ghaug
								1,018.55*	
213 161910	PROVEN IT	533797	TONERS	11/20/18	01020336587	PRINTER EXPENSE		315.67	ghaug
214 161910	PROVEN IT	534070	TONERS	11/20/18	01020336587	PRINTER EXPENSE		93.00	ghaug
215 161910	PROVEN IT	534680	TONERS	11/20/18	01020336587	PRINTER EXPENSE		154.33	ghaug
216 161910	PROVEN IT	534682	TONERS	11/20/18	01020336587	PRINTER EXPENSE		151.95	ghaug
217 161910	PROVEN IT	534690	TONERS	11/20/18	01020336587	PRINTER EXPENSE		154.33	ghaug
218 161910	PROVEN IT	534691	TONERS	11/20/18	01020336587	PRINTER EXPENSE		124.66	ghaug
219 161910	PROVEN IT	534693	TONERS	11/20/18	01020336587	PRINTER EXPENSE		76.92	ghaug
220 161910	PROVEN IT	434703	TONERS	11/20/18	01020336587	PRINTER EXPENSE		71.70	ghaug
221 161910	PROVEN IT	534709	TONERS	11/20/18	01020336587	PRINTER EXPENSE		121.50	ghaug
222 161910	PROVEN IT	534711	TONERS	11/20/18	01020336587	PRINTER EXPENSE		122.86	ghaug
223 161910	PROVEN IT	534714	TONERS	11/20/18	01020336587	PRINTER EXPENSE		81.30	ghaug
224 161910	PROVEN IT	534715	TONERS	11/20/18	01020336587	PRINTER EXPENSE		76.92	ghaug
225 161910	PROVEN IT	534716	TONERS	11/20/18	01020336587	PRINTER EXPENSE		93.00	ghaug

Vendor#	Name	Invoice #	Description	Date	Budget #	Account Description	Dist	Amount	
226	161910	PROVEN IT	534719	TONERS	11/20/18	01020336587	PRINTER EXPENSE	93.00	ghauge
227	161910	PROVEN IT	534720	TONERS	11/20/18	01020336587	PRINTER EXPENSE	145.75	ghauge
228	161910	PROVEN IT	534721	TONERS	11/20/18	01020336587	PRINTER EXPENSE	107.63	ghauge
229	161910	PROVEN IT	535905	TONER	11/20/18	01020336587	PRINTER EXPENSE	154.33	ghauge
230	161910	PROVEN IT	535906	TONER	11/20/18	01020336587	PRINTER EXPENSE	154.33	ghauge
231	161910	PROVEN IT	535909	TONER	11/20/18	01020336587	PRINTER EXPENSE	93.00	ghauge
232	161910	PROVEN IT	537315	TONER	11/20/18	01020336587	PRINTER EXPENSE	56.44	ghauge
233	161910	PROVEN IT	537699	TONER	11/20/18	01020336587	PRINTER EXPENSE	145.75	ghauge
234	161910	PROVEN IT	537999	TONER	11/20/18	01020336587	PRINTER EXPENSE	56.44	ghauge
								2,644.81*	
235	111513	KONICA MINOLTA	32598612	MONTHLY LEASE OCT 18	11/20/18	01020336588	COPIER EXPENSE	5,492.49	** ghauge
236	240570	XEROX CORPORATION	6474,9652	MAINTENANCE SEPTEMBE	11/20/18	01020336588	COPIER EXPENSE	114.60	ghauge
								5,607.09*	
237	012012	AT & T	3760524400	INTERNET 10/11-11/18	11/20/18	01020336589	INTERNET EXPENSE	1,155.83	ghauge
								1,155.83*	
							Total TECHNOLOGY SERVICES	29,827.71*	
PROPERTY TAX SERVICES									
238	040716	DEVNET INC	07117998	TAX SOFTWARE	11/20/18	01020416215	CONTRACTUAL SERVICES	31,565.72	skraber
								31,565.72*	
							Total PROPERTY TAX SERVICES	31,565.72*	
FAC MGT UTILITIES									
239	031532	COMMONWEALTH EDISON	22826	ELECTRIC	11/20/18	01020446710	ELECTRIC - ANNEX 2 BUILDI	22.82	cwald
								22.82*	
240	031532	COMMONWEALTH EDISON	45014	ELECTRIC	11/20/18	01020446713	ELECTRIC - ANNEX 3 BUILDI	45.01	cwald
								45.01*	
241	030525	CENTER POINT ENERGY GAS SERVIC	7051291	NATURAL GAS	11/20/18	01020446801	NATURAL GAS - PSC	2,883.29	cwald
								2,883.29*	
242	030525	CENTER POINT ENERGY GAS SERVIC	7051291	NATURAL GAS	11/20/18	01020446802	NATURAL GAS - COURTHOUSE	1,605.45	cwald
								1,605.45*	
243	140981	NICOR	86652922	NATURAL GAS	11/20/18	01020446805	NATURAL GAS - ANIMAL CONT	86.65	cwald
								86.65*	
244	140981	NICOR	651922	NATURAL GAS	11/20/18	01020446811	NATURAL GAS - FACILITIES/	100.65	cwald
								100.65*	
245	030525	CENTER POINT ENERGY GAS SERVIC	7051291	NATURAL GAS	11/20/18	01020446812	NATURAL GAS - HEALTH DEPA	636.97	cwald
								636.97*	

Vendor#	Name	Invoice #	Description	Date	Budget #	Account Description	Dist	Amount	
246	211432	UNITED CITY OF YORKVILLE	86827	WATER	11/20/18	01020446913	WATER - ANNEX 3 BUILDING	86.82	cwald
								86.82*	
Total FAC MGT UTILITIES								5,467.66*	
CAPITAL EXPENDITURES									
247	031922	CURRENT TECHNOLOGIES CORP.	8860	DELL EQUALLOGIC PS62	11/20/18	01021009133	TECHNOLOGY SERVICES	13,063.50	ghauge
								13,063.50*	
Total CAPITAL EXPENDITURES								13,063.50*	
CAPITAL IMPROVEMENT FUND - EXPENSE									
248	130290	PATRICK MCCANN INC.	1101	HCH WINDOW PROJECT	11/20/18	04020006650	EXPENSES	6,350.00	cwald
249	130290	PATRICK MCCANN INC.	1102	HCH WINDOW PROJECT	11/20/18	04020006650	EXPENSES	6,530.00	cwald
								12,880.00*	
Total CAPITAL IMPROVEMENT FUND - EK								12,880.00*	
LIABILITY INSURANCE EXPENSES									
250	191927	STAFFORD'S INC.	8827	SQUAD K26 REPAIR	11/20/18	10020006650	OTHER EXP. & DEDUCTIBLES	650.00	vmcclain
								650.00*	
Total LIABILITY INSURANCE EXPENSES								650.00*	
CO HWY FUND EXPENDITURES									
251	190816	SHAW MEDIA	1594421	PUBLIC NOTICE FUEL	11/20/18	12020006200	OFFICE SUPPLIES	84.94	ggates
252	191522	SOURCE ONE OFFICE PRODUCTS	534319	CALENDARS, PLANNERS,	11/20/18	12020006200	OFFICE SUPPLIES	246.11	ggates
								331.05*	
253	110517	KENDALL CO HIGHWAY PETTY CASH	10-KCHPC	PETTY CASH	11/20/18	12020006201	POSTAGE/FREIGHT	129.89	ggates
								129.89*	
254	011823	ARNESON TIRE CENTER, INC.	99264	TIRES #6	11/20/18	12020006216	EQUIPMENT MAINTENANCE	775.00	ggates
255	031521	COFFMAN TRUCK SALES INC	1001259169	TRUCKS TESTED & OIL	11/20/18	12020006216	EQUIPMENT MAINTENANCE	176.00	ggates
256	040538	DEKANE EQUIPMENT CORP	IA60888	PARTS FOR TRACTORS	11/20/18	12020006216	EQUIPMENT MAINTENANCE	364.36	ggates
257	050790	ELBURN NAPA, INC.	208510	PARTS	11/20/18	12020006216	EQUIPMENT MAINTENANCE	707.73	ggates
258	061027	FLEETPRIDE	13030365	NYLON UNION	11/20/18	12020006216	EQUIPMENT MAINTENANCE	34.47	ggates
259	061040	FEECE OIL CO.	1775714	OIL	11/20/18	12020006216	EQUIPMENT MAINTENANCE	116.20	ggates
260	091490	INTERSTATE BILLING SERVICE	3012442014	REGULATOR & BRAKES	11/20/18	12020006216	EQUIPMENT MAINTENANCE	1,267.33	ggates
261	101297	JOHN DEERE FINANCIAL	11113-35296	LATCH, SEAT ROLLER,	11/20/18	12020006216	EQUIPMENT MAINTENANCE	1,047.80	ggates
262	130506	MENARDS	31640257	TAPE, TURPENTINE, BO	11/20/18	12020006216	EQUIPMENT MAINTENANCE	294.29	ggates
263	180320	R&S DISTRIBUTING, INC.	R82632	TURBO CHARGER #10	11/20/18	12020006216	EQUIPMENT MAINTENANCE	975.00	ggates
264	200518	THE TURF TEAM	128987	CHAIN, CHAIN SAW, BL	11/20/18	12020006216	EQUIPMENT MAINTENANCE	387.87	ggates
265	220530	VERMEER MIDWEST	PC9251	HITCH	11/20/18	12020006216	EQUIPMENT MAINTENANCE	14.92	ggates
								6,160.97*	
266	050780	CHS ELBURN	255843	GAS / DIESEL	11/20/18	12020006217	GASOLINE/OIL	2,724.90	ggates
267	061040	FEECE OIL CO.	1775714	GAS / DIESEL	11/20/18	12020006217	GASOLINE/OIL	2,082.68	ggates
								4,807.58*	

Vendor#	Name	Invoice #	Description	Date	Budget #	Account Description	Dist	Amount		
268	060505	DENNIS FERGUSON	2019- DF	2019 CLOTHING ALLOWA	11/20/18	12020006240	CLOTHING ALLOWANCE	350.00	ggates	
269	081233	MIKE HOFFMAN	2019- MH	2019 CLOTHING ALLOWA	11/20/18	12020006240	CLOTHING ALLOWANCE	350.00	ggates	
270	110154	TIM KARALES	2019- TK	2019 CLOTHING ALLOWA	11/20/18	12020006240	CLOTHING ALLOWANCE	350.00	ggates	
271	120240	MATT LEEDY	2019- ML	2019 CLOTHING ALLOWA	11/20/18	12020006240	CLOTHING ALLOWANCE	350.00	ggates	
272	181568	ERIC ROSS	2019- ER	2019 CLOTHING ALLOWA	11/20/18	12020006240	CLOTHING ALLOWANCE	350.00	ggates	
273	190397	COREY SCHROEDER	2019- CS	2019 CLOTHING ALLOWA	11/20/18	12020006240	CLOTHING ALLOWANCE	350.00	ggates	
274	202135	JOHN TWAIT	2019- JT	2019 CLOTHING ALLOWA	11/20/18	12020006240	CLOTHING ALLOWANCE	350.00	ggates	
								2,450.00*		
275	030970	CITY OF YORKVILLE	0102017000-00	WATER/SEWER FEE	11/20/18	12020006251	UTILITIES	165.23	ggates	
								165.23*		
276	230143	WALMART BRC	2020-2022-1033	WATER	11/20/18	12020006720	BUILDING & GROUNDS MAINT	61.98	ggates	
								61.98*		
277	011354	AMEREN ILLINOIS	7484356018	MONTHLY SERVICE	11/20/18	12020006721	STREET LIGHTS MAINT	109.68	ggates	
278	031543	COMMONWEALTH EDISON	54016	MONTHLY SERVICE	11/20/18	12020006721	STREET LIGHTS MAINT	1,235.84	ggates	
279	071280	GO GREEN LED ALTERNATIVES	2018-1106	15 LED STREET LIGHTS	11/20/18	12020006721	STREET LIGHTS MAINT	5,626.05	ggates	
								6,971.57*		
280	131570	MORRIS ASPHALT DIVISION	778	COLD PATCH	11/20/18	12020006722	HIGHWAY MAINT MATERIALS	551.10	ggates	
281	191420	SNI SOLUTIONS	138649	BIO MELT	11/20/18	12020006722	HIGHWAY MAINT MATERIALS	1,100.00	ggates	
								1,651.10*		
282	040531	DECKER SUPPLY CO, INC	903412	POSTS	11/20/18	12020006724	SIGN SUPPLIES	2,252.81	ggates	
283	131090	MICHAEL TODD & COMPANY, INC.	163704	SPIN ALERTS	11/20/18	12020006724	SIGN SUPPLIES	1,812.10	ggates	
284	140590	NEWMAN TRAFFIC SIGNS	7188	SHEETING, CHEVRON, S	11/20/18	12020006724	SIGN SUPPLIES	2,066.05	ggates	
								6,130.96*		
285	050910	ELE INTERNATIONAL	11179849	CYLINDER MOLDS	11/20/18	12020006725	ENGR SUPPLIES & EXPENSE	85.15	ggates	
								85.15*		
286	201026	TRAFFIC CONTROL CORPORATION	109459	RED & GREEN LENS	11/20/18	12020006726	TRAFFIC SIGNAL MAINT.	388.00	ggates	
								388.00*		
								Total CO HWY FUND EXPENDITURES	29,333.48*	
COUNTY BRIDGE EXPENDITURE										
287	082176	HUTCHISON ENGINEERING, INC	18	ENG. - FRD OVER CLEA	11/20/18	13020006735	CONSTRUCTION OF BRIDGES	6,434.16	ggates	
288	091329	ILLINOIS RAILWAY, L.L.C.	10240	ANNUAL LEASE FEE 47'	11/20/18	13020006735	CONSTRUCTION OF BRIDGES	358.19	ggates	
289	230890	WILLETT HOFMANN & ASSOCIATES	25705	ENG. - GROVE RD. BRI	11/20/18	13020006735	CONSTRUCTION OF BRIDGES	1,066.20	ggates	
290	230890	WILLETT HOFMANN & ASSOCIATES	25705	BRIDGE INSPECTION FE	11/20/18	13020006735	CONSTRUCTION OF BRIDGES	2,073.90	ggates	
								9,932.45*		
								Total COUNTY BRIDGE EXPENDITURE	9,932.45*	
TRANSPORTATION SALES TAX EXP										
291	040230	"D" CONSTRUCTION INC	17-140 #2	PAY EST. #2 LITTLE R	11/20/18	19020006740	ROAD & BRIDGE CONSTRUCTIO	99,664.60	ggates	
								99,664.60*		

Vendor#	Name	Invoice #	Description	Date	Budget #	Account Description	Dist Amount	
292 110640	KHATER FAMILY, LLC	PARCEL 4	ROW - RIDGE RD./HOLT	11/20/18	19020006741	LAND ACQUISITION	52,000.00	ggates
293 110640	KHATER FAMILY, LLC	PARCEL 3	ROW - RIDGE RD./HOLT	11/20/18	19020006741	LAND ACQUISITION	85,000.00	ggates
294 230827	WHEATLAND TITLE GUARANTY CO.	599935	TITLE SEARCH FEE	11/20/18	19020006741	LAND ACQUISITION	416.00	ggates
295 268461	ERNEST WUNDERLICH FAMILY TRUST	2 - RIDGE	ROW - RIDGE/HOLT	11/20/18	19020006741	LAND ACQUISITION	52,500.00	ggates
296 268462	DOUGLAS F. SPESIA TRUST	2 - RIDGE	ROW - RIDGE/HOLT	11/20/18	19020006741	LAND ACQUISITION	52,500.00	ggates
							242,416.00*	
297 051451	ENGINEERING ENTERPRISES INC	65238	ENG. - QUIET ZONE CA	11/20/18	19020006742	ENGINEERING COST	2,479.75	ggates
298 060320	FIRST MIDWEST BANK	0001	RIDGE/HOLT LAND TRUS	11/20/18	19020006742	ENGINEERING COST	125.00	ggates
299 081544	HR GREEN INC.	11-122168	CONST. ENG. - RIVER	11/20/18	19020006742	ENGINEERING COST	39,339.61	ggates
300 230890	WILLETT HOFMANN & ASSOCIATES	25716	MILLINGTON BRIDGE SC	11/20/18	19020006742	ENGINEERING COST	935.85	ggates
301 230933	WBK ENGINEERING, LLC	19615	ENG. - COLLINS RD. E	11/20/18	19020006742	ENGINEERING COST	7,755.88	ggates
							50,636.09*	
Total TRANSPORTATION SALES TAX EXP							392,716.69*	
HEALTH & HUMAN SERV EXPENDITURES								
302 030490	CBHA CONFERENCE REGISTRATION	NOV	CBHA ANNUAL CONFEREN	11/20/18	21020006204	CONFERENCES & TRAINING	215.00	vrafatcz
303 080181	MARLIN HARTMAN	OCT	ILCSWMA BOARD MTG/SW	11/20/18	21020006204	CONFERENCES & TRAINING	95.11	vrafatcz
304 091370	IMVCA / RICH LAMPMAN	NOV	IMVCA ANNUAL MTG	11/20/18	21020006204	CONFERENCES & TRAINING	110.00	vrafatcz
305 110116	CINDY KATHE	NOV	CORNERSTONE FCM TRAI	11/20/18	21020006204	CONFERENCES & TRAINING	208.55	vrafatcz
							628.66*	
306 020470	CLARENCE BELL	OCT	OCT	11/20/18	21020006205	MILEAGE/BUSINESS EXP.	105.19	vrafatcz
307 020505	LAUREN BELVILLE	OCT	OCT	11/20/18	21020006205	MILEAGE/BUSINESS EXP.	98.11	vrafatcz
308 101351	ADAM JOHNSON	OCT	OCT	11/20/18	21020006205	MILEAGE/BUSINESS EXP.	106.83	vrafatcz
309 111002	NAOMI KNIGHT	OCT	OCT	11/20/18	21020006205	MILEAGE/BUSINESS EXP.	13.35	vrafatcz
310 130325	MARY MCCARRON-MCGINNISS	OCT	OCT	11/20/18	21020006205	MILEAGE/BUSINESS EXP.	36.41	vrafatcz
311 180127	VICTORIA RAFATCZ	OCT	OCT	11/20/18	21020006205	MILEAGE/BUSINESS EXP.	21.36	vrafatcz
312 190780	MARCIE SEJ	OCT	OCT	11/20/18	21020006205	MILEAGE/BUSINESS EXP.	8.07	vrafatcz
313 230156	RAEANN VANGUNDY	OCT	OCT	11/20/18	21020006205	MILEAGE/BUSINESS EXP.	403.41	vrafatcz
314 230204	ARISSA WALLIS	OCT	OCT	11/20/18	21020006205	MILEAGE/BUSINESS EXP.	124.37	vrafatcz
315 231605	WEX BANK	55614658	FUEL PURCHASES	11/20/18	21020006205	MILEAGE/BUSINESS EXP.	344.36	vrafatcz
							1,261.46*	
316 031553	COMMUNITY ANSWERING SERVICE	181000780	9/20/18 - 10/19/18	11/20/18	21020006215	CONTRACTUAL SERVICES	71.40	vrafatcz
317 080181	MARLIN HARTMAN	OCT	OCT HOURS	11/20/18	21020006215	CONTRACTUAL SERVICES	1,779.90	vrafatcz
							1,851.30*	
318 220623	VERIZON	OCT	OCT	11/20/18	21020006227	TELEPHONE	669.63	vrafatcz
							669.63*	
319 130325	MARY MCCARRON-MCGINNISS	OCT	OCT	11/20/18	21020006775	SUPPLIES - GENERAL	50.66	vrafatcz
320 130919	MIDWEST MEDICAL SUPPLY CO. LLC	15260100/152601	MICROCUVETTES/GAUZE	11/20/18	21020006775	SUPPLIES - GENERAL	385.60	vrafatcz
321 150611	OFFICE DEPOT	219239950001	YEAR COLOR CODE LABE	11/20/18	21020006775	SUPPLIES - GENERAL	15.64	vrafatcz
							451.90*	

Vendor#	Name	Invoice #	Description	Date	Budget #	Account Description	Dist	Amount	
322	011228	ALL SERVICE HEATING & AIR COND	102318	ES FURNACE	11/20/18	21020006781	DIRECT CLIENT ASSISTANCE	744.00	vrafatcx
323	011352	AMEREN IP	16444845	LIHEAP	11/20/18	21020006781	DIRECT CLIENT ASSISTANCE	4,252.00	vrafatcx
324	011820	ARNESON OIL CO.	INVOICE 164847	LIHEAP	11/20/18	21020006781	DIRECT CLIENT ASSISTANCE	1,971.00	vrafatcx
325	031508	COMMONWEALTH EDISON	INVOICE 164849	LIHEAP	11/20/18	21020006781	DIRECT CLIENT ASSISTANCE	50,710.00	vrafatcx
326	031508	COMMONWEALTH EDISON	INVOICE 164850	LIHEAP	11/20/18	21020006781	DIRECT CLIENT ASSISTANCE	40,622.00	vrafatcx
327	031508	COMMONWEALTH EDISON	INVOICE 164851	LIHEAP	11/20/18	21020006781	DIRECT CLIENT ASSISTANCE	16,866.00	vrafatcx
328	031546	CORN BELT ENERGY CORP	INVOICE 164852	LIHEAP	11/20/18	21020006781	DIRECT CLIENT ASSISTANCE	275.00	vrafatcx
329	080914	HICKSGAS BRAIDWOOD	INVOICE 164854	LIHEAP	11/20/18	21020006781	DIRECT CLIENT ASSISTANCE	5,668.00	vrafatcx
330	080916	HICKSGAS MARSEILLES	INVOICE 164855	LIHEAP	11/20/18	21020006781	DIRECT CLIENT ASSISTANCE	399.00	vrafatcx
331	140928	NICOR (ES)	INVOICE 164856	LIHEAP	11/20/18	21020006781	DIRECT CLIENT ASSISTANCE	28,398.00	vrafatcx
332	140928	NICOR (ES)	INVOICE 164857	LIHEAP	11/20/18	21020006781	DIRECT CLIENT ASSISTANCE	29,839.00	vrafatcx
333	190560	GRAINCO FS	INVOICE 164853	LIHEAP	11/20/18	21020006781	DIRECT CLIENT ASSISTANCE	5,875.00	vrafatcx
								185,619.00*	

Total HEALTH & HUMAN SERV EXPENDITURE 190,481.95*

FOREST PRESERVE EXPENDITURE

334	060304	FIRST NATIONAL BANK OMAHA	11/1/18:DG	HC-WATER, ADS, TONER	11/20/18	27020006200	OFFICE SUPPLIES & POSTAGE	730.58	** bantrim
335	091310	IL STATE POLICE	9/30/18	BACKGROUND CHECKS	11/20/18	27020006200	OFFICE SUPPLIES & POSTAGE	20.00	bantrim
336	111513	KONICA MINOLTA	32598612	MONTHLY LEASE OCT 18	11/20/18	27020006200	OFFICE SUPPLIES & POSTAGE	203.01	** ghaugc
								953.59*	
337	060304	FIRST NATIONAL BANK OMAHA	11/1/18:ED	ECOLOGY CONF	11/20/18	27020006204	CONFERENCES	184.00	** bantrim
338	060304	FIRST NATIONAL BANK OMAHA	11/1/18:DG	PESTICIDE TRAINING	11/20/18	27020006204	CONFERENCES	115.00	** bantrim
								299.00*	
339	031510	COMMONWEALTH EDISON	10/25/18:ARENA	HARRIS ARENA	11/20/18	27020006351	ELECTRIC	29.87	bantrim
340	031510	COMMONWEALTH EDISON	10/24/18:RY	RICHARD YOUNG	11/20/18	27020006351	ELECTRIC	33.62	bantrim
341	031510	COMMONWEALTH EDISON	10/16/18	BAKER WOODS	11/20/18	27020006351	ELECTRIC	23.66	bantrim
342	031510	COMMONWEALTH EDISON	11/2/18:JW	JAY WOODS	11/20/18	27020006351	ELECTRIC	33.12	bantrim
343	031510	COMMONWEALTH EDISON	10/25/18:HA	HARRIS	11/20/18	27020006351	ELECTRIC	69.19	bantrim
								189.46*	
344	190535	SELECTIVE INSURANCE CO. OF AME	FLD2059816	EL FLOOD INS RENEWAL	11/20/18	27020006838	INSURANCE REIMB	1,336.00	bantrim
								1,336.00*	
345	190816	SHAW MEDIA	10/31/18:SHAW	WEB HOST-JOB AD	11/20/18	27020006843	PROMOTION/PUBLICITY	250.15	bantrim
								250.15*	

Total FOREST PRESERVE EXPENDITURE 3,029.20*

ELLIS HOUSE

346	060304	FIRST NATIONAL BANK OMAHA	11/1/18:DG	EL-AT & T	11/20/18	27021007076	UTILITIES - ELLIS HOUSE	112.96	** bantrim
								112.96*	
347	060304	FIRST NATIONAL BANK OMAHA	11/1/18:MV	EL OFFICE SUPPLIES	11/20/18	27021007077	OFFICE SUPPLIES & POSTAGE	128.40	** bantrim
								128.40*	

Vendor#	Name	Invoice #	Description	Date	Budget #	Account Description	Dist	Amount	
348	010452	ADS, INC	SI-494143	EL ALARM INSPECTION	11/20/18	27021007080	GROUPS & MAINT - ELLIS H	209.30	** bantrim
349	020172	BARRETT'S ECOWATER	NOV 2018	EL WATER-NOV 2018	11/20/18	27021007080	GROUPS & MAINT - ELLIS H	25.00	bantrim
350	060304	FIRST NATIONAL BANK OMAHA	11/1/18:TV	EL-PAPER TOWELS	11/20/18	27021007080	GROUPS & MAINT - ELLIS H	43.46	** bantrim
351	130506	MENARDS	32073	EL SUPPLIES	11/20/18	27021007080	GROUPS & MAINT - ELLIS H	75.33	bantrim
352	130506	MENARDS	31311	EL SUPPLIES	11/20/18	27021007080	GROUPS & MAINT - ELLIS H	75.34	bantrim
353	130506	MENARDS	31569	EL SUPPLIES	11/20/18	27021007080	GROUPS & MAINT - ELLIS H	14.95	bantrim
								443.38*	
Total ELLIS HOUSE								684.74*	
ELLIS BARN									
354	010452	ADS, INC	SI-494143	EL ALARM INSPECTION	11/20/18	27021017080	GROUPS & MAINT - ELLIS B	209.30	** bantrim
355	161854	PROFESSIONAL GARAGE DOOR, INC	40361	EL DOOR REPAIRS	11/20/18	27021017080	GROUPS & MAINT - ELLIS B	124.00	bantrim
								333.30*	
Total ELLIS BARN								333.30*	
ELLIS GROUNDS									
356	060304	FIRST NATIONAL BANK OMAHA	11/1/18:TV	EL-SOAP, TOILET PAPE	11/20/18	27021027080	GROUPS & MAINT - ELLIS G	33.89	** bantrim
								33.89*	
Total ELLIS GROUNDS								33.89*	
ELLIS CAMPS									
357	051936	EQUINE VETERINARY PRACTICE LLC	0204916,22,23	EL - VET CARE	11/20/18	27021107084	VET & FARRIER - ELLIS CAM	253.68	** bantrim
358	101300	JOHN RYAN HORSESHOEING	10/31/18:VET	EL - VET CARE	11/20/18	27021107084	VET & FARRIER - ELLIS CAM	30.00	** bantrim
								283.68*	
Total ELLIS CAMPS								283.68*	
ELLIS RIDING LESSONS									
359	060304	FIRST NATIONAL BANK OMAHA	11/1/18:DG	EL-WOOD SHAVINGS	11/20/18	27021117082	ANIMAL CARE & SUPPLIES -	438.27	** bantrim
360	060304	FIRST NATIONAL BANK OMAHA	11/1/18:MV	EL PET SUPPLIES	11/20/18	27021117082	ANIMAL CARE & SUPPLIES =	34.51	** bantrim
								472.78*	
361	051936	EQUINE VETERINARY PRACTICE LLC	0204916,22,23	EL - VET CARE	11/20/18	27021117084	VET & FARRIER - ELLIS RID	253.66	** bantrim
362	101300	JOHN RYAN HORSESHOEING	10/31/18:VET	EL - VET CARE	11/20/18	27021117084	VET & FARRIER - ELLIS RID	150.00	** bantrim
								403.66*	
Total ELLIS RIDING LESSONS								876.44*	
ELLIS BIRTHDAY PARTIES									
363	051936	EQUINE VETERINARY PRACTICE LLC	0204916,22,23	EL - VET CARE	11/20/18	27021127084	VET & FERRIER - ELLIS B-D	253.66	** bantrim
364	101300	JOHN RYAN HORSESHOEING	10/31/18:VET	EL - VET CARE	11/20/18	27021127084	VET & FERRIER - ELLIS B-D	80.00	** bantrim
								333.66*	
365	190147	MICHELLE SALATO	10/30/18:MS	EL PROGRAM SUPPLIES	11/20/18	27021127087	PROG SUPPLIES = ELLIS B-D	39.20	bantrim
								39.20*	

Vendor#	Name	Invoice #	Description	Date	Budget #	Account Description	Dist Amount	
Total ELLIS BIRTHDAY PARTIES							372.86*	
ELLIS PUBLIC PROGRAMS								
366 060304	FIRST NATIONAL BANK OMAHA	11/1/18:MV	EL VOLUNTEER SUPPLIE	11/20/18	27021137079	VOLUNTEER EXP - ELLIS PUB	32.50 32.50*	** bantrim
Total ELLIS PUBLIC PROGRAMS							32.50*	
ELLIS WEDDINGS								
367 060304	FIRST NATIONAL BANK OMAHA	11/1/18:DG	ELLIS REFUSE P/U	11/20/18	27021207078	REFUSE PICKUP - ELLIS	117.66 117.66*	** bantrim
368 268446	NICOLE KANE	6/21/19-EL	EL SEC DEP CANCEL	11/20/18	27021207088	ELLIS SECURITY DEPOSIT RE	500.00	bantrim
369 268463	JENNIFER MENCHACA	10/21/18:EL	EL SEC DEP RTN	11/20/18	27021207088	ELLIS SECURITY DEPOSIT RE	325.00	bantrim
370 268464	REBECCA BOGDAN	10/20/18:EL	EL SEC DEP RTN	11/20/18	27021207088	ELLIS SECURITY DEPOSIT RE	1,000.00	bantrim
371 268465	AL MEISTER	10/27/18:EL	EL SEC DEP RTN	11/20/18	27021207088	ELLIS SECURITY DEPOSIT RE	455.00	bantrim
Total ELLIS WEDDINGS							2,280.00*	
HOOVER								
372 031510	COMMONWEALTH EDISON	10/30/18:BATH	HVR BATHHOUSE	11/20/18	27022006861	HOOVER - ELECTRIC	168.33	bantrim
373 031510	COMMONWEALTH EDISON	10/30/18:HVR	HVR MULTIPLIES	11/20/18	27022006861	HOOVER - ELECTRIC	691.20	bantrim
374 031510	COMMONWEALTH EDISON	10/30/18:HOUSE	HVR HOUSE	11/20/18	27022006861	HOOVER - ELECTRIC	62.77	bantrim
							922.30*	
375 101297	JOHN DEERE FINANCIAL	10/27/18	HVR-SUPPLIES	11/20/18	27022006863	HOOVER - SHOP SUPPLIES	16.93 16.93*	** bantrim
376 101297	JOHN DEERE FINANCIAL	10/27/18	HVR-SUPPLIES	11/20/18	27022006864	HOOVER - BUILDING MAINTEN	11.98 11.98*	** bantrim
377 060315	FIRST PLACE RENTAL	299524-1	HVR MANHOLE LOCATION	11/20/18	27022006865	HOOVER - GROUNDS MAINTENA	30.24	bantrim
378 101297	JOHN DEERE FINANCIAL	10/27/18	HVR-SUPPLIES	11/20/18	27022006865	HOOVER - GROUNDS MAINTENA	71.24 101.48*	** bantrim
379 071250	GARY GOLINSKI	18-00268	BUNKHOUSE SEC DEP RT	11/20/18	27022007088	HOOVER SECURITY DEPOSIT R	100.00	bantrim
380 100170	DIANE JASKOWSKI	18-00264	BUNKHOUSE SEC DEP RT	11/20/18	27022007088	HOOVER SECURITY DEPOSIT R	100.00	bantrim
381 110917	DANIEL KLEINWACHTER	18-00280	ML SEC DEP RTN	11/20/18	27022007088	HOOVER SECURITY DEPOSIT R	127.50	bantrim
382 122137	GUNTHER LUBBEN	18-00249	BUNKHOUSE SEC DEP RT	11/20/18	27022007088	HOOVER SECURITY DEPOSIT R	100.00	bantrim
383 267514	BILL GLASE	18-00281	BUNKHOUSE SEC DEP RT	11/20/18	27022007088	HOOVER SECURITY DEPOSIT R	100.00	bantrim
384 268466	VERDELL WILLIAMSON-PORTER	18-00233	BUNKHOUSE SEC DEP RT	11/20/18	27022007088	HOOVER SECURITY DEPOSIT R	100.00	bantrim
385 268467	BEVERLY LINKLATER	18-00245	BUNKHOUSE SEC DEP RT	11/20/18	27022007088	HOOVER SECURITY DEPOSIT R	100.00 727.50*	bantrim
Total HOOVER							1,780.19*	

Vendor#	Name	Invoice #	Description	Date	Budget #	Account Description	Dist	Amount	
ENVIRONMENTAL EDUCATION									
386 060304	FIRST NATIONAL BANK OMAHA	11/1/18:DG	AQUATIC NET	11/20/18	27023006849	ENVIRONMENTAL EDUCATION		237.11	** bantrim
387 268468	DENNIS BURGIN	DC102528	NB PRESENTION 10/18	11/20/18	27023006849	ENVIRONMENTAL EDUCATION		100.00	bantrim
								337.11*	
Total ENVIRONMENTAL EDUCATION								337.11*	
ENV ED SCHOOL									
388 060304	FIRST NATIONAL BANK OMAHA	11/1/18:ED	SCHOOL SUPPLIES	11/20/18	27023016849	ENV EDUC - SCHOOL PROG EX		34.75	** bantrim
								34.75*	
Total ENV ED SCHOOL								34.75*	
ENV ED NATURAL BEGINNINGS									
389 060304	FIRST NATIONAL BANK OMAHA	11/1/18:SW	NB SUPPLIES	11/20/18	27023036849	ENV EDUC - NATURAL BEGINN		229.65	bantrim
390 230034	JESSICA VOSBURGH	11/5/18:JV	NB SUPPLIES-PHOTOS,	11/20/18	27023036849	ENV EDUC - NATURAL BEGINN		40.08	bantrim
391 264915	TINA BRANNING	TB-10-29-18	NB SUPPLIES-PHOTOS	11/20/18	27023036849	ENV EDUC - NATURAL BEGINN		16.56	bantrim
								286.29*	
Total ENV ED NATURAL BEGINNINGS								286.29*	
ENV ED OTHER PUBLIC PROGRAMS									
392 060304	FIRST NATIONAL BANK OMAHA	11/1/18:ED	PUBLIC PROGRAMS SUPP	11/20/18	27023046849	ENV EDUC - OTHER PUBLIC P		29.19	** bantrim
								29.19*	
Total ENV ED OTHER PUBLIC PROGRAMS								29.19*	
ENV ED LAWS OF NATURE									
393 060304	FIRST NATIONAL BANK OMAHA	11/1/18:ED	PET SUPPLIES	11/20/18	27023056849	ENV EDUC - LAWS OF NATURE		17.92	** bantrim
								17.92*	
Total ENV ED LAWS OF NATURE								17.92*	
GROUNDS & NATURAL RESOURCES									
394 220626	VERIZON (FOREST PRESERVE)	9816784715	CELL PHONES	11/20/18	27025006207	TELEPHONE - GROUNDS & NAT		882.84	bantrim
								882.84*	
395 012061	ATLAS BOBCAT	BV9430	BOBCAT REPAIRS	11/20/18	27025006216	EQUIP - GROUNDS & NATURAL		465.31	bantrim
396 012290	AUTOMOTIVE SPECIALTIES INC	23227	'14 F-150 REPAIRS	11/20/18	27025006216	EQUIP - GROUNDS & NATURAL		64.56	bantrim
397 101297	JOHN DEERE FINANCIAL	10/27/18	EQUIP REPAIRS	11/20/18	27025006216	EQUIP - GROUNDS & NATURAL		116.48	** bantrim
								646.35*	
398 110531	KENDALL CO HIGHWAY DEPT	OCT 2018	GAS/DIESEL:OCT 2018	11/20/18	27025006217	FUEL - GAS & OIL		817.93	bantrim
								817.93*	
399 101297	JOHN DEERE FINANCIAL	10/27/18	BOOT ALLOW-P HIGGINS	11/20/18	27025006240	UNIFORMS		69.99	** bantrim
								69.99*	

Vendor#	Name	Invoice #	Description	Date	Budget #	Account Description	Dist Amount	
400 030540	CENTRAL LIMESTONE CO INC	15147	JAY WOODS TRAIL	11/20/18	27025006837	PRESERVE IMPROV - GR & NA	22.66	bantrim
401 030540	CENTRAL LIMESTONE CO INC	15365	JAY WOODS-IMPROVEMEN	11/20/18	27025006837	PRESERVE IMPROV - GR & NA	20.57	bantrim
402 030540	CENTRAL LIMESTONE CO INC	15253	PRESERVE IMPROVEMENT	11/20/18	27025006837	PRESERVE IMPROV - GR & NA	210.34	bantrim
							253.57*	
403 060304	FIRST NATIONAL BANK OMAHA	11/1/18:DG	HARRIS-REFUSE P/U	11/20/18	27025006847	REFUSE PICKUP - GROUNDS &	155.91	** bantrim
404 060304	FIRST NATIONAL BANK OMAHA	11/1/18:DG	HOOVER REFUSE P/U	11/20/18	27025006847	REFUSE PICKUP - GROUNDS &	113.66	** bantrim
405 190563	SERVICE SANITATION, INC	10/19/18	PORTABLE RESTROOMS	11/20/18	27025006847	REFUSE PICKUP - GROUNDS &	67.00	bantrim
							336.57*	
406 020507	BELSON OUTDOORS	WQ240682	DOGGIE BAGS	11/20/18	27025007089	SUPPLIES - SHOP	694.90	bantrim
407 101297	JOHN DEERE FINANCIAL	10/27/18	HA-SEAT, BATTERIES	11/20/18	27025007089	SUPPLIES - SHOP	73.75	** bantrim
							768.65*	
						Total GROUNDS & NATURAL RESOURCES	3,775.90*	
	Pickerill-Pigott Forest Preserve							
408 031510	COMMONWEALTH EDISON	10/23/18:PICKRI	PICKERILL	11/20/18	27026006351	ELECTRIC - PICKERILL PIGO	94.35	bantrim
							94.35*	
409 130506	MENARDS	31406	PICKERILL SUPPLIES	11/20/18	27026007089	SUPPLIES - PICKERILL PIGO	35.80	bantrim
							35.80*	
						Total Pickerill-Pigott Forest Preserve	130.15*	
	ANIMAL CONTROL EXPENDITURE							
410 230943	WILLIAMS SCOTSMAN	6156997	TRAILER LEASE	11/20/18	34020006650	BUILDING IMPROVEMENTS	310.49	pkeanemaxson
							310.49*	
						Total ANIMAL CONTROL EXPENDITURE	310.49*	
	ANIMAL MEDICAL CARE FUND							
411 031595	COUNTRYSIDE VETERINARY CLINIC	11012018	BOARD AND CARE	11/20/18	34120006902	ANIMAL MEDICAL CARE EXPEN	538.52	** pkeanemaxson
							538.52*	
						Total ANIMAL MEDICAL CARE FUND	538.52*	
	ANIMAL CONTROL EXPENSE							
412 191522	SOURCE ONE OFFICE PRODUCTS	431895	OFFICE SUPPLIES	11/20/18	35020006200	OFFICE SUPPLIES	75.92	pkeanemaxson
							75.92*	
413 110531	KENDALL CO HIGHWAY DEPT	NOV2018	VEHICLE EXPENSE	11/20/18	35020006217	VEHICLE EXPENSE & GASOLIN	14.40	pkeanemaxson
							14.40*	
414 110405	KETCHEM MFG. COMPANY, INC.	146497	RABIES TAGS	11/20/18	35020006896	RABIES TAGS	147.05	pkeanemaxson
							147.05*	

Vendor#	Name	Invoice #	Description	Date	Budget #	Account Description	Dist Amount	
Total ANIMAL CONTROL EXPENSE							237.37*	
CO RECORDER DOC STORAGE								
415 091319	IT STABILITY SYSTEMS, LLC	2018-166	MONTHLY SUPPLY & MAI	11/20/18	38020006650	DOC STORAGE EXPENSES	5,500.00	jhanna
416 140192	NAVIANT, INC	0136486-IN	OFFICE EQUIPMENT	11/20/18	38020006650	DOC STORAGE EXPENSES	9,060.00	jhanna
							14,560.00*	
Total CO RECORDER DOC STORAGE								
DRUG ABUSE EXPENDITURE FUND								
417 031249	CMC GOVERNMENT SUPPLY	SHERIFF	SHOTGUNS X4	11/20/18	40020006650	DRUG ABUSE PREVENTION	6,180.32	tpage
418 050918	ELAN FINANCIAL SERVICES	NOVEMBER 2018	SG SLING	11/20/18	40020006650	DRUG ABUSE PREVENTION	217.49	** tpage
							6,397.81*	
Total DRUG ABUSE EXPENDITURE FUND								
hidta								
419 021508	MICHAEL P. BOBKO	001120	HIDTA SERVICES	11/20/18	40120006650	OTHER	5,150.00	***
420 130224	VICTOR MARKOWSKI	0301033118-6	HIDTA SERVICES	11/20/18	40120006650	OTHER	32.70	tpage
							5,182.70*	
421 021508	MICHAEL P. BOBKO	19506366108	HIDTA SERVICES	11/20/18	40120007200	FACILITIES	22.24	tpage
							22.24*	
422 010395	ACTION K-9 SECURITY	MULTI INVOICES	HIDTA SERVICES	11/20/18	40120007201	SERVICES	2,750.00	tpage
423 010395	ACTION K-9 SECURITY	39506	HIDTA SERVICES	11/20/18	40120007201	SERVICES	700.00	tpage
424 011438	KENNETH ANGARONE	102218-11041821	HIDTA SERVICES	11/20/18	40120007201	SERVICES	4,657.69	tpage
425 012013	AT & T	312733072610	HIDTA SERVICES	11/20/18	40120007201	SERVICES	164.10	tpage
426 012136	AURORA POLICE DEPARTMENT	050818	HIDTA OT	11/20/18	40120007201	SERVICES	210.38	tpage
427 012136	AURORA POLICE DEPARTMENT	061318	HIDTA OT	11/20/18	40120007201	SERVICES	420.78	tpage
428 021090	BLOOMINGDALE POLICE DEPARTMENT	101818	HIDTA OT	11/20/18	40120007201	SERVICES	209.79	tpage
429 021508	MICHAEL P. BOBKO	001121	PROFESSIONAL SERVICE	11/20/18	40120007201	SERVICES	5,150.00	tpage
430 030965	CITY OF WOOD DALE POLICE DEPAR	032818	HIDTA OT	11/20/18	40120007201	SERVICES	210.60	tpage
431 031530	COM ED	MULTI INVOICES	HIDTA SERVICES	11/20/18	40120007201	SERVICES	2,129.27	tpage
432 041620	DOWNERS GROVE POLICE DEPARTMEN	02/20/18	HIDTA OT	11/20/18	40120007201	SERVICES	189.87	tpage
433 041620	DOWNERS GROVE POLICE DEPARTMEN	091318	HIDTA OT	11/20/18	40120007201	SERVICES	348.10	tpage
434 042177	DUPAGE COUNTY SHERIFF'S OFFICE	082918	HIDTA OT	11/20/18	40120007201	SERVICES	628.02	tpage
435 042177	DUPAGE COUNTY SHERIFF'S OFFICE	101618	HIDTA OT	11/20/18	40120007201	SERVICES	158.17	tpage
436 070905	SEAN GERAGHTY	102918-5	PROFESSIONAL SERVICE	11/20/18	40120007201	SERVICES	4,366.62	tpage
437 070905	SEAN GERAGHTY	111218-6	PROFESSIONAL SERVICE	11/20/18	40120007201	SERVICES	4,366.62	tpage
438 071202	GLENDALE HEIGHTS POLICE DEPART	032318	HIDTA OT	11/20/18	40120007201	SERVICES	406.62	tpage
439 071202	GLENDALE HEIGHTS POLICE DEPART	082418	HIDTA OT	11/20/18	40120007201	SERVICES	338.85	tpage
440 130223	VICTOR A. MARKOWSKI	031033118-8	HIDTA SERVICES	11/20/18	40120007201	SERVICES	7,081.25	tpage
441 160505	PEOPLES GAS	MULTI ACCOUNTS	HIDTA SERVICES	11/20/18	40120007201	SERVICES	337.74	tpage
442 181590	NICHOLAS J. ROTI	102908-24	PROFESSIONAL SERVICE	11/20/18	40120007201	SERVICES	6,356.96	tpage
443 181590	NICHOLAS J. ROTI	111218-25	PROFESSIONAL SERVICE	11/20/18	40120007201	SERVICES	6,356.96	tpage
444 200888	DAVID TORRES	101518-1	PROFESSIONAL SERVICE	11/20/18	40120007201	SERVICES	5,833.33	tpage
445 220620	VERIZON	HRS-OCT 2018	HIDTA SERVICES	11/20/18	40120007201	SERVICES	78.24	tpage
446 220901	VILLAGE OF LOMBARD POPLICE DEP	041718	HIDTA OT	11/20/18	40120007201	SERVICES	85.94	tpage

Vendor#	Name	Invoice #	Description	Date	Budget #	Account Description	Dist Amount	
447 220922	VILLAGE OF BENSENVILLE	033018	HIDTA OT	11/20/18	40120007201	SERVICES	206.10	tpage
448 220922	VILLAGE OF BENSENVILLE	101218	HIDTA OT	11/20/18	40120007201	SERVICES	206.10	tpage
449 220924	VILLAGE OF CAROL STREAM POLICE	033018	HIDTA OT	11/20/18	40120007201	SERVICES	225.58	tpage
							54,173.68*	
450 091278	IL SECRETARY OF STATE POLICE	SURVEILLANCE	TITLE AND PLATES	11/20/18	40120007202	EQUIPMENT	196.00	tpage
							196.00*	
Total hidta							59,574.62*	
KENDALL CO COMMISSARY FUND								
451 021503	BOB BARKER CO INC	NC1001447113	JUMPSUIT	11/20/18	40320006454	INMATE SUPPLIES	176.96	tpage
452 050774	ECOLAB	1391662,1391686	INMATE SUPPLIES	11/20/18	40320006454	INMATE SUPPLIES	1,120.15	tpage
							1,297.11*	
453 040724	DREYER CLINIC , INC.	258832	INMATE MEDICAL	11/20/18	40320006455	INMATE MEDICAL	26.15	tpage
454 050918	ELAN FINANCIAL SERVICES	NOVEMBER 2018	INMATE RK	11/20/18	40320006455	INMATE MEDICAL	9.99	** tpage
455 061035	FITZSIMMONS HOSPITAL SERVICES	50825	INMATE MEDICAL	11/20/18	40320006455	INMATE MEDICAL	441.75	tpage
456 070188	GARCIA CLINICAL LABORATORY	44962 / 44962A	INMATE MEDICAL	11/20/18	40320006455	INMATE MEDICAL	121.00	** tpage
457 070188	GARCIA CLINICAL LABORATORY	45981	LAB SERVICES	11/20/18	40320006455	INMATE MEDICAL	8.00	tpage
458 071841	GREEN TREE PHARMACY	239744	INMATE MEDICAL	11/20/18	40320006455	INMATE MEDICAL	994.59	** tpage
459 130343	MCKESSON MEDICAL-SURGICAL	5347156	INMATE MEDICAL	11/20/18	40320006455	INMATE MEDICAL	94.43	tpage
460 160480	PEARLVIEW DENTAL	MULTI INVOICES	INMATE MEDICAL	11/20/18	40320006455	INMATE MEDICAL	1,009.17	tpage
							2,705.08*	
Total KENDALL CO COMMISSARY FUND							4,002.19*	
COOK COUNTY REIMB FUND								
461 070188	GARCIA CLINICAL LABORATORY	44962 / 44962A	COOK INMATE	11/20/18	40520006455	MEDICAL EXPENSES	18.00	** tpage
462 071841	GREEN TREE PHARMACY	239744	COOK INMATE	11/20/18	40520006455	MEDICAL EXPENSES	281.30	** tpage
							299.30*	
Total COOK COUNTY REIMB FUND							299.30*	
IDOT CPS Grant								
463 051964	EVENFLO COMPANY INC	IN/2481954	CAR SEATS	11/20/18	40820006650	IDOT CPS GRANT - EXPENSES	4,458.18	tpage
							4,458.18*	
Total IDOT CPS Grant							4,458.18*	
COURT SECURITY FUND								
464 071220	GJOVIK FORD, INC	OCTOBER	CS VEHICLE SERVICE	11/20/18	42020006650	EXPENSES	39.78	** tpage
465 220624	VERIZON WIRELESS	9817079266	CS CELL PHONES	11/20/18	42020006650	EXPENSES	112.98	** tpage
							152.76*	
Total COURT SECURITY FUND							152.76*	

Vendor#	Name	Invoice #	Description	Date	Budget #	Account Description	Dist	Amount	
LAW LIBRARY FUND									
466	180560	RELX INC. DBA LEXISNEXIS	3091719369	PATRON LEGAL RESEARC	11/20/18	43020007004	ONLINE LEGAL RESEARCH PAT	1,075.00 1,075.00*	lulloa
467	180560	RELX INC. DBA LEXISNEXIS	3091710225	COURTHOUSE LEGAL RES	11/20/18	43020007005	ONLINE LEGAL RESEARCH COU	1,836.00 1,836.00*	lulloa
Total LAW LIBRARY FUND								2,911.00*	
PROBATION SERVICES EXP FUND									
468	130550	CHRIS MEYERS	OCT'18	PO REIMB.	11/20/18	48020006206	TRAINING	30.86	mperrot
469	191513	BRENDA SORENG	OCT'18	PO REIMB.	11/20/18	48020006206	TRAINING	19.79	mperrot
470	220482	BRIAN VAN METER	OCT'18	PO REIMB	11/20/18	48020006206	TRAINING	27.61	mperrot
471	222058	VISA	OCT'18	TRAINING	11/20/18	48020006206	TRAINING	2,511.27	** mperrot
472	230750	CHASE WETENKAMP	OCT'18	PO REIMB.	11/20/18	48020006206	TRAINING	19.11	mperrot
473	230836	JORDAN WHITE	OCT'18	PO REIM	11/20/18	48020006206	TRAINING	17.55	mperrot
								2,626.19*	
474	060181	FAMILY COUNSELING SERVICE	102018	TRMNT/EVALS/OCT'18	11/20/18	48020006214	CONTRACTUAL SERVICES - PR	3,745.00	mperrot
475	110534	KENDALL CO HEALTH/HUMAN SERV	47502	708 MENTAL HEALTH PS	11/20/18	48020006214	CONTRACTUAL SERVICES - PR	168.00	mperrot
476	222058	VISA	OCT'18	CLIENT UBER	11/20/18	48020006214	CONTRACTUAL SERVICES - PR	93.51	** mperrot
								4,006.51*	
477	222058	VISA	OCT'18	PHONE BILL	11/20/18	48020006215	CONTRACTUAL SERVICES - OT	415.87	** mperrot
								415.87*	
478	031831	CROWN TROPHY	15595	PLAQUES	11/20/18	48020006216	EQUIPMENT	192.50	mperrot
479	080551	HENRICKSEN & COMPANY	88110343	OFFICE FURNITURE	11/20/18	48020006216	EQUIPMENT	18,678.30	mperrot
480	091750	ITSAVVY LLC	01061759	HP PRINTER	11/20/18	48020006216	EQUIPMENT	267.76	mperrot
481	222058	VISA	OCT'18	EQUIPMENT	11/20/18	48020006216	EQUIPMENT	164.69	** mperrot
								19,303.25*	
482	191504	SOLUTION SPECIALTIES INC	MULTIPLES	TRACKER/OCT'18	11/20/18	48020006231	SOFTWARE	3,859.32	mperrot
								3,859.32*	
483	180428	REDWOOD TOXICOLOGY LAB	7239201810	DRUG TESTING	11/20/18	48020006915	DRUG TESTING	1,203.73	mperrot
484	180429	REDWOOD BIOTECH	662698	DT SUPPLIES	11/20/18	48020006915	DRUG TESTING	1,894.50	mperrot
485	230237	WAREHOUSE DIRECT WORKPLACE SOL	40641241	DT SUPPLIES	11/20/18	48020006915	DRUG TESTING	166.06	mperrot
486	230237	WAREHOUSE DIRECT WORKPLACE SOL	40930300	DRUG TEST GLOVES	11/20/18	48020006915	DRUG TESTING	368.00	mperrot
								3,632.29*	
487	190127	SATELLITE TRACKING OF PEOPLE,	54742	GPS/OCT'18	11/20/18	48020006916	GPS MONITORING PROGRAM	5,017.75	mperrot
								5,017.75*	
Total PROBATION SERVICES EXP FUND								38,861.18*	
ST ATTY DRUG ENFORCE EXP FUND									
488	161660	PREMIER MAILING & PRINTING	152720	PENS	11/20/18	50020006650	DRUG ABUSE PREVENTION	275.00 275.00*	jatroup

Vendor#	Name	Invoice #	Description	Date	Budget #	Account Description	Dist	Amount	
Total ST ATTY DRUG ENFORCE EXP FUND								275.00*	
GEOGRAPHIC INFORMATION SYS EXP									
489	012012	AT & T	3163094400	INTERNET 9/19-10/18	11/20/18	51020006215	CONTRACT SERVICES/CONSULT	1,103.06 1,103.06*	ghauge
490	060319	FIRST NATIONAL BANK OMAHA	102018	PAPER PLOTTER	11/20/18	51020006537	PLOTTER SUPPLIES	273.92 273.92*	** ghauge
491	021911	BRUCE HARRIS & ASSOCIATES	78544	BHA FARMLAND TOOLS A	11/20/18	51020006585	SOFTWARE	900.00 900.00*	ghauge
492	060319	FIRST NATIONAL BANK OMAHA	102018	TV/DISPLAY MONITOR	11/20/18	51020006586	HARDWARE	279.98	** ghauge
493	091750	ITSAVVY LLC	01066265	AIRTAME ADAPTER & ET	11/20/18	51020006586	HARDWARE	250.12	ghauge
494	191527	SOUTHERN COMPUTER WAREHOUSE (S	53630907	HP LASERJET PRINTER	11/20/18	51020006586	HARDWARE	3,863.15	ghauge
495	191527	SOUTHERN COMPUTER WAREHOUSE (S	537737	COMPUTER WORKSTATION	11/20/18	51020006586	HARDWARE	1,311.93	ghauge
496	191527	SOUTHERN COMPUTER WAREHOUSE (S	537715	SSD GIS WORKSTATION	11/20/18	51020006586	HARDWARE	50.77 5,755.95*	ghauge
Total GEOGRAPHIC INFORMATION SYS E								8,032.93*	
KENDALL AREA TRANSIT FUND EXP									
497	040517	DEKALB CO VOLUNTARY ACTION CEN MUNI CONTRIB		MUNICIPAL CONTRIBUTI	11/20/18	55020007050	DVAC	11,957.00 11,957.00*	vmcclain
Total KENDALL AREA TRANSIT FUND EXP								11,957.00*	
ADMIN DEBT SERVICE									
498	011309	AMALGAMATED BANK OF CHICAGO	4723	INTEREST	11/20/18	56020006865	ADMIN DEBT SERVICE INTERE	58,752.50 58,752.50*	skraber
499	011309	AMALGAMATED BANK OF CHICAGO	4723	PRINCIPAL	11/20/18	56020006870	ADMIN DEBT SERVICE PRINCI	175,000.00 175,000.00*	skraber
Total ADMIN DEBT SERVICE								233,752.50*	
JAIL EXP. BOND DEBT EXP									
500	011309	AMALGAMATED BANK OF CHICAGO	4318	INTEREST	11/20/18	58020006865	JAIL EXP. DEBT SERVICE I	109,200.00 109,200.00*	skraber
501	011309	AMALGAMATED BANK OF CHICAGO	4318	PRINCIPAL	11/20/18	58020006870	JAIL EXP. DEBT SERVICE P	1,025,000.00 1,025,000.00*	skraber
Total JAIL EXP. BOND DEBT EXP								1,134,200.00*	
ENGINEERING/CONSULTING ESCROW ACCT									
502	230933	WBK ENGINEERING, LLC	19611	STOR-MOR MINI STORAG	11/20/18	59020000037	STOR-MOR 16-20	94.50 94.50*	pherber

Vendor#	Name	Invoice #	Description	Date	Budget #	Account Description	Dist	Amount	
503	230933	WBK ENGINEERING, LLC	19612	FOX METRO EXPANSION	11/20/18	59020000046	FOX METRO WATER REC DIST	551.40	pherber
								551.40*	
504	230933	WBK ENGINEERING, LLC	19613	NICOR - MINOOKA	11/20/18	59020000059	NICOR-AUX SABLE CREEK-CO	477.88	pherber
								477.88*	
Total ENGINEERING/CONSULTING ESCROW								1,123.78*	
PUBLIC SAFETY EXP									
505	031558	COMMUNICATIONS DIRECT INC	MULTI INVOICES	SQUAD BUILD	11/20/18	75020006651	VEHICLES	11,170.00	** tpage
								11,170.00*	
506	011850	ARTLIP AND SONS INC	0193168	PSC ROOFING PROJECT	11/20/18	75020006653	MAINTENANCE/EQUIPMENT	694.00	cwald
507	231030	WOLD ARCHITECTS & ENGINEERS	59687	PSC ROOF PROJECT	11/20/18	75020006653	MAINTENANCE/EQUIPMENT	345.27	cwald
								1,039.27*	
Total PUBLIC SAFETY EXP								12,209.27*	
SHERIFF FTA FUND									
508	012050	AT&T MOBILITY (SHERIFF)	X10282018	CELL PHONES	11/20/18	84020006650	FTA FUND EXPENSE	103.76	tpage
509	220624	VERIZON WIRELESS	9817079266	CELL PHONES/DATA CAR	11/20/18	84020006650	FTA FUND EXPENSE	2,769.90	** tpage
								2,873.66*	
Total SHERIFF FTA FUND								2,873.66*	
COURTHOUSE RENOVATIONS									
510	192058	KAREN STONE	18-00048	COURT ROOM SEC DEP R	11/20/18	85020006650	EXPENDITURES	100.00	bantrim
								100.00*	
Total COURTHOUSE RENOVATIONS								100.00*	
COUNTY ANIMAL POPULATION CONTROL									
511	031595	COUNTRYSIDE VETERINARY CLINIC	NOV2018	SPAY/NEUTER DOGSCATS	11/20/18	87020006650	SPAY/NEUTER DOGS&CATS	10.00	pkeanemaxon
512	031595	COUNTRYSIDE VETERINARY CLINIC	11012018	SPAY/NEUTER CATSDOGS	11/20/18	87020006650	SPAY/NEUTER DOGS&CATS	80.00	** pkeanemaxon
								90.00*	
Total COUNTY ANIMAL POPULATION CONT								90.00*	
VETERANS ASSISTANCE COMMISSION									
513	060323	FIRST NATIONAL BANK OMAHA	2018-382	UBER REIMB - PREVIUO	11/20/18	89020006200	OFFICE SUPPLIES	-13.94	kclevanger
514	060323	FIRST NATIONAL BANK OMAHA	2018-382	OFFICE SUPPLIES VACK	11/20/18	89020006200	OFFICE SUPPLIES	18.16	kclevanger
515	060323	FIRST NATIONAL BANK OMAHA	2018-383	OFFICE SUPPLIES VACK	11/20/18	89020006200	OFFICE SUPPLIES	15.74	kclevanger
								19.96*	
516	091227	IACVAC	2018-367	IACVAC DUES	11/20/18	89020006203	STATE MEMBERSHIP FEES	225.00	kclevanger
								225.00*	

Vendor#	Name	Invoice #	Description	Date	Budget #	Account Description	Dist Amount		
517	060323	FIRST NATIONAL BANK OMAHA	2018-383	YORKVILLE AREA CHAMB	11/20/18	89020006204	LOCAL CONFERENCES	450.00	kclevenger
518	060323	FIRST NATIONAL BANK OMAHA	2018-383	YORKVILLE AREA CHAMB	11/20/18	89020006204	LOCAL CONFERENCES	100.00	kclevenger
							550.00*		
519	060323	FIRST NATIONAL BANK OMAHA	2018-381	VERIZON HOTSPOT	11/20/18	89020006215	PROFESSIONAL SERVICES	38.01	kclevenger
							38.01*		
520	111513	KONICA MINOLTA	2018-364	KONICA - LEASE	11/20/18	89020006216	EQUIPMENT MAINTENANCE	138.00	kclevenger
521	111514	KONICA MINOLTA BUSINESS SOLUTI	2018-365	KONICA - MAINTENANCE	11/20/18	89020006216	EQUIPMENT MAINTENANCE	50.23	kclevenger
							188.23*		
522	110531	KENDALL CO HIGHWAY DEPT	2018-366	FUEL - OCTOBER	11/20/18	89020006217	VACKC VEHICLES - FUEL	353.86	kclevenger
							353.86*		
523	060323	FIRST NATIONAL BANK OMAHA	2018-382	WIX - WEBSITE VACKC	11/20/18	89020006231	COMPUTER, PERIPHERALS & S	93.90	kclevenger
							93.90*		
524	060901	FIDELITY BANK	2018-358	SHELTER - MCDADE	11/20/18	89020006595	SHELTER ASSISTANCE	300.00	kclevenger
525	080105	RON HABBE	2018-361	SHELTER - SANFORD	11/20/18	89020006595	SHELTER ASSISTANCE	400.00	kclevenger
526	130045	M & T BANK	2018-359	SHELTER - MOODY	11/20/18	89020006595	SHELTER ASSISTANCE	500.00	kclevenger
527	130969	MILL STREET STATION	2018-355	SHELTER- GRAZIANO	11/20/18	89020006595	SHELTER ASSISTANCE	400.00	kclevenger
528	130969	MILL STREET STATION	2018-363	SHELTER - WILSON	11/20/18	89020006595	SHELTER ASSISTANCE	500.00	kclevenger
529	150470	WILLIAM ODENBACH	2018-362	SHELTER - WEBER	11/20/18	89020006595	SHELTER ASSISTANCE	400.00	kclevenger
530	161204	PLANO LAND HOLDINGS	2018-360	SHELTER - MURRAY	11/20/18	89020006595	SHELTER ASSISTANCE	300.00	kclevenger
531	201810	TRI COUNTY PROPERTY MANAGE IN	2018-356	SHELTER - LIKENESS	11/20/18	89020006595	SHELTER ASSISTANCE	300.00	kclevenger
532	251508	YORKVILLE LEASED HOUSING ASSOC	2018-357	SHELTER - MCCULLOUGH	11/20/18	89020006595	SHELTER ASSISTANCE	500.00	kclevenger
							3,600.00*		
533	011370	AMEREN ILLINOIS	2018-375	UTILITY ASSISTANCE S	11/20/18	89020006596	UTILITY ASSISTANCE	71.98	kclevenger
534	031541	COM ED	2018-369	UTILITY ASSISTANCE H	11/20/18	89020006596	UTILITY ASSISTANCE	25.91	kclevenger
535	031541	COM ED	2018-370	UTILITY ASSISTANCE G	11/20/18	89020006596	UTILITY ASSISTANCE	60.77	kclevenger
536	031541	COM ED	2018-372	UTILITY ASSISTANCE M	11/20/18	89020006596	UTILITY ASSISTANCE	74.03	kclevenger
537	031541	COM ED	2018-373	UTILITY ASSISTANCE W	11/20/18	89020006596	UTILITY ASSISTANCE	100.00	kclevenger
538	031541	COM ED	2018-374	UTILITY ASSISTANCE M	11/20/18	89020006596	UTILITY ASSISTANCE	89.28	kclevenger
539	031541	COM ED	2018-376	UTILITY ASSISTANCE P	11/20/18	89020006596	UTILITY ASSISTANCE	28.33	kclevenger
540	031541	COM ED	2018-377	UTILITY ASSISTANCE W	11/20/18	89020006596	UTILITY ASSISTANCE	100.00	kclevenger
541	031541	COM ED	2018-378	UTILITY ASSISTANCE O	11/20/18	89020006596	UTILITY ASSISTANCE	96.98	kclevenger
542	031541	COM ED	2018-379	UTILITY ASSISTANCE L	11/20/18	89020006596	UTILITY ASSISTANCE	50.60	kclevenger
543	140926	NICOR GAS	2018-371	UTILITY ASSISTANCE M	11/20/18	89020006596	UTILITY ASSISTANCE	29.41	kclevenger
544	140926	NICOR GAS	2018-380	UTILITY ASSISTANCE L	11/20/18	89020006596	UTILITY ASSISTANCE	22.94	kclevenger
							750.23*		
545	060323	FIRST NATIONAL BANK OMAHA	2018-383	VETERANS DAY PINS	11/20/18	89020006970	ADVERTISING	129.90	kclevenger
							129.90*		
546	060323	FIRST NATIONAL BANK OMAHA	2018-381	VACKC VEHICLES IPASS	11/20/18	89020006974	VACKC VEHICLES - I-PASS	100.00	kclevenger
							100.00*		

Vendor#	Name	Invoice #	Description	Date	Budget #	Account Description	Dist	Amount	
547 160189	PARADISE CAR WASH	2018-368	VACKC VEHICLE MAINTEN	11/20/18	89020006975	VACKC VEHICLES - MAINTENA		21.00 21.00*	kelevenger
Total VETERANS ASSISTANCE COMMISSIO								6,070.09*	
FP BOND PROCEEDS 2007									
548 010162	A&B EXTERIORS, LLC.	HARRIS SHELTER	HARRIS SHELTERS 1 &4	11/20/18	95020006850	PROJECT FUND EXPENSES		8,057.83 ***	
549 160985	PIZZO & ASSOC, LTD	118134-F-FPK	HOOVER CLEARING PROJ	11/20/18	95020006850	PROJECT FUND EXPENSES		1,520.00	bantrim
550 190620	SERVICE EXPERTS	EL EQUIP	EL-A/C UNIT REPLACEM	11/20/18	95020006850	PROJECT FUND EXPENSES		7,245.00 16,822.83*	bantrim
Total FP BOND PROCEEDS 2007								16,822.83*	
GRAND TOTAL								2,484,377.35**	

Vendor#	Name	Invoice #	Description	Date	Budget #	Account Description	Dist Amount
ELECTION COSTS							
1	011427	MARLENE M ANDOE	185094	Election Judge Compensati	11/12/18	01020076152	ELECTION JUDGES PER DIEM 150.00
2	012210	ALMA AVALOS	185381	Election Judge Compensati	11/12/18	01020076152	ELECTION JUDGES PER DIEM 170.00
3	020104	DONNA BAILEY	185189	Election Judge Compensati	11/12/18	01020076152	ELECTION JUDGES PER DIEM 150.00
4	020123	KATHRYN E. BAHR	185217	Election Judge Compensati	11/12/18	01020076152	ELECTION JUDGES PER DIEM 150.00
5	020127	RANNALT G. BAHR	185218	Election Judge Compensati	11/12/18	01020076152	ELECTION JUDGES PER DIEM 150.00
6	020143	CHERYL R. BARBER	185082	Election Judge Compensati	11/12/18	01020076152	ELECTION JUDGES PER DIEM 150.00
7	020199	ROBERT R. BAZAN	185179	Election Judge Compensati	11/12/18	01020076152	ELECTION JUDGES PER DIEM 150.00
8	020217	KIMBERLY BATTCHER	185416	Election Judge Compensati	11/12/18	01020076152	ELECTION JUDGES PER DIEM 140.00
9	020220	ANDREW BATTCHER	185415	Election Judge Compensati	11/12/18	01020076152	ELECTION JUDGES PER DIEM 150.00
10	020225	JANICE L. BAUM	185219	Election Judge Compensati	11/12/18	01020076152	ELECTION JUDGES PER DIEM 150.00
11	020521	KAREN M. BELL	185115	Election Judge Compensati	11/12/18	01020076152	ELECTION JUDGES PER DIEM 150.00
12	020531	JACQUES K. BENSON	185318	Election Judge Compensati	11/12/18	01020076152	ELECTION JUDGES PER DIEM 140.00
13	020546	MARIANN T BENDA	185262	Election Judge Compensati	11/12/18	01020076152	ELECTION JUDGES PER DIEM 150.00
14	020553	JULIE BENNETT	185184	Election Judge Compensati	11/12/18	01020076152	ELECTION JUDGES PER DIEM 150.00
15	020564	LEROY C. BENSON	185204	Election Judge Compensati	11/12/18	01020076152	ELECTION JUDGES PER DIEM 150.00
16	020584	MARILYN A. BERMES	185274	Election Judge Compensati	11/12/18	01020076152	ELECTION JUDGES PER DIEM 150.00
17	020587	JAMES W. BERRY, JR.	185244	Election Judge Compensati	11/12/18	01020076152	ELECTION JUDGES PER DIEM 150.00
18	020948	REY E. BLANCO	185125	Election Judge Compensati	11/12/18	01020076152	ELECTION JUDGES PER DIEM 150.00
19	021506	JOY C. BOWLING	185319	Election Judge Compensati	11/12/18	01020076152	ELECTION JUDGES PER DIEM 150.00
20	021603	BRUCE J. BOWERS	185104	Election Judge Compensati	11/12/18	01020076152	ELECTION JUDGES PER DIEM 150.00
21	021640	ANN MARIE BORS	185391	Election Judge Compensati	11/12/18	01020076152	ELECTION JUDGES PER DIEM 150.00
22	021750	JAMES E. BRADLEY	185338	Election Judge Compensati	11/12/18	01020076152	ELECTION JUDGES PER DIEM 150.00
23	021841	MARY PAT BRETHAUER	185370	Election Judge Compensati	11/12/18	01020076152	ELECTION JUDGES PER DIEM 150.00
24	021854	ANTHONY L. BRIDGES	185323	Election Judge Compensati	11/12/18	01020076152	ELECTION JUDGES PER DIEM 150.00
25	021875	KIMBERLY S. BRIGGS-OTT	185419	Election Judge Compensati	11/12/18	01020076152	ELECTION JUDGES PER DIEM 150.00
26	021924	KATHLEEN E. BROOKS	185226	Election Judge Compensati	11/12/18	01020076152	ELECTION JUDGES PER DIEM 150.00
27	021945	PATRICIA A BRUMMEL	185382	Election Judge Compensati	11/12/18	01020076152	ELECTION JUDGES PER DIEM 150.00
28	021970	MICHAEL R BRUNS	185105	Election Judge Compensati	11/12/18	01020076152	ELECTION JUDGES PER DIEM 150.00
29	021990	KATHLEEN L BUCARO	185135	Election Judge Compensati	11/12/18	01020076152	ELECTION JUDGES PER DIEM 150.00
30	022140	KAROL J BUNDY	185403	Election Judge Compensati	11/12/18	01020076152	ELECTION JUDGES PER DIEM 150.00
31	022144	DEAN A. BUNDY	185402	Election Judge Compensati	11/12/18	01020076152	ELECTION JUDGES PER DIEM 150.00
32	022172	JOSEPH L. BURKE	185324	Election Judge Compensati	11/12/18	01020076152	ELECTION JUDGES PER DIEM 150.00
33	022558	HILLARD BRYANT	185084	Election Judge Compensati	11/12/18	01020076152	ELECTION JUDGES PER DIEM 150.00
34	022559	JOHANNA L. BYRAM	185374	Election Judge Compensati	11/12/18	01020076152	ELECTION JUDGES PER DIEM 150.00
35	022561	MICHAEL J. BYRNE	185190	Election Judge Compensati	11/12/18	01020076152	ELECTION JUDGES PER DIEM 150.00
36	030194	CHRISTINE M. CAVANAUGH	185171	Election Judge Compensati	11/12/18	01020076152	ELECTION JUDGES PER DIEM 150.00
37	030806	DOLLY A. CHAREST	185250	Election Judge Compensati	11/12/18	01020076152	ELECTION JUDGES PER DIEM 140.00
38	030830	BARBARA A. CHRIS	185222	Election Judge Compensati	11/12/18	01020076152	ELECTION JUDGES PER DIEM 150.00
39	030853	DIANE L. CHUDZIK	185404	Election Judge Compensati	11/12/18	01020076152	ELECTION JUDGES PER DIEM 150.00
40	030861	PAUL V. CHRISTENSEN	185263	Election Judge Compensati	11/12/18	01020076152	ELECTION JUDGES PER DIEM 150.00
41	031104	BRIAN CLASON	185089	Election Judge Compensati	11/12/18	01020076152	ELECTION JUDGES PER DIEM 150.00
42	031111	DEBRA L. F. CLASON	185087	Election Judge Compensati	11/12/18	01020076152	ELECTION JUDGES PER DIEM 150.00
43	031130	KATHERINE CLARKE	185209	Election Judge Compensati	11/12/18	01020076152	ELECTION JUDGES PER DIEM 150.00
44	031220	DAVID CLINE	185405	Election Judge Compensati	11/12/18	01020076152	ELECTION JUDGES PER DIEM 150.00
45	031430	THOMAS R. COLLINS	185346	Election Judge Compensati	11/12/18	01020076152	ELECTION JUDGES PER DIEM 150.00
46	031480	DURAH J. CONNELL	185386	Election Judge Compensati	11/12/18	01020076152	ELECTION JUDGES PER DIEM 150.00
47	031540	PATRICIA A. COMER	185107	Election Judge Compensati	11/12/18	01020076152	ELECTION JUDGES PER DIEM 150.00
48	031550	STEPHEN J. CORCORAN	185387	Election Judge Compensati	11/12/18	01020076152	ELECTION JUDGES PER DIEM 150.00

Vendor#	Name	Invoice #	Description	Date	Budget #	Account Description	Dist Amount	
49	031568	RAYMOND E COOLEY	185259	Election Judge Compensati	11/12/18	01020076152	ELECTION JUDGES PER DIEM	150.00
50	031570	MARY CORDUAN	185409	Election Judge Compensati	11/12/18	01020076152	ELECTION JUDGES PER DIEM	150.00
51	031576	PETER P. CORDUAN	185410	Election Judge Compensati	11/12/18	01020076152	ELECTION JUDGES PER DIEM	170.00
52	031578	CYNTHIA COOLEY	185258	Election Judge Compensati	11/12/18	01020076152	ELECTION JUDGES PER DIEM	150.00
53	031639	JEFFERY COX	185425	Election Judge Compensati	11/12/18	01020076152	ELECTION JUDGES PER DIEM	170.00
54	031770	KAREN CRAIG	185213	Election Judge Compensati	11/12/18	01020076152	ELECTION JUDGES PER DIEM	150.00
55	031830	CAROLE J CRUM	185295	Election Judge Compensati	11/12/18	01020076152	ELECTION JUDGES PER DIEM	150.00
56	040191	SCOTT MICHAEL DAVIS	185156	Election Judge Compensati	11/12/18	01020076152	ELECTION JUDGES PER DIEM	150.00
57	040192	JUDITH E. DAVIS	185430	Election Judge Compensati	11/12/18	01020076152	ELECTION JUDGES PER DIEM	150.00
58	040205	GLENDA I. DAZZO	185227	Election Judge Compensati	11/12/18	01020076152	ELECTION JUDGES PER DIEM	150.00
59	040302	TERRY A. DEARBORN	185120	Election Judge Compensati	11/12/18	01020076152	ELECTION JUDGES PER DIEM	150.00
60	040425	LINDA DEBOLT	185095	Election Judge Compensati	11/12/18	01020076152	ELECTION JUDGES PER DIEM	150.00
61	040533	ANNE KRISTINE DELANGE	185441	Election Judge Compensati	11/12/18	01020076152	ELECTION JUDGES PER DIEM	150.00
62	040850	BRIAN DINER	185351	Election Judge Compensati	11/12/18	01020076152	ELECTION JUDGES PER DIEM	150.00
63	041250	WILLIAM A. DOBRAN JR	185240	Election Judge Compensati	11/12/18	01020076152	ELECTION JUDGES PER DIEM	150.00
64	041512	DAVID A. DONKERS	185166	Election Judge Compensati	11/12/18	01020076152	ELECTION JUDGES PER DIEM	150.00
65	041514	ANITA M. DONKERS	185165	Election Judge Compensati	11/12/18	01020076152	ELECTION JUDGES PER DIEM	170.00
66	041650	JOSEPH A. DOYLE	185453	Election Judge Compensati	11/12/18	01020076152	ELECTION JUDGES PER DIEM	150.00
67	042200	CAROL A. DZIEKANOWSKI	185129	Election Judge Compensati	11/12/18	01020076152	ELECTION JUDGES PER DIEM	150.00
68	050776	DESIREE D.EDWARDS	185308	Election Judge Compensati	11/12/18	01020076152	ELECTION JUDGES PER DIEM	150.00
69	051453	PATRICIA A. ENGELHARDT	185378	Election Judge Compensati	11/12/18	01020076152	ELECTION JUDGES PER DIEM	150.00
70	060157	JOHN J. FAYFAR	185228	Election Judge Compensati	11/12/18	01020076152	ELECTION JUDGES PER DIEM	150.00
71	060321	SAMUEL J. FIGOLA	185232	Election Judge Compensati	11/12/18	01020076152	ELECTION JUDGES PER DIEM	170.00
72	060350	NANCY JO FINNERTY	185384	Election Judge Compensati	11/12/18	01020076152	ELECTION JUDGES PER DIEM	150.00
73	060504	RUSSELL J. FERGUSON	185394	Election Judge Compensati	11/12/18	01020076152	ELECTION JUDGES PER DIEM	150.00
74	061750	NANCY JO FRANZ	185097	Election Judge Compensati	11/12/18	01020076152	ELECTION JUDGES PER DIEM	150.00
75	061890	RICKY A FRY	185264	Election Judge Compensati	11/12/18	01020076152	ELECTION JUDGES PER DIEM	150.00
76	070136	BRIANNA GALLAGHER	185339	Election Judge Compensati	11/12/18	01020076152	ELECTION JUDGES PER DIEM	150.00
77	070195	SHAREN L. GAVIN	185080	Election Judge Compensati	11/12/18	01020076152	ELECTION JUDGES PER DIEM	150.00
78	071587	MATTHEW GORNEY	185255	Election Judge Compensati	11/12/18	01020076152	ELECTION JUDGES PER DIEM	170.00
79	080102	ALEXANDER R. HALLENBECK	185110	Election Judge Compensati	11/12/18	01020076152	ELECTION JUDGES PER DIEM	150.00
80	080135	CHRISTINE P. HAMPTON	185248	Election Judge Compensati	11/12/18	01020076152	ELECTION JUDGES PER DIEM	150.00
81	080193	LINDA L HARMON	185142	Election Judge Compensati	11/12/18	01020076152	ELECTION JUDGES PER DIEM	150.00
82	080209	JAMES A. HAY JR	185090	Election Judge Compensati	11/12/18	01020076152	ELECTION JUDGES PER DIEM	150.00
83	080290	LINDA S. HASSELBRING	185396	Election Judge Compensati	11/12/18	01020076152	ELECTION JUDGES PER DIEM	150.00
84	080903	ALICE F. HICKMAN	185141	Election Judge Compensati	11/12/18	01020076152	ELECTION JUDGES PER DIEM	150.00
85	080937	MARY ANN HISLOP	185220	Election Judge Compensati	11/12/18	01020076152	ELECTION JUDGES PER DIEM	150.00
86	081227	BARBARA E. HOGAN	185397	Election Judge Compensati	11/12/18	01020076152	ELECTION JUDGES PER DIEM	150.00
87	081552	JOHN HORWATH JR.	185153	Election Judge Compensati	11/12/18	01020076152	ELECTION JUDGES PER DIEM	150.00
88	081555	CHRISTIAN A. HORWATH	185152	Election Judge Compensati	11/12/18	01020076152	ELECTION JUDGES PER DIEM	150.00
89	081582	STACEY R. HOSPES	185325	Election Judge Compensati	11/12/18	01020076152	ELECTION JUDGES PER DIEM	150.00
90	081590	SHARON R. HUBER	185210	Election Judge Compensati	11/12/18	01020076152	ELECTION JUDGES PER DIEM	150.00
91	082125	CORA JANE HUGHES	185091	Election Judge Compensati	11/12/18	01020076152	ELECTION JUDGES PER DIEM	150.00
92	091338	ANGELA M. IMBROGNO	185348	Election Judge Compensati	11/12/18	01020076152	ELECTION JUDGES PER DIEM	150.00
93	100151	MICHAEL A. JAMES	185126	Election Judge Compensati	11/12/18	01020076152	ELECTION JUDGES PER DIEM	150.00
94	101296	THOMAS L. JOHANNESSEN SR	185302	Election Judge Compensati	11/12/18	01020076152	ELECTION JUDGES PER DIEM	150.00
95	101405	DOREEN L JOHNSON	185335	Election Judge Compensati	11/12/18	01020076152	ELECTION JUDGES PER DIEM	150.00
96	101409	JACQUELINE L. JOHNSON	185288	Election Judge Compensati	11/12/18	01020076152	ELECTION JUDGES PER DIEM	150.00
97	101522	KENT W JOHNSON	185215	Election Judge Compensati	11/12/18	01020076152	ELECTION JUDGES PER DIEM	150.00

Vendor#	Name	Invoice #	Description	Date	Budget #	Account Description	Dist Amount
98	101534	ROGER GLENN JOHNSTON	185420	Election Judge Compensati	11/12/18	01020076152	ELECTION JUDGES PER DIEM 150.00
99	101581	LORI J JORDAN	185279	Election Judge Compensati	11/12/18	01020076152	ELECTION JUDGES PER DIEM 150.00
100	102140	SHERRY G. JURSA	185326	Election Judge Compensati	11/12/18	01020076152	ELECTION JUDGES PER DIEM 150.00
101	110114	GERALD E. KAISER	185180	Election Judge Compensati	11/12/18	01020076152	ELECTION JUDGES PER DIEM 150.00
102	110171	RICHARD C. KAYER	185314	Election Judge Compensati	11/12/18	01020076152	ELECTION JUDGES PER DIEM 150.00
103	110330	AMY L. KELLY	185181	Election Judge Compensati	11/12/18	01020076152	ELECTION JUDGES PER DIEM 150.00
104	110946	MICHAEL J. KIMMEY JR	185085	Election Judge Compensati	11/12/18	01020076152	ELECTION JUDGES PER DIEM 150.00
105	111506	JAMES E. KOCK	185118	Election Judge Compensati	11/12/18	01020076152	ELECTION JUDGES PER DIEM 150.00
106	111512	LOIS M. KONICEK	185186	Election Judge Compensati	11/12/18	01020076152	ELECTION JUDGES PER DIEM 150.00
107	111521	THOMAS R. KOPACE	185327	Election Judge Compensati	11/12/18	01020076152	ELECTION JUDGES PER DIEM 150.00
108	120112	MARK A LA BEDZ SR.	185098	Election Judge Compensati	11/12/18	01020076152	ELECTION JUDGES PER DIEM 150.00
109	120138	JEANETTE LANDERS	185211	Election Judge Compensati	11/12/18	01020076152	ELECTION JUDGES PER DIEM 150.00
110	120153	BARBARA A. LANE	185148	Election Judge Compensati	11/12/18	01020076152	ELECTION JUDGES PER DIEM 150.00
111	120157	DANTEI T. LANE	185149	Election Judge Compensati	11/12/18	01020076152	ELECTION JUDGES PER DIEM 150.00
112	120235	DANA K. LARSON	185168	Election Judge Compensati	11/12/18	01020076152	ELECTION JUDGES PER DIEM 150.00
113	120390	BARBARA LECKBEE	185216	Election Judge Compensati	11/12/18	01020076152	ELECTION JUDGES PER DIEM 150.00
114	120570	MICHAEL E. LESLIE	185233	Election Judge Compensati	11/12/18	01020076152	ELECTION JUDGES PER DIEM 150.00
115	120710	EDWARD WEIL LICHTENSTEIN	185285	Election Judge Compensati	11/12/18	01020076152	ELECTION JUDGES PER DIEM 150.00
116	120960	PATRICIA A. LIPPOLD	185367	Election Judge Compensati	11/12/18	01020076152	ELECTION JUDGES PER DIEM 150.00
117	122130	EVA L. LUCKINBILL	185270	Election Judge Compensati	11/12/18	01020076152	ELECTION JUDGES PER DIEM 150.00
118	122140	MARGARET SMITH-LUBINSKI	185436	Election Judge Compensati	11/12/18	01020076152	ELECTION JUDGES PER DIEM 150.00
119	122151	CARIN LUGO	185427	Election Judge Compensati	11/12/18	01020076152	ELECTION JUDGES PER DIEM 175.00
120	130018	JUDITH M. MAECHTLE	185236	Election Judge Compensati	11/12/18	01020076152	ELECTION JUDGES PER DIEM 150.00
121	130075	ROBERT W. MADISON	185329	Election Judge Compensati	11/12/18	01020076152	ELECTION JUDGES PER DIEM 150.00
122	130120	BETTY MALONE	185431	Election Judge Compensati	11/12/18	01020076152	ELECTION JUDGES PER DIEM 150.00
123	130123	DEBRA M. MC DOUGLE	185320	Election Judge Compensati	11/12/18	01020076152	ELECTION JUDGES PER DIEM 150.00
124	130131	FERRY L. MAMON JR	185192	Election Judge Compensati	11/12/18	01020076152	ELECTION JUDGES PER DIEM 150.00
125	130133	PAUL H. MALOHN	185399	Election Judge Compensati	11/12/18	01020076152	ELECTION JUDGES PER DIEM 150.00
126	130137	CURTISEAN MAMON	185191	Election Judge Compensati	11/12/18	01020076152	ELECTION JUDGES PER DIEM 150.00
127	130138	JACQUELINE P. MCAFEE	185241	Election Judge Compensati	11/12/18	01020076152	ELECTION JUDGES PER DIEM 150.00
128	130195	THOMAS R. MARUNDE	185286	Election Judge Compensati	11/12/18	01020076152	ELECTION JUDGES PER DIEM 140.00
129	130245	JUDY C. MARSH	185247	Election Judge Compensati	11/12/18	01020076152	ELECTION JUDGES PER DIEM 150.00
130	130260	EDWARD MAHER III	185340	Election Judge Compensati	11/12/18	01020076152	ELECTION JUDGES PER DIEM 150.00
131	130304	JOAN L. MC EACHERN	185122	Election Judge Compensati	11/12/18	01020076152	ELECTION JUDGES PER DIEM 150.00
132	130332	MARY R MC CRACKEN	185379	Election Judge Compensati	11/12/18	01020076152	ELECTION JUDGES PER DIEM 150.00
133	130348	GERESE J. MC CURDY	185315	Election Judge Compensati	11/12/18	01020076152	ELECTION JUDGES PER DIEM 140.00
134	130953	FRANCINE E. MILLER	185445	Election Judge Compensati	11/12/18	01020076152	ELECTION JUDGES PER DIEM 150.00
135	130956	RONALD ROY MILLER	185446	Election Judge Compensati	11/12/18	01020076152	ELECTION JUDGES PER DIEM 150.00
136	131542	DIANA LYNN MORGANEGG	185119	Election Judge Compensati	11/12/18	01020076152	ELECTION JUDGES PER DIEM 150.00
137	131561	J. DONALD MORRIS	185400	Election Judge Compensati	11/12/18	01020076152	ELECTION JUDGES PER DIEM 150.00
138	131665	VIRGINIA K. MULLINER	185092	Election Judge Compensati	11/12/18	01020076152	ELECTION JUDGES PER DIEM 150.00
139	140097	BETTY GRACE NADEN	185401	Election Judge Compensati	11/12/18	01020076152	ELECTION JUDGES PER DIEM 150.00
140	140110	RICHARD A. NATHAN	185345	Election Judge Compensati	11/12/18	01020076152	ELECTION JUDGES PER DIEM 150.00
141	140516	NANCY K. NESS	185432	Election Judge Compensati	11/12/18	01020076152	ELECTION JUDGES PER DIEM 150.00
142	140565	JOHN F. NEVILLE JR.	185196	Election Judge Compensati	11/12/18	01020076152	ELECTION JUDGES PER DIEM 160.00
143	150915	VIRGIL G OSTRENG	185265	Election Judge Compensati	11/12/18	01020076152	ELECTION JUDGES PER DIEM 170.00
144	151211	LEE ANN OLSON	185297	Election Judge Compensati	11/12/18	01020076152	ELECTION JUDGES PER DIEM 150.00
145	152075	CRAIG OTT JR.	185417	Election Judge Compensati	11/12/18	01020076152	ELECTION JUDGES PER DIEM 150.00
146	160187	JUDY PATTERSON	185407	Election Judge Compensati	11/12/18	01020076152	ELECTION JUDGES PER DIEM 150.00

Vendor#	Name	Invoice #	Description	Date	Budget #	Account Description	Dist Amount	
147	160235	DASHA PATES	185237	Election Judge Compensati	11/12/18	01020076152	ELECTION JUDGES PER DIEM	170.00
148	160562	PARALEE M. PERKINS	185197	Election Judge Compensati	11/12/18	01020076152	ELECTION JUDGES PER DIEM	150.00
149	160839	KAY PHILLIPS	185131	Election Judge Compensati	11/12/18	01020076152	ELECTION JUDGES PER DIEM	150.00
150	160860	BRADLEY W. PHILLIPS	185130	Election Judge Compensati	11/12/18	01020076152	ELECTION JUDGES PER DIEM	150.00
151	161573	ELIZABETH A. POPOVICH	185182	Election Judge Compensati	11/12/18	01020076152	ELECTION JUDGES PER DIEM	150.00
152	161740	MICHELLE R. PRENTICE	185123	Election Judge Compensati	11/12/18	01020076152	ELECTION JUDGES PER DIEM	150.00
153	161822	KYLE ALLEN PRICE	185143	Election Judge Compensati	11/12/18	01020076152	ELECTION JUDGES PER DIEM	20.00
154	180111	CANDACE A. RADY	185093	Election Judge Compensati	11/12/18	01020076152	ELECTION JUDGES PER DIEM	150.00
155	180118	DOROTHY RAGSDALE	185221	Election Judge Compensati	11/12/18	01020076152	ELECTION JUDGES PER DIEM	150.00
156	180159	GLENN A RAKOSNIK	185183	Election Judge Compensati	11/12/18	01020076152	ELECTION JUDGES PER DIEM	150.00
157	180167	RUTH ANN RADER	185137	Election Judge Compensati	11/12/18	01020076152	ELECTION JUDGES PER DIEM	170.00
158	180425	SHARON MARIE REDWANZJOHNSON	185223	Election Judge Compensati	11/12/18	01020076152	ELECTION JUDGES PER DIEM	150.00
159	180430	GERGORY M. REDFERN	185272	Election Judge Compensati	11/12/18	01020076152	ELECTION JUDGES PER DIEM	150.00
160	180527	CANDACE J. REINERT	185083	Election Judge Compensati	11/12/18	01020076152	ELECTION JUDGES PER DIEM	150.00
161	180581	RICHARD R RENIK SR.	185187	Election Judge Compensati	11/12/18	01020076152	ELECTION JUDGES PER DIEM	150.00
162	180918	KATHLEEN C. RICHMOND	185088	Election Judge Compensati	11/12/18	01020076152	ELECTION JUDGES PER DIEM	150.00
163	180933	LOUISE M. RIEDL	185155	Election Judge Compensati	11/12/18	01020076152	ELECTION JUDGES PER DIEM	150.00
164	180946	GILDARDO E. RIOS	185188	Election Judge Compensati	11/12/18	01020076152	ELECTION JUDGES PER DIEM	150.00
165	181580	BETH A. ROUSSEAU	185086	Election Judge Compensati	11/12/18	01020076152	ELECTION JUDGES PER DIEM	150.00
166	181900	GREGORY J. ROZBORSKI	185100	Election Judge Compensati	11/12/18	01020076152	ELECTION JUDGES PER DIEM	150.00
167	181915	BRENDA J. ROZBORSKI	185099	Election Judge Compensati	11/12/18	01020076152	ELECTION JUDGES PER DIEM	150.00
168	182130	JENNIFER J. RUFF	185133	Election Judge Compensati	11/12/18	01020076152	ELECTION JUDGES PER DIEM	150.00
169	190340	NEIL G. SCHILLING	185201	Election Judge Compensati	11/12/18	01020076152	ELECTION JUDGES PER DIEM	150.00
170	190400	GEORGIA G SCOGGIN	185134	Election Judge Compensati	11/12/18	01020076152	ELECTION JUDGES PER DIEM	150.00
171	190460	DENNIS L. SCHOLTZ	185112	Election Judge Compensati	11/12/18	01020076152	ELECTION JUDGES PER DIEM	150.00
172	190465	KATHLEEN M. SCHOLTZ	185113	Election Judge Compensati	11/12/18	01020076152	ELECTION JUDGES PER DIEM	150.00
173	190518	DONNA J. SEBBY	185138	Election Judge Compensati	11/12/18	01020076152	ELECTION JUDGES PER DIEM	150.00
174	191530	VIRGINIA L. SNODGRASS	185202	Election Judge Compensati	11/12/18	01020076152	ELECTION JUDGES PER DIEM	170.00
175	191607	JEFFREY ALAN SPANG	185373	Election Judge Compensati	11/12/18	01020076152	ELECTION JUDGES PER DIEM	150.00
176	191941	SHIRLEY I. STALLMANN	185234	Election Judge Compensati	11/12/18	01020076152	ELECTION JUDGES PER DIEM	150.00
177	191954	DANIEL K. STAPLEY	185422	Election Judge Compensati	11/12/18	01020076152	ELECTION JUDGES PER DIEM	150.00
178	192045	VIRGINIA A STIBBE	185377	Election Judge Compensati	11/12/18	01020076152	ELECTION JUDGES PER DIEM	150.00
179	192085	REBECCA E. STRYKOWSKI	185145	Election Judge Compensati	11/12/18	01020076152	ELECTION JUDGES PER DIEM	150.00
180	192102	CYNTHIA STRYKOWSKI	185144	Election Judge Compensati	11/12/18	01020076152	ELECTION JUDGES PER DIEM	150.00
181	200849	LAMONT E. THOMAS	185298	Election Judge Compensati	11/12/18	01020076152	ELECTION JUDGES PER DIEM	140.00
182	200915	SHAWN L. TORRES	185447	Election Judge Compensati	11/12/18	01020076152	ELECTION JUDGES PER DIEM	150.00
183	202180	SHEILA A TROST	185448	Election Judge Compensati	11/12/18	01020076152	ELECTION JUDGES PER DIEM	150.00
184	211750	BRENT E. URTON	185438	Election Judge Compensati	11/12/18	01020076152	ELECTION JUDGES PER DIEM	150.00
185	211755	SHEILA MARIE URTON	185439	Election Judge Compensati	11/12/18	01020076152	ELECTION JUDGES PER DIEM	150.00
186	211820	DEBRA L. UPSHAW	185451	Election Judge Compensati	11/12/18	01020076152	ELECTION JUDGES PER DIEM	150.00
187	211826	TYRONNE UPSHAW	185452	Election Judge Compensati	11/12/18	01020076152	ELECTION JUDGES PER DIEM	150.00
188	230116	MARK E. WARREN	185455	Election Judge Compensati	11/12/18	01020076152	ELECTION JUDGES PER DIEM	150.00
189	230153	JAMES E. WARD	185395	Election Judge Compensati	11/12/18	01020076152	ELECTION JUDGES PER DIEM	150.00
190	230191	BARBARA ANN WEBER	185212	Election Judge Compensati	11/12/18	01020076152	ELECTION JUDGES PER DIEM	150.00
191	230835	DANA W WHITE	185368	Election Judge Compensati	11/12/18	01020076152	ELECTION JUDGES PER DIEM	150.00
192	230837	ROSE ANN M. WHITESIDE	185170	Election Judge Compensati	11/12/18	01020076152	ELECTION JUDGES PER DIEM	150.00
193	230838	LINDA L WHITE	185257	Election Judge Compensati	11/12/18	01020076152	ELECTION JUDGES PER DIEM	150.00
194	230847	SHARON K. WHITE	185369	Election Judge Compensati	11/12/18	01020076152	ELECTION JUDGES PER DIEM	150.00
195	230983	MARY L. WOLF	185230	Election Judge Compensati	11/12/18	01020076152	ELECTION JUDGES PER DIEM	150.00

Vendor#	Name	Invoice #	Description	Date	Budget #	Account Description	Dist	Amount
196	230997	SUSAN L. WINBORNE	185316	Election Judge Compensati	11/12/18	01020076152	ELECTION JUDGES PER DIEM	170.00
197	231355	DAVID FOREST WOOTEN	185124	Election Judge Compensati	11/12/18	01020076152	ELECTION JUDGES PER DIEM	150.00
198	231370	STANLEY C. WOOLLEY	185103	Election Judge Compensati	11/12/18	01020076152	ELECTION JUDGES PER DIEM	150.00
199	251934	RAMONA B. YOUNG	185117	Election Judge Compensati	11/12/18	01020076152	ELECTION JUDGES PER DIEM	150.00
200	261427	SARA P. SMITH	185433	Election Judge Compensati	11/12/18	01020076152	ELECTION JUDGES PER DIEM	150.00
201	263794	ROBERT HALLENBECK	185111	Election Judge Compensati	11/12/18	01020076152	ELECTION JUDGES PER DIEM	150.00
202	263795	VIORICA RATTIU	185132	Election Judge Compensati	11/12/18	01020076152	ELECTION JUDGES PER DIEM	140.00
203	263797	SUSAN HART	185140	Election Judge Compensati	11/12/18	01020076152	ELECTION JUDGES PER DIEM	150.00
204	263804	JOHN E KOKES	185167	Election Judge Compensati	11/12/18	01020076152	ELECTION JUDGES PER DIEM	150.00
205	263805	RAMELIA M LOWE	185154	Election Judge Compensati	11/12/18	01020076152	ELECTION JUDGES PER DIEM	170.00
206	263810	SHARON A WHITE KOS	185208	Election Judge Compensati	11/12/18	01020076152	ELECTION JUDGES PER DIEM	150.00
207	263814	JAMES W DAVIDSON	185231	Election Judge Compensati	11/12/18	01020076152	ELECTION JUDGES PER DIEM	150.00
208	263815	CAROLYN J BRADLEY	185337	Election Judge Compensati	11/12/18	01020076152	ELECTION JUDGES PER DIEM	150.00
209	263818	JANICE M FERGUSON	185393	Election Judge Compensati	11/12/18	01020076152	ELECTION JUDGES PER DIEM	150.00
210	263819	ROGER L BLEDSOE	185408	Election Judge Compensati	11/12/18	01020076152	ELECTION JUDGES PER DIEM	150.00
211	263820	DIANE M STAPLEY	185423	Election Judge Compensati	11/12/18	01020076152	ELECTION JUDGES PER DIEM	150.00
212	265947	DORIS FOWLER	185101	Election Judge Compensati	11/12/18	01020076152	ELECTION JUDGES PER DIEM	150.00
213	265948	DEBRA STYMACKS	185102	Election Judge Compensati	11/12/18	01020076152	ELECTION JUDGES PER DIEM	150.00
214	265950	LUCAS WOODS	185146	Election Judge Compensati	11/12/18	01020076152	ELECTION JUDGES PER DIEM	150.00
215	265951	KENNETH FUCHS	185106	Election Judge Compensati	11/12/18	01020076152	ELECTION JUDGES PER DIEM	140.00
216	265952	THOMAS LENNON	185121	Election Judge Compensati	11/12/18	01020076152	ELECTION JUDGES PER DIEM	150.00
217	265973	LORILYN HERNANDEZ	185162	Election Judge Compensati	11/12/18	01020076152	ELECTION JUDGES PER DIEM	140.00
218	265974	CAROL REUTER	185169	Election Judge Compensati	11/12/18	01020076152	ELECTION JUDGES PER DIEM	150.00
219	265980	KELLY FITZPATRICK	185174	Election Judge Compensati	11/12/18	01020076152	ELECTION JUDGES PER DIEM	150.00
220	265984	KATHERINE EDINGER	185185	Election Judge Compensati	11/12/18	01020076152	ELECTION JUDGES PER DIEM	150.00
221	265985	WILLIAM T. WIADUCH	185193	Election Judge Compensati	11/12/18	01020076152	ELECTION JUDGES PER DIEM	150.00
222	265987	JUDITH LUYTJES	185194	Election Judge Compensati	11/12/18	01020076152	ELECTION JUDGES PER DIEM	150.00
223	265988	LARRY LUYTJES	185195	Election Judge Compensati	11/12/18	01020076152	ELECTION JUDGES PER DIEM	150.00
224	265992	GAIL DUDLICEK	185206	Election Judge Compensati	11/12/18	01020076152	ELECTION JUDGES PER DIEM	150.00
225	265993	SCOTT DUDLICEK	185207	Election Judge Compensati	11/12/18	01020076152	ELECTION JUDGES PER DIEM	150.00
226	266002	LINDA RAY	185266	Election Judge Compensati	11/12/18	01020076152	ELECTION JUDGES PER DIEM	150.00
227	266006	ERLINDA COAKES	185245	Election Judge Compensati	11/12/18	01020076152	ELECTION JUDGES PER DIEM	150.00
228	266007	NINA HEERMANN	185246	Election Judge Compensati	11/12/18	01020076152	ELECTION JUDGES PER DIEM	140.00
229	266009	ROBERT MCAFEE	185242	Election Judge Compensati	11/12/18	01020076152	ELECTION JUDGES PER DIEM	140.00
230	266012	MICHAEL JANIS	185199	Election Judge Compensati	11/12/18	01020076152	ELECTION JUDGES PER DIEM	150.00
231	266015	BRUCE MAYHUGH	185229	Election Judge Compensati	11/12/18	01020076152	ELECTION JUDGES PER DIEM	140.00
232	266017	GIRISH RAVAL	185271	Election Judge Compensati	11/12/18	01020076152	ELECTION JUDGES PER DIEM	150.00
233	266021	BRENDA GOODWIN	185267	Election Judge Compensati	11/12/18	01020076152	ELECTION JUDGES PER DIEM	140.00
234	266022	HARVEY GOODWIN	185268	Election Judge Compensati	11/12/18	01020076152	ELECTION JUDGES PER DIEM	140.00
235	266023	MARIA GWYNNE	185276	Election Judge Compensati	11/12/18	01020076152	ELECTION JUDGES PER DIEM	160.00
236	266033	JILL MARTER	185280	Election Judge Compensati	11/12/18	01020076152	ELECTION JUDGES PER DIEM	150.00
237	266043	MARK CRAIG	185214	Election Judge Compensati	11/12/18	01020076152	ELECTION JUDGES PER DIEM	150.00
238	266045	TIMOTHY RILEY	185224	Election Judge Compensati	11/12/18	01020076152	ELECTION JUDGES PER DIEM	140.00
239	266062	NANCY LARSON	185389	Election Judge Compensati	11/12/18	01020076152	ELECTION JUDGES PER DIEM	150.00
240	266064	JUDITH KOESTER	185398	Election Judge Compensati	11/12/18	01020076152	ELECTION JUDGES PER DIEM	150.00
241	266067	SUSAN FERGERSTROM	185392	Election Judge Compensati	11/12/18	01020076152	ELECTION JUDGES PER DIEM	150.00
242	266071	SUSANNA CORDUAN	185411	Election Judge Compensati	11/12/18	01020076152	ELECTION JUDGES PER DIEM	150.00
243	266073	MARK TOLEFREE	185414	Election Judge Compensati	11/12/18	01020076152	ELECTION JUDGES PER DIEM	150.00
244	266080	JEAN FLETCHER	185435	Election Judge Compensati	11/12/18	01020076152	ELECTION JUDGES PER DIEM	150.00

Vendor#	Name	Invoice #	Description	Date	Budget #	Account Description	Dist Amount	
245	267986	RACHEL TESTIN	185444	Election Judge Compensati	11/12/18	01020076152	ELECTION JUDGES PER DIEM	150.00
246	268477	CATHERINE RAMIREZ	185081	Election Judge Compensati	11/12/18	01020076152	ELECTION JUDGES PER DIEM	150.00
247	268478	RANDAL HUTCHISON	185096	Election Judge Compensati	11/12/18	01020076152	ELECTION JUDGES PER DIEM	170.00
248	268479	VICTORIA CRAWFORD	185108	Election Judge Compensati	11/12/18	01020076152	ELECTION JUDGES PER DIEM	150.00
249	268480	MYRIAH GARCIA	185109	Election Judge Compensati	11/12/18	01020076152	ELECTION JUDGES PER DIEM	150.00
250	268481	DEBERA YAMAMOTO	185114	Election Judge Compensati	11/12/18	01020076152	ELECTION JUDGES PER DIEM	150.00
251	268482	MADISON WOODS	185116	Election Judge Compensati	11/12/18	01020076152	ELECTION JUDGES PER DIEM	170.00
252	268483	DENEEN TURLEY	185127	Election Judge Compensati	11/12/18	01020076152	ELECTION JUDGES PER DIEM	170.00
253	268484	CYNTHIA WADE	185128	Election Judge Compensati	11/12/18	01020076152	ELECTION JUDGES PER DIEM	170.00
254	268485	CATHERINE O CONNOR	185136	Election Judge Compensati	11/12/18	01020076152	ELECTION JUDGES PER DIEM	150.00
255	268486	EMERSON DEKTER	185139	Election Judge Compensati	11/12/18	01020076152	ELECTION JUDGES PER DIEM	170.00
256	268487	JACKIE CARRILLO	185147	Election Judge Compensati	11/12/18	01020076152	ELECTION JUDGES PER DIEM	150.00
257	268488	REBECCA MONREAN	185150	Election Judge Compensati	11/12/18	01020076152	ELECTION JUDGES PER DIEM	150.00
258	268489	LEAH BERG	185151	Election Judge Compensati	11/12/18	01020076152	ELECTION JUDGES PER DIEM	150.00
259	268490	ZOE DOMARK	185157	Election Judge Compensati	11/12/18	01020076152	ELECTION JUDGES PER DIEM	150.00
260	268491	VALERIE GARCIA	185158	Election Judge Compensati	11/12/18	01020076152	ELECTION JUDGES PER DIEM	170.00
261	268492	BENJAMIN THOLEN	185159	Election Judge Compensati	11/12/18	01020076152	ELECTION JUDGES PER DIEM	150.00
262	268493	YARILIZ AGUADO	185160	Election Judge Compensati	11/12/18	01020076152	ELECTION JUDGES PER DIEM	170.00
263	268494	RITHVIK AKULA	185161	Election Judge Compensati	11/12/18	01020076152	ELECTION JUDGES PER DIEM	170.00
264	268495	SIDDHARTH KETHA	185163	Election Judge Compensati	11/12/18	01020076152	ELECTION JUDGES PER DIEM	150.00
265	268496	CRISTIAN RAICES	185164	Election Judge Compensati	11/12/18	01020076152	ELECTION JUDGES PER DIEM	150.00
266	268497	SAM DELA ROSA	185172	Election Judge Compensati	11/12/18	01020076152	ELECTION JUDGES PER DIEM	170.00
267	268498	MADISON GRANDYS	185173	Election Judge Compensati	11/12/18	01020076152	ELECTION JUDGES PER DIEM	170.00
268	268499	ALLISON MORITZ	185175	Election Judge Compensati	11/12/18	01020076152	ELECTION JUDGES PER DIEM	170.00
269	268500	LAURA RICHTER	185176	Election Judge Compensati	11/12/18	01020076152	ELECTION JUDGES PER DIEM	170.00
270	268501	CHRISTIAN VERTHEIN	185177	Election Judge Compensati	11/12/18	01020076152	ELECTION JUDGES PER DIEM	170.00
271	268502	HANNA ZEINSTR	185178	Election Judge Compensati	11/12/18	01020076152	ELECTION JUDGES PER DIEM	170.00
272	268503	JORDAN RADLOFF	185198	Election Judge Compensati	11/12/18	01020076152	ELECTION JUDGES PER DIEM	150.00
273	268504	PATRICK KREMER	185200	Election Judge Compensati	11/12/18	01020076152	ELECTION JUDGES PER DIEM	140.00
274	268505	JEREMY ABRAHAM	185203	Election Judge Compensati	11/12/18	01020076152	ELECTION JUDGES PER DIEM	170.00
275	268506	JULIA DILLMAN	185205	Election Judge Compensati	11/12/18	01020076152	ELECTION JUDGES PER DIEM	170.00
276	268507	PHILLIP SALISBURY	185225	Election Judge Compensati	11/12/18	01020076152	ELECTION JUDGES PER DIEM	150.00
277	268508	ANGELIKA CABANG	185235	Election Judge Compensati	11/12/18	01020076152	ELECTION JUDGES PER DIEM	150.00
278	268509	SATOMI RADOSITS	185238	Election Judge Compensati	11/12/18	01020076152	ELECTION JUDGES PER DIEM	170.00
279	268510	MARTHA CONOVER	185239	Election Judge Compensati	11/12/18	01020076152	ELECTION JUDGES PER DIEM	150.00
280	268511	SHANE NELSON	185243	Election Judge Compensati	11/12/18	01020076152	ELECTION JUDGES PER DIEM	150.00
281	268512	HISHAM ABDULBARI	185249	Election Judge Compensati	11/12/18	01020076152	ELECTION JUDGES PER DIEM	170.00
282	268513	SAMANTHA PICCIONE	185251	Election Judge Compensati	11/12/18	01020076152	ELECTION JUDGES PER DIEM	170.00
283	268514	ANH TRUONG	185252	Election Judge Compensati	11/12/18	01020076152	ELECTION JUDGES PER DIEM	150.00
284	268515	VIGNESH VAKATI	185253	Election Judge Compensati	11/12/18	01020076152	ELECTION JUDGES PER DIEM	150.00
285	268516	PARKER ABRELL	185254	Election Judge Compensati	11/12/18	01020076152	ELECTION JUDGES PER DIEM	150.00
286	268517	MARIBETH SURMA	185256	Election Judge Compensati	11/12/18	01020076152	ELECTION JUDGES PER DIEM	170.00
287	268518	ALYSSA CORRAL	185260	Election Judge Compensati	11/12/18	01020076152	ELECTION JUDGES PER DIEM	170.00
288	268519	EMMA SIGMOR	185261	Election Judge Compensati	11/12/18	01020076152	ELECTION JUDGES PER DIEM	150.00
289	268520	SUMMER LUBER	185269	Election Judge Compensati	11/12/18	01020076152	ELECTION JUDGES PER DIEM	140.00
290	268521	VIKTORIYA ULMAN	185273	Election Judge Compensati	11/12/18	01020076152	ELECTION JUDGES PER DIEM	170.00
291	268522	NICOLETTE FRICANO	185275	Election Judge Compensati	11/12/18	01020076152	ELECTION JUDGES PER DIEM	170.00
292	268523	MARK NEFF	185277	Election Judge Compensati	11/12/18	01020076152	ELECTION JUDGES PER DIEM	160.00
293	268524	JULIA DEDIC	185278	Election Judge Compensati	11/12/18	01020076152	ELECTION JUDGES PER DIEM	150.00

Vendor#	Name	Invoice #	Description	Date	Budget #	Account Description	Dist	Amount
294	268525	ALEXIS OSEI-KOFI	185281	Election Judge Compensati	11/12/18	01020076152	ELECTION JUDGES PER DIEM	150.00
295	268526	PATRICIA RADDENBACH	185282	Election Judge Compensati	11/12/18	01020076152	ELECTION JUDGES PER DIEM	140.00
296	268527	NITYA CHAGOOR	185283	Election Judge Compensati	11/12/18	01020076152	ELECTION JUDGES PER DIEM	170.00
297	268528	HIBA DURRANI	185284	Election Judge Compensati	11/12/18	01020076152	ELECTION JUDGES PER DIEM	170.00
298	268529	ANYA ZAREMBSKI	185287	Election Judge Compensati	11/12/18	01020076152	ELECTION JUDGES PER DIEM	150.00
299	268530	ABIGAIL KEYS	185289	Election Judge Compensati	11/12/18	01020076152	ELECTION JUDGES PER DIEM	170.00
300	268531	KRUPA PARMAR	185290	Election Judge Compensati	11/12/18	01020076152	ELECTION JUDGES PER DIEM	170.00
301	268532	ASHLYN PEARSON	185291	Election Judge Compensati	11/12/18	01020076152	ELECTION JUDGES PER DIEM	150.00
302	268533	ENAN SRIVASTAVA	185292	Election Judge Compensati	11/12/18	01020076152	ELECTION JUDGES PER DIEM	150.00
303	268534	ANNABETH WALSH	185293	Election Judge Compensati	11/12/18	01020076152	ELECTION JUDGES PER DIEM	150.00
304	268535	MCKAYLA BARNES	185294	Election Judge Compensati	11/12/18	01020076152	ELECTION JUDGES PER DIEM	150.00
305	268536	BEATRICE EGNER	185296	Election Judge Compensati	11/12/18	01020076152	ELECTION JUDGES PER DIEM	160.00
306	268537	ELIZABETH BOONE	185299	Election Judge Compensati	11/12/18	01020076152	ELECTION JUDGES PER DIEM	140.00
307	268538	NORMAN HERNANDEZ	185300	Election Judge Compensati	11/12/18	01020076152	ELECTION JUDGES PER DIEM	170.00
308	268539	BETH IVY-HERNANDEZ	185301	Election Judge Compensati	11/12/18	01020076152	ELECTION JUDGES PER DIEM	170.00
309	268540	SLOANE JOHNSON	185303	Election Judge Compensati	11/12/18	01020076152	ELECTION JUDGES PER DIEM	150.00
310	268541	ALENNNA MARTIN DEL CAMPO	185304	Election Judge Compensati	11/12/18	01020076152	ELECTION JUDGES PER DIEM	150.00
311	268542	HAERIS AHMED	185305	Election Judge Compensati	11/12/18	01020076152	ELECTION JUDGES PER DIEM	150.00
312	268543	JULIA RENEE GOMEZ	185306	Election Judge Compensati	11/12/18	01020076152	ELECTION JUDGES PER DIEM	170.00
313	268544	NATALIE SMITH	185307	Election Judge Compensati	11/12/18	01020076152	ELECTION JUDGES PER DIEM	150.00
314	268545	VIVIAN LA	185309	Election Judge Compensati	11/12/18	01020076152	ELECTION JUDGES PER DIEM	150.00
315	268546	FRANK RADDENBACH	185310	Election Judge Compensati	11/12/18	01020076152	ELECTION JUDGES PER DIEM	140.00
316	268547	AMYA REEDY	185311	Election Judge Compensati	11/12/18	01020076152	ELECTION JUDGES PER DIEM	150.00
317	268548	AJUNJE VIRK	185312	Election Judge Compensati	11/12/18	01020076152	ELECTION JUDGES PER DIEM	170.00
318	268549	KAIJA HARLOW	185313	Election Judge Compensati	11/12/18	01020076152	ELECTION JUDGES PER DIEM	150.00
319	268550	CATHLEEN ZBYLUT	185317	Election Judge Compensati	11/12/18	01020076152	ELECTION JUDGES PER DIEM	150.00
320	268551	YVONNE RATLEDGE	185321	Election Judge Compensati	11/12/18	01020076152	ELECTION JUDGES PER DIEM	150.00
321	268552	ANTHY TRAN	185322	Election Judge Compensati	11/12/18	01020076152	ELECTION JUDGES PER DIEM	150.00
322	268553	ERIN DENSBERGER	185328	Election Judge Compensati	11/12/18	01020076152	ELECTION JUDGES PER DIEM	150.00
323	268554	MAURA MCCOY	185330	Election Judge Compensati	11/12/18	01020076152	ELECTION JUDGES PER DIEM	150.00
324	268555	ALEXANDRIA RUGGIERO	185331	Election Judge Compensati	11/12/18	01020076152	ELECTION JUDGES PER DIEM	170.00
325	268556	MATTHEW TRAKSZELIS	185332	Election Judge Compensati	11/12/18	01020076152	ELECTION JUDGES PER DIEM	150.00
326	268557	KAREN BISTRAIN	185333	Election Judge Compensati	11/12/18	01020076152	ELECTION JUDGES PER DIEM	150.00
327	268558	ZOHAB FAROOQ	185334	Election Judge Compensati	11/12/18	01020076152	ELECTION JUDGES PER DIEM	170.00
328	268559	EMAD MIRZA	185336	Election Judge Compensati	11/12/18	01020076152	ELECTION JUDGES PER DIEM	170.00
329	268560	JULIANA SALINAS	185341	Election Judge Compensati	11/12/18	01020076152	ELECTION JUDGES PER DIEM	170.00
330	268561	RENEE STERNBERG	185342	Election Judge Compensati	11/12/18	01020076152	ELECTION JUDGES PER DIEM	140.00
331	268562	ALEJANDRA HERNANDEZ	185343	Election Judge Compensati	11/12/18	01020076152	ELECTION JUDGES PER DIEM	150.00
332	268563	LUGANO MWAKATAPANYA	185344	Election Judge Compensati	11/12/18	01020076152	ELECTION JUDGES PER DIEM	150.00
333	268564	GRIFFIN GILLESPIE	185347	Election Judge Compensati	11/12/18	01020076152	ELECTION JUDGES PER DIEM	150.00
334	268565	JESSICA LOPEZ	185349	Election Judge Compensati	11/12/18	01020076152	ELECTION JUDGES PER DIEM	150.00
335	268566	JACOB MILLS	185350	Election Judge Compensati	11/12/18	01020076152	ELECTION JUDGES PER DIEM	150.00
336	268567	SHEILA ERRAMILLI	185352	Election Judge Compensati	11/12/18	01020076152	ELECTION JUDGES PER DIEM	150.00
337	268568	JULIE KISER	185353	Election Judge Compensati	11/12/18	01020076152	ELECTION JUDGES PER DIEM	170.00
338	268569	DAVID ROGERS	185354	Election Judge Compensati	11/12/18	01020076152	ELECTION JUDGES PER DIEM	170.00
339	268570	ALEX SALINAS	185355	Election Judge Compensati	11/12/18	01020076152	ELECTION JUDGES PER DIEM	150.00
340	268571	FRANCESCA LAUBE	185356	Election Judge Compensati	11/12/18	01020076152	ELECTION JUDGES PER DIEM	170.00
341	268572	JOSEPH MCGAVIN	185357	Election Judge Compensati	11/12/18	01020076152	ELECTION JUDGES PER DIEM	160.00
342	268573	ELISA ONEILL	185358	Election Judge Compensati	11/12/18	01020076152	ELECTION JUDGES PER DIEM	170.00

Vendor#	Name	Invoice #	Description	Date	Budget #	Account Description	Dist Amount	
343	268574	JAMES ONEILL	185359	Election Judge Compensati	11/12/18	01020076152	ELECTION JUDGES PER DIEM	150.00
344	268575	JOHN ONEILL	185360	Election Judge Compensati	11/12/18	01020076152	ELECTION JUDGES PER DIEM	150.00
345	268576	LINDA PETZKE	185361	Election Judge Compensati	11/12/18	01020076152	ELECTION JUDGES PER DIEM	170.00
346	268577	SARA HANRATTY	185362	Election Judge Compensati	11/12/18	01020076152	ELECTION JUDGES PER DIEM	150.00
347	268578	TEJASWI NUNNA	185363	Election Judge Compensati	11/12/18	01020076152	ELECTION JUDGES PER DIEM	150.00
348	268579	SANJNA REDDY	185364	Election Judge Compensati	11/12/18	01020076152	ELECTION JUDGES PER DIEM	150.00
349	268580	RAHILA REHMAN	185365	Election Judge Compensati	11/12/18	01020076152	ELECTION JUDGES PER DIEM	170.00
350	268581	THERESA TRIMBORN	185366	Election Judge Compensati	11/12/18	01020076152	ELECTION JUDGES PER DIEM	150.00
351	268582	HANNAH DORMADY	185371	Election Judge Compensati	11/12/18	01020076152	ELECTION JUDGES PER DIEM	170.00
352	268583	STEPHEN KNUTSON	185372	Election Judge Compensati	11/12/18	01020076152	ELECTION JUDGES PER DIEM	150.00
353	268584	PAULINE DUGGAN	185375	Election Judge Compensati	11/12/18	01020076152	ELECTION JUDGES PER DIEM	175.00
354	268585	MARY HOLT	185376	Election Judge Compensati	11/12/18	01020076152	ELECTION JUDGES PER DIEM	160.00
355	268586	BELINDA TRAYWICK	185380	Election Judge Compensati	11/12/18	01020076152	ELECTION JUDGES PER DIEM	170.00
356	268587	JESSICA FINNERTY	185383	Election Judge Compensati	11/12/18	01020076152	ELECTION JUDGES PER DIEM	150.00
357	268588	JAYDEN YARBROUGH	185385	Election Judge Compensati	11/12/18	01020076152	ELECTION JUDGES PER DIEM	150.00
358	268589	BRIGGS KREMPSKI	185388	Election Judge Compensati	11/12/18	01020076152	ELECTION JUDGES PER DIEM	150.00
359	268590	PATRICIA WIET	185390	Election Judge Compensati	11/12/18	01020076152	ELECTION JUDGES PER DIEM	170.00
360	268591	GRACE LESLIE	185406	Election Judge Compensati	11/12/18	01020076152	ELECTION JUDGES PER DIEM	150.00
361	268592	TIMOTHY CORDUAN	185412	Election Judge Compensati	11/12/18	01020076152	ELECTION JUDGES PER DIEM	170.00
362	268593	H GENGE	185413	Election Judge Compensati	11/12/18	01020076152	ELECTION JUDGES PER DIEM	170.00
363	268594	JAMES WULF	185418	Election Judge Compensati	11/12/18	01020076152	ELECTION JUDGES PER DIEM	150.00
364	268595	MARGARET SMITH	185421	Election Judge Compensati	11/12/18	01020076152	ELECTION JUDGES PER DIEM	150.00
365	268596	EDITH WATT	185424	Election Judge Compensati	11/12/18	01020076152	ELECTION JUDGES PER DIEM	140.00
366	268597	ELAINE KOLIOPOULOS	185426	Election Judge Compensati	11/12/18	01020076152	ELECTION JUDGES PER DIEM	160.00
367	268598	JUSTIN BOLTE	185428	Election Judge Compensati	11/12/18	01020076152	ELECTION JUDGES PER DIEM	150.00
368	268599	MADISON BOLTE	185429	Election Judge Compensati	11/12/18	01020076152	ELECTION JUDGES PER DIEM	170.00
369	268600	BEAU BROWN	185434	Election Judge Compensati	11/12/18	01020076152	ELECTION JUDGES PER DIEM	150.00
370	268601	BENJAMIN SCHROEDER	185437	Election Judge Compensati	11/12/18	01020076152	ELECTION JUDGES PER DIEM	150.00
371	268602	MATTIE CHAPMAN	185440	Election Judge Compensati	11/12/18	01020076152	ELECTION JUDGES PER DIEM	150.00
372	268603	ILISSA DELANGE	185442	Election Judge Compensati	11/12/18	01020076152	ELECTION JUDGES PER DIEM	170.00
373	268604	LAUREN DELANGE	185443	Election Judge Compensati	11/12/18	01020076152	ELECTION JUDGES PER DIEM	170.00
374	268605	JOSHUA BECK	185449	Election Judge Compensati	11/12/18	01020076152	ELECTION JUDGES PER DIEM	170.00
375	268606	KENNETH CASELBERRY	185450	Election Judge Compensati	11/12/18	01020076152	ELECTION JUDGES PER DIEM	150.00
376	268607	ALLIE VANDERGRIFT	185454	Election Judge Compensati	11/12/18	01020076152	ELECTION JUDGES PER DIEM	150.00
							57,410.00*	
377	011427	MARLENE M ANDOE	185094	Election Judge Compensati	11/12/18	01020076205	ELECTION JUDGES MILEAGE	24.58
378	020104	DONNA BAILEY	185189	Election Judge Compensati	11/12/18	01020076205	ELECTION JUDGES MILEAGE	28.36
379	020123	KATHRYN E. BAHR	185217	Election Judge Compensati	11/12/18	01020076205	ELECTION JUDGES MILEAGE	5.00
380	020199	ROBERT R. BAZAN	185179	Election Judge Compensati	11/12/18	01020076205	ELECTION JUDGES MILEAGE	5.00
381	020521	KAREN M. BELL	185115	Election Judge Compensati	11/12/18	01020076205	ELECTION JUDGES MILEAGE	7.16
382	020553	JULIE BENNETT	185184	Election Judge Compensati	11/12/18	01020076205	ELECTION JUDGES MILEAGE	20.13
383	020564	LEROY C. BENSON	185204	Election Judge Compensati	11/12/18	01020076205	ELECTION JUDGES MILEAGE	55.38
384	020948	REY E. BLANCO	185125	Election Judge Compensati	11/12/18	01020076205	ELECTION JUDGES MILEAGE	25.80
385	021603	BRUCE J. BOWERS	185104	Election Judge Compensati	11/12/18	01020076205	ELECTION JUDGES MILEAGE	14.32
386	021854	ANTHONY L. BRIDGES	185323	Election Judge Compensati	11/12/18	01020076205	ELECTION JUDGES MILEAGE	38.36
387	021875	KIMBERLY S. BRIGGS-OTT	185419	Election Judge Compensati	11/12/18	01020076205	ELECTION JUDGES MILEAGE	20.39
388	021945	PATRICIA A BRUMMEL	185382	Election Judge Compensati	11/12/18	01020076205	ELECTION JUDGES MILEAGE	23.50
389	021970	MICHAEL R BRUNS	185105	Election Judge Compensati	11/12/18	01020076205	ELECTION JUDGES MILEAGE	10.40

Vendor#	Name	Invoice #	Description	Date	Budget #	Account Description	Dist Amount	
390	022140	KAROL J BUNDY	185403	Election Judge Compensati	11/12/18	01020076205	ELECTION JUDGES MILEAGE	18.18
391	022172	JOSEPH L. BURKE	185324	Election Judge Compensati	11/12/18	01020076205	ELECTION JUDGES MILEAGE	14.18
392	022559	JOHANNA L. BYRAM	185374	Election Judge Compensati	11/12/18	01020076205	ELECTION JUDGES MILEAGE	5.00
393	022561	MICHAEL J. BYRNE	185190	Election Judge Compensati	11/12/18	01020076205	ELECTION JUDGES MILEAGE	5.00
394	030194	CHRISTINE M. CAVANAUGH	185171	Election Judge Compensati	11/12/18	01020076205	ELECTION JUDGES MILEAGE	29.45
395	031130	KATHERINE CLARKE	185209	Election Judge Compensati	11/12/18	01020076205	ELECTION JUDGES MILEAGE	5.00
396	031220	DAVID CLINE	185405	Election Judge Compensati	11/12/18	01020076205	ELECTION JUDGES MILEAGE	12.56
397	031430	THOMAS H. COLLINS	185346	Election Judge Compensati	11/12/18	01020076205	ELECTION JUDGES MILEAGE	46.73
398	031480	DURAH J. CONNELL	185386	Election Judge Compensati	11/12/18	01020076205	ELECTION JUDGES MILEAGE	5.00
399	031540	PATRICIA A. COMER	185107	Election Judge Compensati	11/12/18	01020076205	ELECTION JUDGES MILEAGE	20.53
400	031550	STEPHEN J. CORCORAN	185387	Election Judge Compensati	11/12/18	01020076205	ELECTION JUDGES MILEAGE	14.32
401	031576	PETER P. COORDAN	185410	Election Judge Compensati	11/12/18	01020076205	ELECTION JUDGES MILEAGE	38.94
402	031578	CYNTHIA COOLEY	185258	Election Judge Compensati	11/12/18	01020076205	ELECTION JUDGES MILEAGE	10.00
403	031639	JEFFERY COX	185425	Election Judge Compensati	11/12/18	01020076205	ELECTION JUDGES MILEAGE	6.89
404	031770	KAREN CRAIG	185213	Election Judge Compensati	11/12/18	01020076205	ELECTION JUDGES MILEAGE	5.00
405	031830	CAROLE J CRUM	185295	Election Judge Compensati	11/12/18	01020076205	ELECTION JUDGES MILEAGE	19.45
406	040302	TERRY A. DEARBORN	185120	Election Judge Compensati	11/12/18	01020076205	ELECTION JUDGES MILEAGE	10.13
407	040425	LINDA DEBOLT	185095	Election Judge Compensati	11/12/18	01020076205	ELECTION JUDGES MILEAGE	5.00
408	040533	ANNE KRISTINE DELANGE	185441	Election Judge Compensati	11/12/18	01020076205	ELECTION JUDGES MILEAGE	28.25
409	041250	WILLIAM A. DOBRAN JR	185240	Election Judge Compensati	11/12/18	01020076205	ELECTION JUDGES MILEAGE	17.78
410	041512	DAVID A. DONKERS	185166	Election Judge Compensati	11/12/18	01020076205	ELECTION JUDGES MILEAGE	9.86
411	041514	ANITA M. DONKERS	185165	Election Judge Compensati	11/12/18	01020076205	ELECTION JUDGES MILEAGE	10.67
412	051453	PATRICIA A. ENGELHARDT	185378	Election Judge Compensati	11/12/18	01020076205	ELECTION JUDGES MILEAGE	5.00
413	060157	JOHN J. FAYFAR	185228	Election Judge Compensati	11/12/18	01020076205	ELECTION JUDGES MILEAGE	17.42
414	060321	SAMUEL J. FIGOLA	185232	Election Judge Compensati	11/12/18	01020076205	ELECTION JUDGES MILEAGE	13.10
415	060350	NANCY JO FINNERTY	185384	Election Judge Compensati	11/12/18	01020076205	ELECTION JUDGES MILEAGE	5.00
416	061890	RICKY A FRY	185264	Election Judge Compensati	11/12/18	01020076205	ELECTION JUDGES MILEAGE	17.42
417	070195	SHAREN L. GAVIN	185080	Election Judge Compensati	11/12/18	01020076205	ELECTION JUDGES MILEAGE	34.58
418	080937	MARY ANN HISLOP	185220	Election Judge Compensati	11/12/18	01020076205	ELECTION JUDGES MILEAGE	14.99
419	081552	JOHN HORWATH JR.	185153	Election Judge Compensati	11/12/18	01020076205	ELECTION JUDGES MILEAGE	18.64
420	081555	CHRISTIAN A. HORWATH	185152	Election Judge Compensati	11/12/18	01020076205	ELECTION JUDGES MILEAGE	5.00
421	082125	CORA JANE HUGHES	185091	Election Judge Compensati	11/12/18	01020076205	ELECTION JUDGES MILEAGE	5.00
422	091338	ANGELA M. IMBROGNO	185348	Election Judge Compensati	11/12/18	01020076205	ELECTION JUDGES MILEAGE	10.00
423	100151	MICHAEL A. JAMES	185126	Election Judge Compensati	11/12/18	01020076205	ELECTION JUDGES MILEAGE	10.13
424	101296	THOMAS L. JOHANNESSEN SR	185302	Election Judge Compensati	11/12/18	01020076205	ELECTION JUDGES MILEAGE	37.82
425	101405	DOREEN L JOHNSON	185335	Election Judge Compensati	11/12/18	01020076205	ELECTION JUDGES MILEAGE	40.52
426	101409	JACQUELINE L. JOHNSON	185288	Election Judge Compensati	11/12/18	01020076205	ELECTION JUDGES MILEAGE	10.00
427	101581	LORI J JORDAN	185279	Election Judge Compensati	11/12/18	01020076205	ELECTION JUDGES MILEAGE	12.29
428	110114	GERALD E. KAISER	185180	Election Judge Compensati	11/12/18	01020076205	ELECTION JUDGES MILEAGE	8.24
429	110171	RICHARD C. KAYER	185314	Election Judge Compensati	11/12/18	01020076205	ELECTION JUDGES MILEAGE	40.11
430	111506	JAMES E. KOCK	185118	Election Judge Compensati	11/12/18	01020076205	ELECTION JUDGES MILEAGE	5.00
431	111512	LOIS M. KONICEK	185186	Election Judge Compensati	11/12/18	01020076205	ELECTION JUDGES MILEAGE	8.24
432	120138	JEANETTE LANDERS	185211	Election Judge Compensati	11/12/18	01020076205	ELECTION JUDGES MILEAGE	26.34
433	120153	BARBARA A. LANE	185148	Election Judge Compensati	11/12/18	01020076205	ELECTION JUDGES MILEAGE	5.00
434	120157	DANIEL T. LANE	185149	Election Judge Compensati	11/12/18	01020076205	ELECTION JUDGES MILEAGE	23.51
435	120570	MICHAEL E. LESLIE	185233	Election Judge Compensati	11/12/18	01020076205	ELECTION JUDGES MILEAGE	13.64
436	120710	EDWARD WEIL LICHTENSTEIN	185285	Election Judge Compensati	11/12/18	01020076205	ELECTION JUDGES MILEAGE	19.31
437	120960	PATRICIA A. LIPPOLD	185367	Election Judge Compensati	11/12/18	01020076205	ELECTION JUDGES MILEAGE	38.36
438	122140	MARGARET SMITH-LUBINSKI	185436	Election Judge Compensati	11/12/18	01020076205	ELECTION JUDGES MILEAGE	5.00

Vendor#	Name	Invoice #	Description	Date	Budget #	Account Description	Dist Amount	
439	122151	CARIN LUGO	185427	Election Judge Compensati	11/12/18	01020076205	ELECTION JUDGES MILEAGE	20.39
440	130018	JUDITH M. MAECHTLE	185236	Election Judge Compensati	11/12/18	01020076205	ELECTION JUDGES MILEAGE	32.29
441	130075	ROBERT W. MADISON	185329	Election Judge Compensati	11/12/18	01020076205	ELECTION JUDGES MILEAGE	35.93
442	130120	BETTY MALONE	185431	Election Judge Compensati	11/12/18	01020076205	ELECTION JUDGES MILEAGE	5.00
443	130133	PAUL H. MALOHN	185399	Election Judge Compensati	11/12/18	01020076205	ELECTION JUDGES MILEAGE	11.35
444	130195	THOMAS R. MARUNDE	185286	Election Judge Compensati	11/12/18	01020076205	ELECTION JUDGES MILEAGE	5.00
445	130245	JUDY C. MARSH	185247	Election Judge Compensati	11/12/18	01020076205	ELECTION JUDGES MILEAGE	10.00
446	130332	MARY R MC CRACKEN	185379	Election Judge Compensati	11/12/18	01020076205	ELECTION JUDGES MILEAGE	12.43
447	130953	FRANCINE E. MILLER	185445	Election Judge Compensati	11/12/18	01020076205	ELECTION JUDGES MILEAGE	5.00
448	130956	RONALD ROY MILLER	185446	Election Judge Compensati	11/12/18	01020076205	ELECTION JUDGES MILEAGE	21.20
449	131542	DIANA LYNN MORGANEGG	185119	Election Judge Compensati	11/12/18	01020076205	ELECTION JUDGES MILEAGE	6.35
450	131561	J. DONALD MORRIS	185400	Election Judge Compensati	11/12/18	01020076205	ELECTION JUDGES MILEAGE	22.70
451	131665	VIRGINIA K. MULLINER	185092	Election Judge Compensati	11/12/18	01020076205	ELECTION JUDGES MILEAGE	24.58
452	140516	NANCY K. NESS	185432	Election Judge Compensati	11/12/18	01020076205	ELECTION JUDGES MILEAGE	33.65
453	150915	VIRGIL G OSTRENG	185265	Election Judge Compensati	11/12/18	01020076205	ELECTION JUDGES MILEAGE	22.10
454	160562	PARALEE M. PERKINS	185197	Election Judge Compensati	11/12/18	01020076205	ELECTION JUDGES MILEAGE	32.96
455	160839	KAY PHILLIPS	185131	Election Judge Compensati	11/12/18	01020076205	ELECTION JUDGES MILEAGE	20.40
456	161822	KYLE ALLEN PRICE	185143	Election Judge Compensati	11/12/18	01020076205	ELECTION JUDGES MILEAGE	15.40
457	180118	DOROTHY RAGSDALE	185221	Election Judge Compensati	11/12/18	01020076205	ELECTION JUDGES MILEAGE	15.53
458	180167	RUTH ANN RADER	185137	Election Judge Compensati	11/12/18	01020076205	ELECTION JUDGES MILEAGE	5.00
459	180430	GERGORY M. REDFERN	185272	Election Judge Compensati	11/12/18	01020076205	ELECTION JUDGES MILEAGE	38.90
460	180918	KATHLEEN C. RICHMOND	185088	Election Judge Compensati	11/12/18	01020076205	ELECTION JUDGES MILEAGE	30.26
461	181580	BETH A. ROUSSEAU	185086	Election Judge Compensati	11/12/18	01020076205	ELECTION JUDGES MILEAGE	17.29
462	181900	GREGORY J. ROZBORSKI	185100	Election Judge Compensati	11/12/18	01020076205	ELECTION JUDGES MILEAGE	27.55
463	181915	BRENDA J. ROZBORSKI	185099	Election Judge Compensati	11/12/18	01020076205	ELECTION JUDGES MILEAGE	5.00
464	190400	GEORGIA G SCOGGIN	185134	Election Judge Compensati	11/12/18	01020076205	ELECTION JUDGES MILEAGE	10.13
465	190460	DENNIS L. SCHOLTZ	185112	Election Judge Compensati	11/12/18	01020076205	ELECTION JUDGES MILEAGE	10.40
466	190465	KATHLEEN M. SCHOLTZ	185113	Election Judge Compensati	11/12/18	01020076205	ELECTION JUDGES MILEAGE	5.00
467	190518	DONNA J. SEBBY	185138	Election Judge Compensati	11/12/18	01020076205	ELECTION JUDGES MILEAGE	6.35
468	192045	VIRGINIA A STIBBE	185377	Election Judge Compensati	11/12/18	01020076205	ELECTION JUDGES MILEAGE	11.35
469	192085	REBECCA E. STRYKOWSKI	185145	Election Judge Compensati	11/12/18	01020076205	ELECTION JUDGES MILEAGE	7.16
470	192102	CYNTHIA STRYKOWSKI	185144	Election Judge Compensati	11/12/18	01020076205	ELECTION JUDGES MILEAGE	5.00
471	200915	SHAWN L. TORRES	185447	Election Judge Compensati	11/12/18	01020076205	ELECTION JUDGES MILEAGE	21.74
472	211820	DEBRA L. UPSHAW	185451	Election Judge Compensati	11/12/18	01020076205	ELECTION JUDGES MILEAGE	52.13
473	230835	DANA W WHITE	185368	Election Judge Compensati	11/12/18	01020076205	ELECTION JUDGES MILEAGE	10.00
474	231370	STANLEY C. WOOLLEY	185103	Election Judge Compensati	11/12/18	01020076205	ELECTION JUDGES MILEAGE	15.26
475	251934	RAMONA B. YOUNG	185117	Election Judge Compensati	11/12/18	01020076205	ELECTION JUDGES MILEAGE	5.00
476	263814	JAMES W DAVIDSON	185231	Election Judge Compensati	11/12/18	01020076205	ELECTION JUDGES MILEAGE	5.00
477	265947	DORIS FOWLER	185101	Election Judge Compensati	11/12/18	01020076205	ELECTION JUDGES MILEAGE	5.00
478	265948	DEBRA STYMACKS	185102	Election Judge Compensati	11/12/18	01020076205	ELECTION JUDGES MILEAGE	12.56
479	265952	THOMAS LENNON	185121	Election Judge Compensati	11/12/18	01020076205	ELECTION JUDGES MILEAGE	5.00
480	265973	LORILYN HERNANDEZ	185162	Election Judge Compensati	11/12/18	01020076205	ELECTION JUDGES MILEAGE	49.44
481	266007	NINA HEERMANN	185246	Election Judge Compensati	11/12/18	01020076205	ELECTION JUDGES MILEAGE	20.53
482	266022	HARVEY GOODWIN	185268	Election Judge Compensati	11/12/18	01020076205	ELECTION JUDGES MILEAGE	15.00
483	266043	MARK CRAIG	185214	Election Judge Compensati	11/12/18	01020076205	ELECTION JUDGES MILEAGE	16.34
484	266045	TIMOTHY RILEY	185224	Election Judge Compensati	11/12/18	01020076205	ELECTION JUDGES MILEAGE	54.03
485	266073	MARK TOLEFREE	185414	Election Judge Compensati	11/12/18	01020076205	ELECTION JUDGES MILEAGE	5.00
486	266080	JEAN FLETCHER	185435	Election Judge Compensati	11/12/18	01020076205	ELECTION JUDGES MILEAGE	40.24
487	268477	CATHERINE RAMIREZ	185081	Election Judge Compensati	11/12/18	01020076205	ELECTION JUDGES MILEAGE	10.00

Vendor#	Name	Invoice #	Description	Date	Budget #	Account Description	Dist Amount
488	268504	PATRICK KREMER	185200	Election Judge Compensati	11/12/18	01020076205 ELECTION JUDGES MILEAGE	14.18
489	268536	BEATRICE EGNER	185296	Election Judge Compensati	11/12/18	01020076205 ELECTION JUDGES MILEAGE	5.00
490	268537	ELIZABETH BOONE	185299	Election Judge Compensati	11/12/18	01020076205 ELECTION JUDGES MILEAGE	10.00
491	268569	DAVID ROGERS	185354	Election Judge Compensati	11/12/18	01020076205 ELECTION JUDGES MILEAGE	26.99
492	268573	ELISA ONEILL	185358	Election Judge Compensati	11/12/18	01020076205 ELECTION JUDGES MILEAGE	15.00
493	268575	JOHN ONEILL	185360	Election Judge Compensati	11/12/18	01020076205 ELECTION JUDGES MILEAGE	27.42
494	268586	BELINDA TRAYWICK	185380	Election Judge Compensati	11/12/18	01020076205 ELECTION JUDGES MILEAGE	5.00
495	268591	GRACE LESLIE	185406	Election Judge Compensati	11/12/18	01020076205 ELECTION JUDGES MILEAGE	12.56
496	268592	TIMOTHY CORDUAN	185412	Election Judge Compensati	11/12/18	01020076205 ELECTION JUDGES MILEAGE	5.00
497	268596	EDITH WATT	185424	Election Judge Compensati	11/12/18	01020076205 ELECTION JUDGES MILEAGE	20.39
498	268603	LISSA DELANGE	185442	Election Judge Compensati	11/12/18	01020076205 ELECTION JUDGES MILEAGE	5.00
499	268604	LAUREN DELANGE	185443	Election Judge Compensati	11/12/18	01020076205 ELECTION JUDGES MILEAGE	5.00
							2,091.42*
Total ELECTION COSTS							59,501.42*
GRAND TOTAL							59,501.42**

The 17-28 Ordinance that is being presented to the COW today is purposely Vague and has many references to the National Rifle Association "NRA" Standards in it.

It was Drafted by a gentleman by the last name of Lombardo, who has had a long standing and a close personal relationship with PBZ Chairman Davidson. Mr. Lombardo became the County's PBZ Consultant for this 17-28 Ordinance and is one of the Leading NRA Advocates in the Chicagoland Metro Area. Why is the NRA dictating Gun Range Standards for Kendall County?

- 1) 7.01. D.33 (a) NRA Handbook "suggested" Standards referenced can be changed by the NRA. Most County Legislation is not dependent on Lobbyist drafting regulatory language standards.
- 2) 7.01. D.33 (G) What is the specific definition of "Designated Qualified Person" the only requirement appears to be the word "Knowledgeable". Both terms are very Vague.
- 3) 7.01. D.33 (H) Requirement for only one range flag, a sign, cone or Red Light, seems to be a bare minimum notification requirement while Live Firing is Occurring.
- 4) 7.01. D.33 (N) Insurance Requirement Standard is set at a "Level Standard and Customary for Outdoor Target Practice or Shooting Range. Again Very Vague Language is being used.
- 5) 7.01.D.33 (R) How Many of the Existing Gun Ranges have applied and received a Land Use Permit for Gun Range Operations from Kendall County. Has this research ever been performed to confirm designated permitting procedures were adhered to? What is actual date is being used to establish Grandfather Status? I am being told that the Land Use Zoning Rules/Regulation, the formal application for Land Use permitting and the written procedures for Land Use Applications dates back to the Late 1940's.
- 6) 10.03. B.4 (a) 1 - Lead Management Standards are established by the NRA or? Why three different Lead Management Standards Criteria? Again very Vague Language and possible floating or changing standard.
- 7) 10.03. b – Range Layout conforms to NRA standards. At 11-13-2018 PBZ, Federal Dept. of Energy Gun Range Standards were presented in Alternate Proposal (COW Packet 57 of 90) drafted by the Citizens off Rt. 126 and Old Ridge Road, which is conveniently not in your packet. Only the first page of that Citizen Proposal is located in the today's COW Packet. If you want to see the proposal, reference page 35 to 59 of 177 of the 11-13-2018 PBZ Packet. It is a very detailed and specific proposal with many relevant diagrams. Much of the info in this Citizen Proposal regarding Gun Range Design and Safety Standards came from the Kendall County Sheriff Dept. Staff. Yet was Ignored at Tuesday's PBZ meeting.
- 8) The Citizens attending the PBZ Meetings and have watch the drafting of 17-28 also produced a 2013 State Law. 55 ILCS 5/5-1117. This State Law was discussed at the 11-13-2018 Law, Legislative and Justice Meeting on Tuesday. Ms. Gilmour referenced this Law at the PBZ Meeting, yet this law is not being referenced in 17-28 for any new Gun Ranges.
- 9) I suggested to the Kendall County Plan Commission to regulate gun ranges and establish gun range safety requirements by type of Fire Arm and in three categories, shot gun, hand gun and long rifle. The Plan Commission Like that idea, but it was rejected by the PBZ Committee. Mr. Davidson likes A-1 Special Use. I question if we have the staffing to enforce A-1 Special Use Conditions.
- 10) 17-28 has received a Negative Recommendation from the Kendall County Plan Commission and the Zoning Board of Appeals. It came out of the PBZ Committee on Tuesday with no guidance. No Motion or Second, nor up or down vote. Before the PBZ Committee even started their Tuesday night meeting, 17-28 had already been placed on today's COW Agenda.

From: TODD MILLIRON

WHEREAS,....

NOW, THEREFORE, BE IT ORDAINED, the Kendall County Board hereby amends Sections 7.01.D.32, 7.01.D.33 and 10.03B.4 of the Kendall County Zoning Ordinance as provided:

- I. Recitals: The recitals set forth above are incorporated as if fully set forth herein.
- II. Amended Text: The existing language of Section 7.01.D.32 is hereby deleted and replaced with the following:

7.01.D.33 Outdoor Commercial Sporting Activities including but not limited to swimming facilities and motocross sports. Appropriate regulations for lighting, noise and hours of operation shall be included in the conditions. **Outdoor commercial sporting activities are activities including but not limited to polo clubs and similar uses, to exclude: outdoor target practice, athletic fields with lights, paintball facilities, and riding stables.**

- III. Deleted Text: The existing language of Section 7.01.D.33 is hereby deleted in full.
- IV. Amended Text: The existing language of Section 10.03.B.4 is hereby deleted and replaced with the following:

10.03.B.4 Outdoor Commercial Sporting Activities including but not limited to swimming facilities and motocross sports. Appropriate regulations for lighting, noise and hours of operation shall be included in the conditions. **Outdoor commercial sporting activities are activities including but not limited to polo clubs and similar uses, to exclude: outdoor target practice, athletic fields with lights, paintball facilities, and riding stables.**

- V. Amended Text: The existing language of Section 10.03.B.4 is hereby deleted and replaced with the following:

10.03.B.4 Outdoor Target Practice or Shooting, **to include all shooting on commercial property (including all property inviting the retail sale of goods and/or services) and shooting ranges accommodating more than two people shooting at the same time but otherwise not including private shooting in your own yard, with the following conditions:**

- a. ~~Requires conformity with NRA standards; provide appropriate berming based on surrounding land use and type(s) of firearms to be used. Such berming shall generally be consistent with standards established in the NRA Source Book.~~ **Requires conformity with U.S. Government Range Design Criteria, as that in U.S. Department of Energy Range Design Criteria, including adherence to design standards, concern for community growth, care for Surface Danger Zones (SDZs) (which require**

considerable SDZs for target shooting or allow for baffle systems with canopy shields and berms to contain projectiles), and support facilities.

I. The filings should include:

- A. Appropriate plans for all facilities, drafted by engineers and/or architects as appropriate,
- B. A layout of the proposed range with a safety fan in a cross section and top view,
- C. A safety plan describing, at a minimum, the duties and qualifications range supervisors and measures planned to be taken to ensure safety of all participants, bystanders, persons and property in the environs, and to prevent projectiles from escaping the property, reviewed by a qualified range master,
- D. A noise plan,
- E. An environmental impact/stewardship plan,
- F. A narrative describing, in detail, the proposed use and nature of the range, stating, at a minimum, the type of range (i.e. public, private, not-for-profit, or government), the type(s) of firearms and targets expected to be used and the proposed days and hours of operation,
- G. As a separate plan or included in another plan, a hazardous waste plan addressing lead management conforming to all Kendall County regulations, State of Illinois laws, and United States Environmental Protection Agency's best management practices standards and regulations, and
- H. A water and drainage plan to be approved by the Kendall County Planning, Building, and Zoning Office.
- I. Any changes to the above required studies and plans shall be promptly forwarded to the Kendall County Planning, Building and Zoning Department.

II. Safety Danger Zones (SDZs) should be established to contain all projectiles and debris caused by firing ammunition as dictated by U.S. Range Design Criteria. SDZ Dimensions are dictated by the types of ammunition, types of targets, and types of firing activities allowed on the range. A basic SDZ consists of three parts: impact area, ricochet area, and secondary danger area.

- A. The primary danger area established for the impact of all rounds extends 5° to either side of the left and right limits of fire and downrange to the maximum range of any ammunition to be used on the range.
- B. The ricochet area is 5° to either side of the impact area and extends downrange to the maximum range of any ammunition to be used on the range.
- C. The secondary danger area is that area paralleling, and 100 yards outside of, the outermost limits of the ricochet area and extending downrange to the maximum range of any ammunition to be used on the range. See Table 1: Maximum Range of Small Arms Ammunition.
- D. Boundaries of SDZs must be posted with permanent signs warning persons of the danger of the live-fire range and prohibiting trespassing.

The signs must be posted in a way that will ensure a person cannot enter the SDZ without seeing at least one legible sign.

- E. Limit of fire markers, both external and internal, must be used to denote right and left limits of fire. Where cross firing is to be conducted, internal limit markers must be emplaced to denote internal right or left limits of fire from specific firing positions.
 - F. To change the size and shape of an SDZ, baffles shall be installed. Partial and full baffle systems consist of the following components: overhead baffles, a canopy shield over firing points, bullet impact berm, and side berms, sidewalls, or side baffles. A fully baffled range must be constructed so all direct fire can be contained within the range.
 - G. For further illustration of surface danger zones, ricochet areas, appropriate berms, baffles, canopies, and layouts, see illustrations in Attachments.
- b. Requires minimum parcel size of ~~5~~ 20 acres, ~~depending on the venue.~~
 - c. Must have a sign that lists allowed firearm types, rules of operation; hearing and vision protection required.
 - d. State recognized, nationally recognized or NRA certified range supervisor must be present at all times when firing is taking place.
 - e. A range flag must be flown, a sign prominently displayed, or a red light lit at all times that firing is taking place.
 - f. The outdoor target practice or shooting range allowed by this special use permit shall provide the Kendall County Planning, Building and Zoning Department proof of accident and liability insurance prior to the commencement of operations; the insurance amount shall be at a level standard and customary for an outdoor target practice or shooting range and must, at a minimum, include coverage for property damage, bodily injury or death, and personal injury protection. The insurance policy must be purchased from an A++ rated (or equivalent) insurance company. An insurance policy meeting the above requirements must be maintained during the duration of the special use permit.
 - g. ~~Hours and days of operation shall be specified by the Special Use Permit as determined by the County Board.~~ Hours and days of operation shall be specified by the Special Use Permit as determined by the County Board, not to exceed one hour after sunrise to one hour before sunset.
 - h. ~~Access must be controlled by a lockable gate.~~ Access must be controlled by a locked and gated entrance. The range proper shall be gated and fenced such in a manner so as to prohibit entrance on to the property by members of the public and shall have signs posted at one hundred foot (100') intervals warning members of the public of the danger.
 - i. Law enforcement, fire and emergency personnel shall have security access in addition to and as required by all applicable state and federal laws.
 - j. Hazardous waste plan addressing lead management required.
 - k. No discharge of lead shot into wetland.
 - l. Must be at least ~~1,000~~ 3,000 feet from existing dwellings and property lines of schools, daycares, places of worship and airstrips.

- m. Proposals shall include site plans with safety plans, including a layout of the range with a safety fan in cross section and top view in accordance with U.S. Department of Energy criteria for Range Design.
- n. No alcohol or other drugs are allowed on the premises. No person may be under the influence of such substances while on the range and range premises.
- o. No projectiles shall leave the boundaries of the site.
- p. All applicable Federal, State and County rules and regulations shall be adhered to.
- q. Must meet all requirements of the Kendall County Health Department.
- r. Water and drainage plans must be approved by the Kendall County Planning, Building and Zoning Office.
- s. Signage is permitted but must meet the Sign Ordinance regulations of Section 12 of the Zoning Ordinance.
- t. Lighting shall meet the standards of Section 11.02.F.12.d of the Zoning Ordinance.
- u. Must adhere to the Performance standards of Section 10.01.F of the Zoning Ordinance (Not more than sixty percent (60% of the area of the lot may be covered by buildings or structures, including accessory buildings).
- v. The range shall abide by the following noise regulations (so as not to exceed allowable residential noise in accordance with Kendall County Illinois Ordinance No. 13-18):
 - I. Day Hours: No person shall cause or allow the emission of sound during daytime hours (7:00 A.M. to 10:00 P.M.) from any noise source to any receiving residential land which exceeds sixty (60) dBA when measured at any point within such receiving residential land; provided, however, that point of measurement shall be on the property line of the complainant.
 - II. Night Hours: No person shall cause or allow the emission of sound during nighttime hours (10:00 P.M. to 7:00 A.M.) from any noise source to any receiving residential land which exceeds fifty-five (55) dBA when measured at any point within such receiving residential land; provided, however, that point of measurement shall be on the property line of the complainant.
- w. Outdoor target practice and public or private shooting ranges operating under permit prior to the date of the adoption of this ordinance [DATE] shall be exempt from this sub-section of the Zoning Ordinance, but they shall follow the restrictions on their respective special use permits.
- x. Outdoor target practice and public or private shooting ranges established after the date of the adoption of this ordinance [DATE] must comply with the above regulations or secure applicable variances.

Table 1. Maximum Range of Small Arms Ammunition

Maximum Range of Small Arms Ammunition	
Caliber	Maximum range of small arms ammunition (distance in meters/yards)
.22 long rifle	1400/1531
.38 revolver	
Ball, M41	1600/1749
Ball PGU-12/8	1900/2077
.40 pistol	
Ball	1783/1950
JHP	1908/2086
Frangible	1000/1093
.45 pistol	1500/1640
.45 submachine gun	1600/1749
.357 magnum	2160/2362
9mm pistol	1740/1902
9mm submachine gun	1920/2099
.44 magnum	2290/2504
.50 machine gun	
Ball, M33	6500/7108
AP, M26	6100/6671
12 gauge shotgun, riot 00 buckshot	600/656
.30 rifle and machine gun	
Ball, M23	3100/3390
AP, M2	4400/4811
.30 carbine	2300/2515
5.56mm rifle	
Ball, M193	3100/3390
7.62mm rifle and machine gun	
Ball, M80	4100/4483
Match, M118	4800/5249
40mm	
M79	400/437
Mk-19 40mm	2200/2406

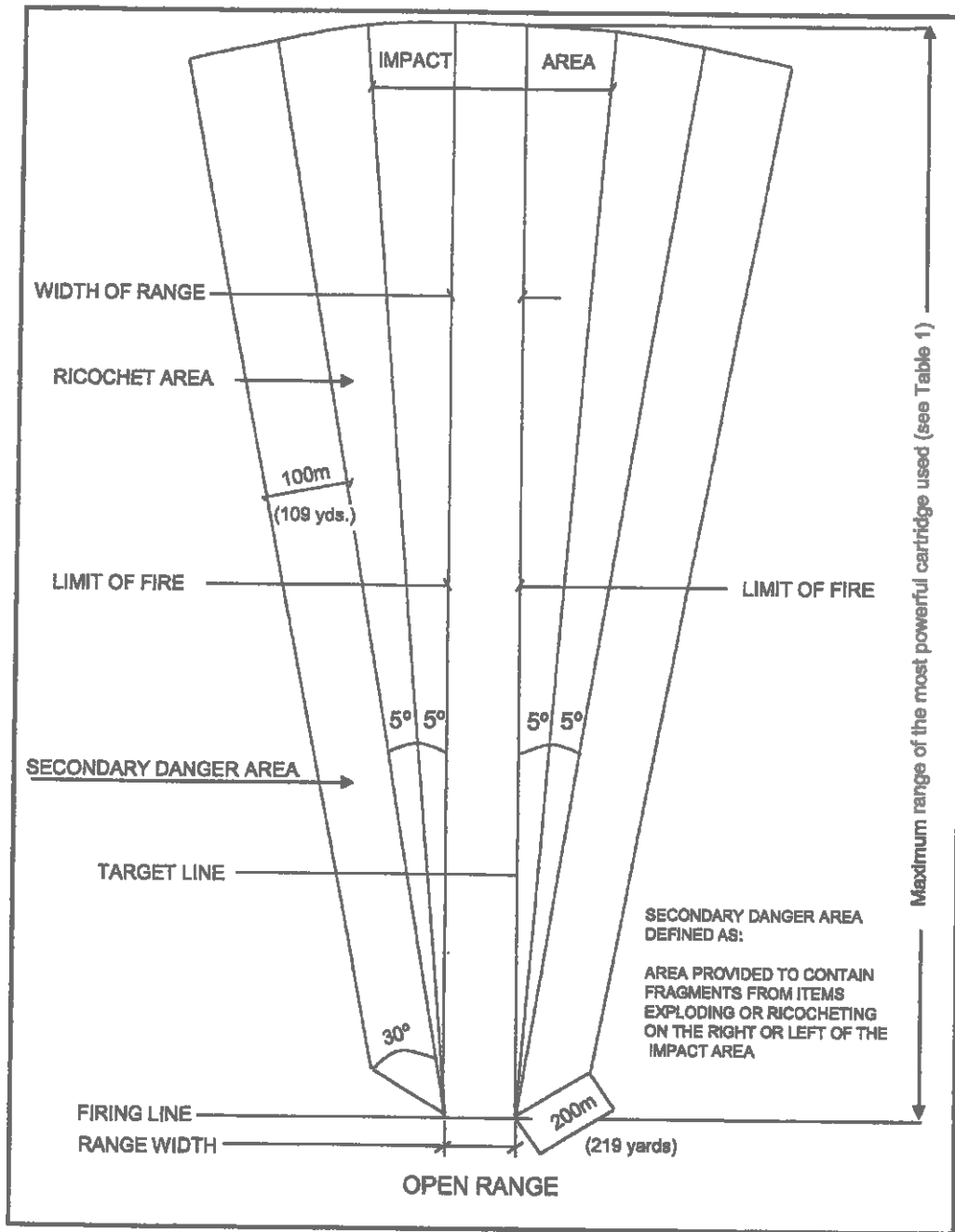

Figure 1
Surface Danger Zone for Small Arms
Firing at Fixed Ground Targets

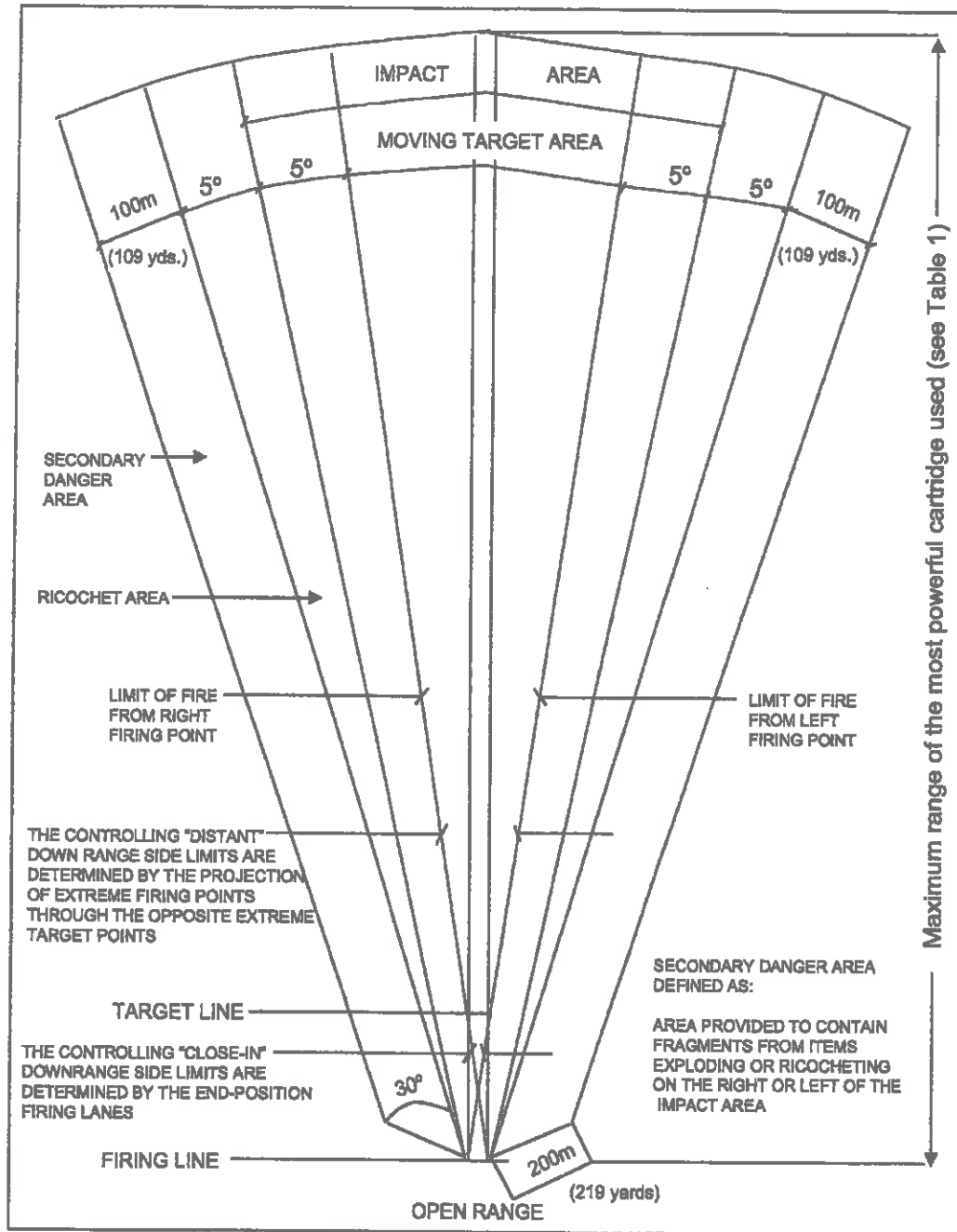

Figure 2
Surface Danger Zone for Small Arms Weapons
Firing at Moving Ground Targets

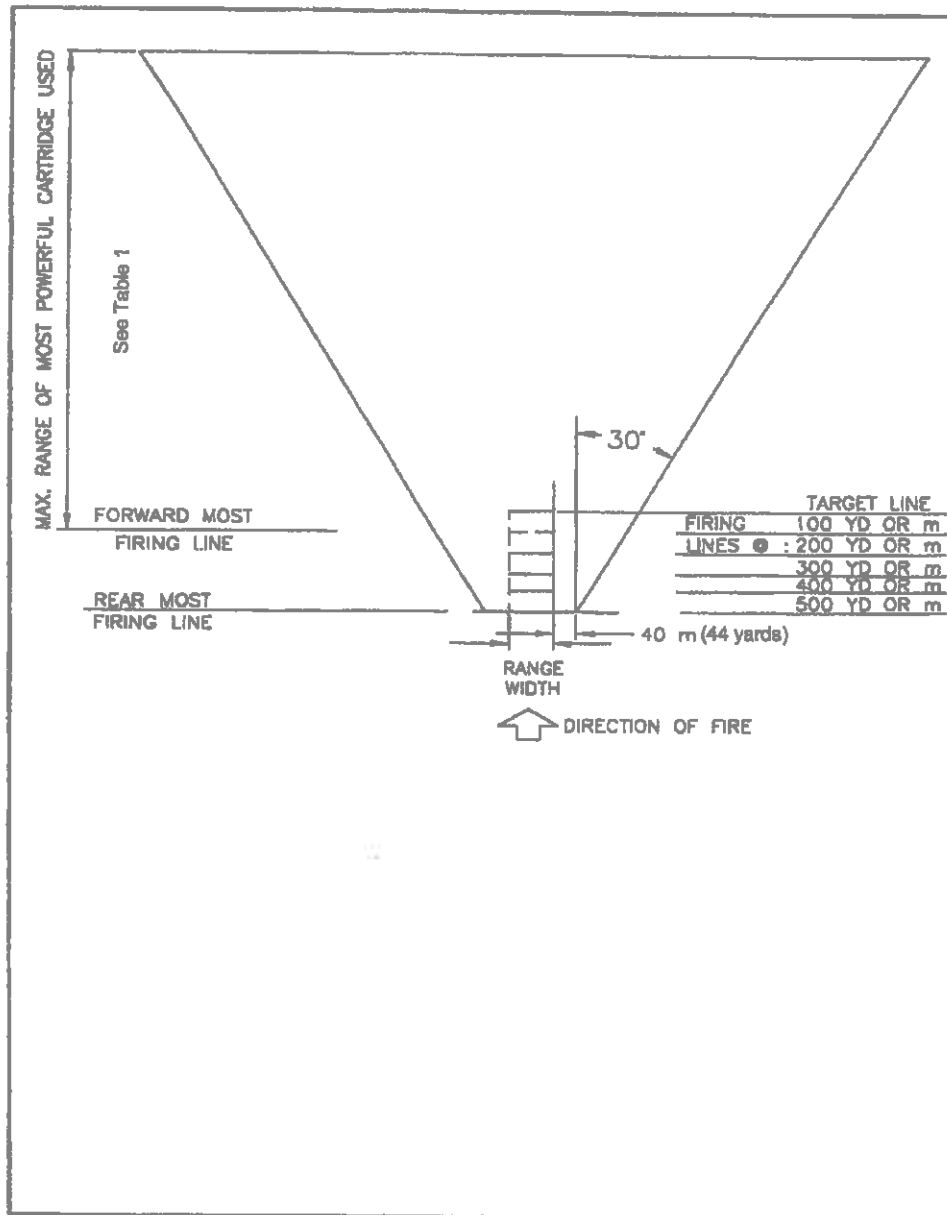

Figure 3
Surface Danger Zone for Small Arms Firing
At Fixed Ground Targets with Rocky Soil
Or Targets Causing Ricochet

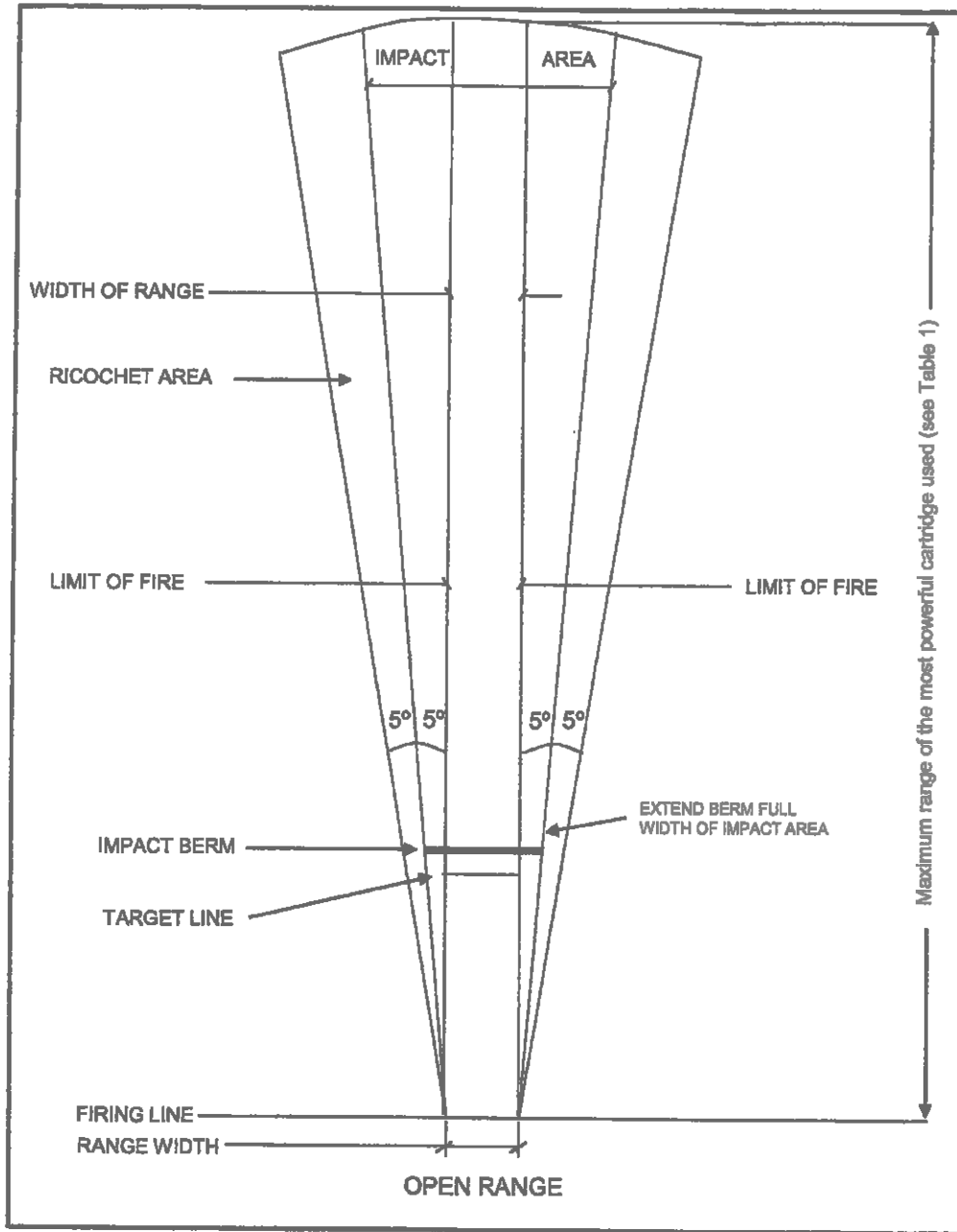

Figure 5
Surface Danger Zone with Impact Berm
for Small Arms Firing at Fixed Ground Targets

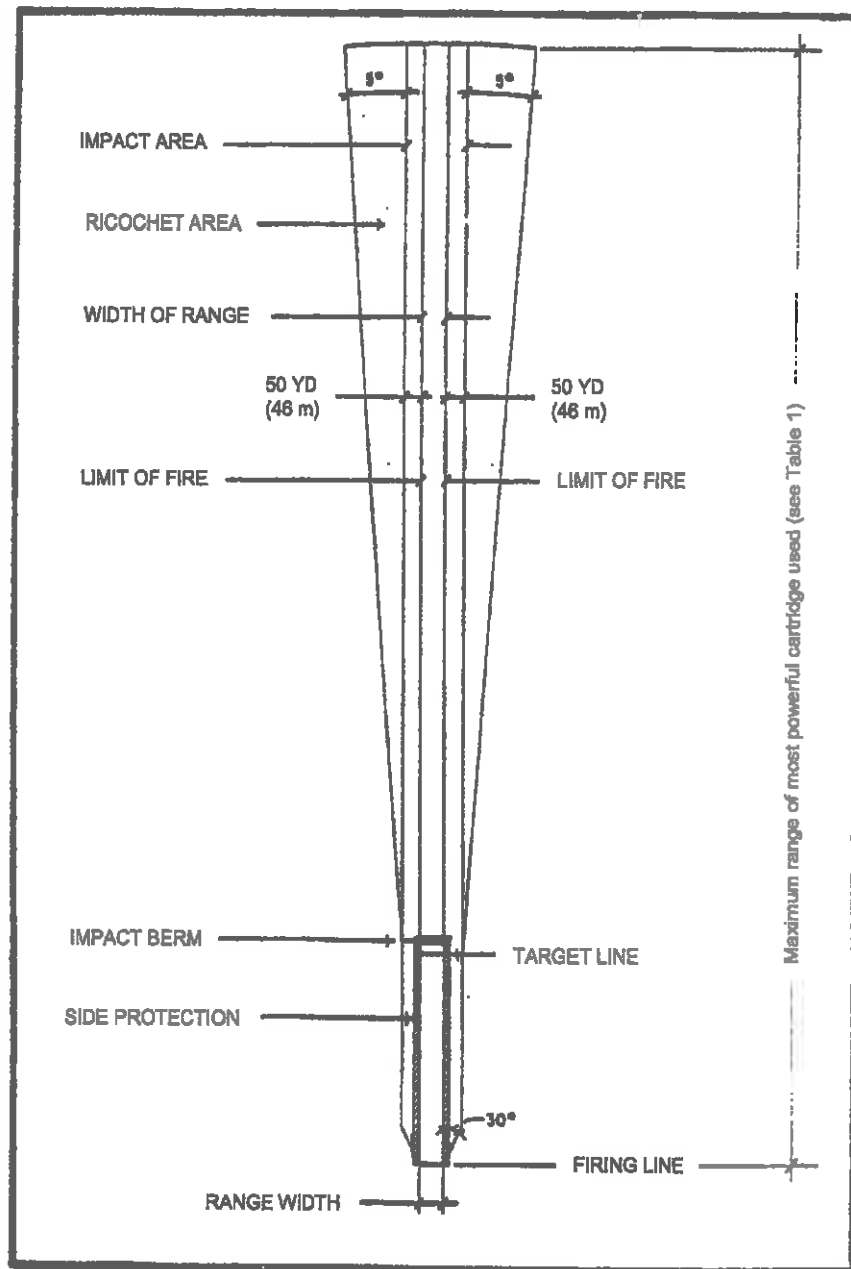

Figure 6
Open Range with Impact Berm and Side
Protection Surface Danger Zone for Small Arms
Firing at Fixed Ground Targets

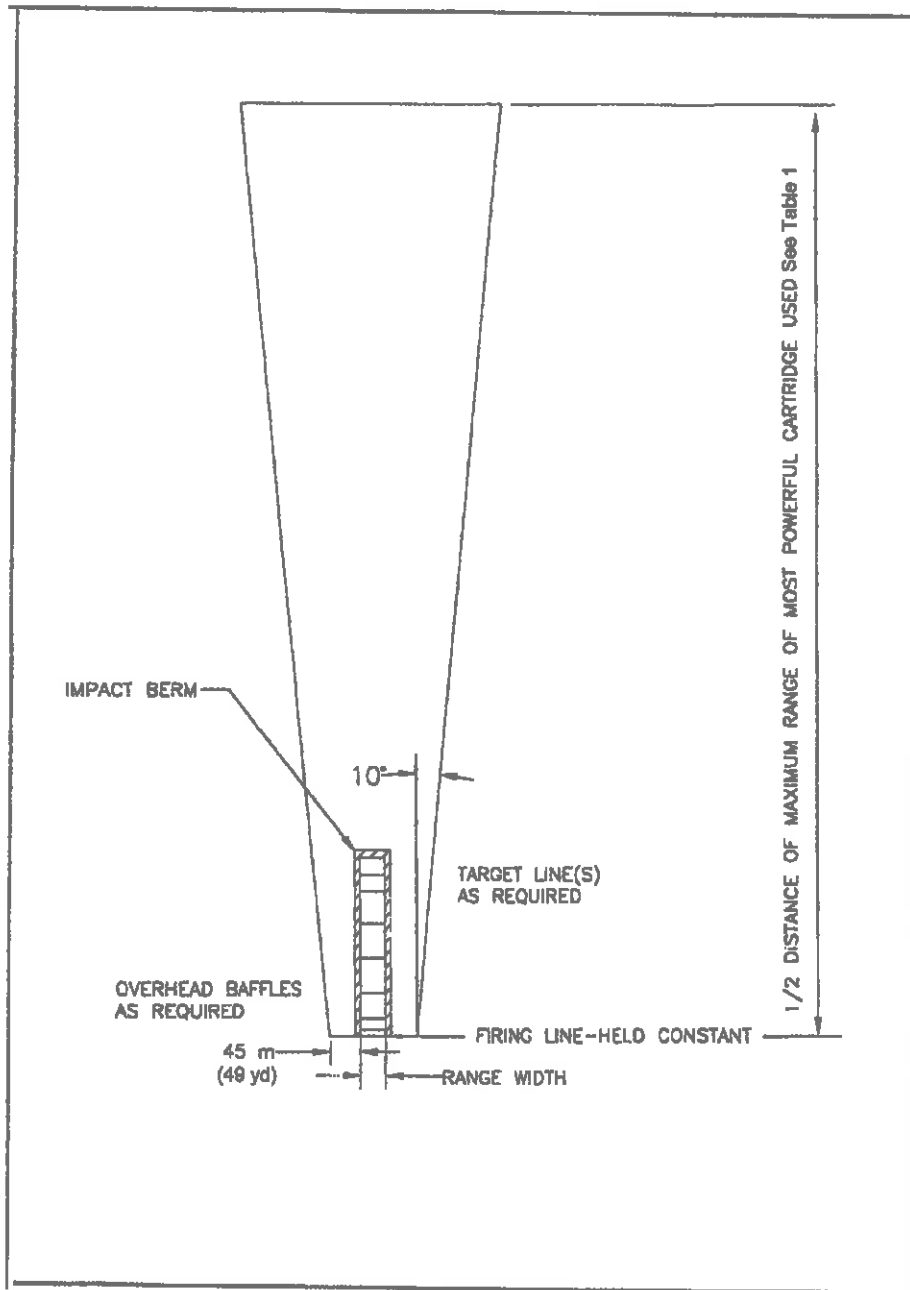

Figure 7
Surface Danger Zone for Partially Baffled Range
(Small Arms Firing at Fixed Ground Targets)

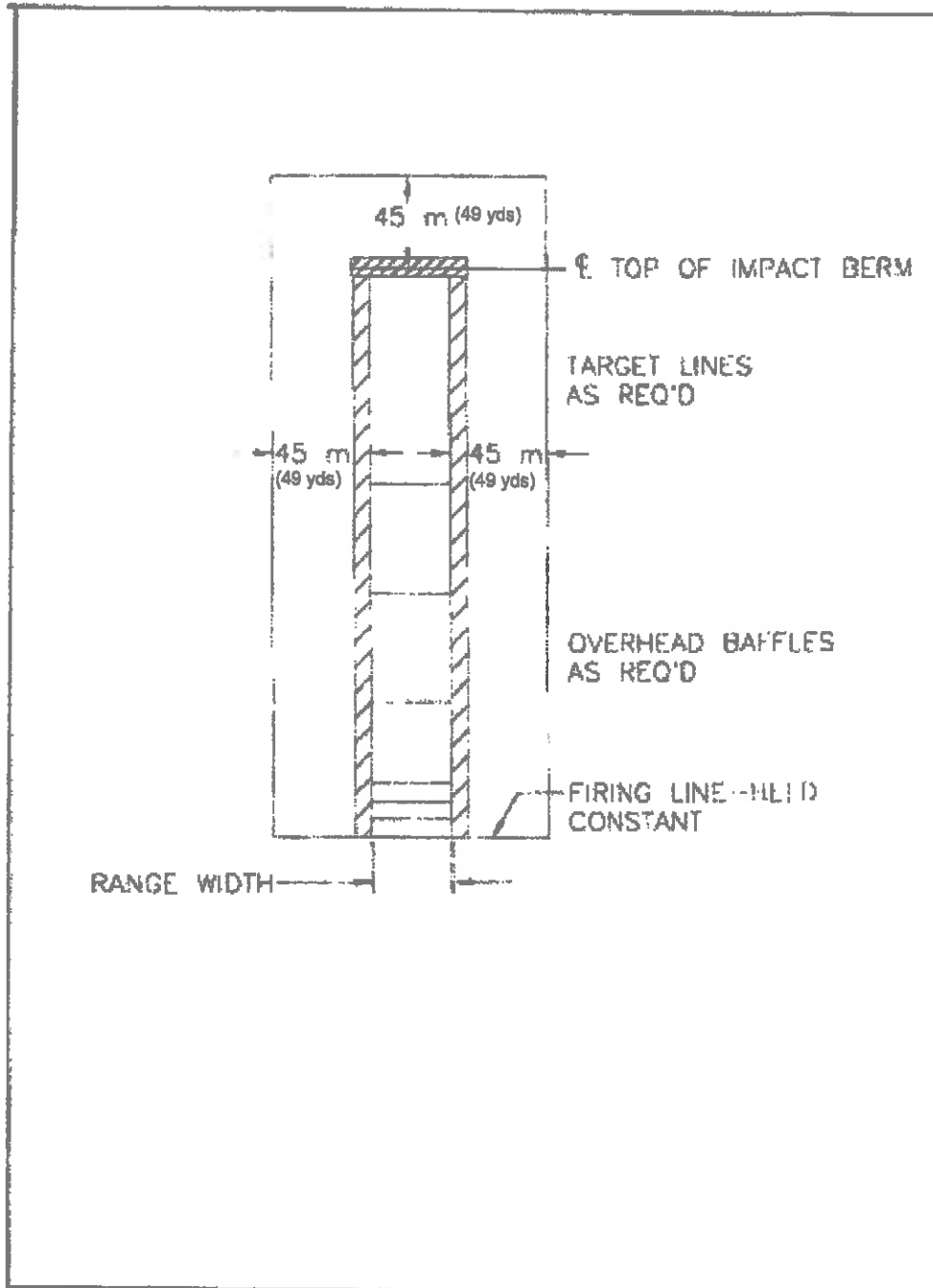

Figure 8
Surface Danger Zone for Fully Baffled Range
(Small Arms Firing at Fixed Ground Targets)

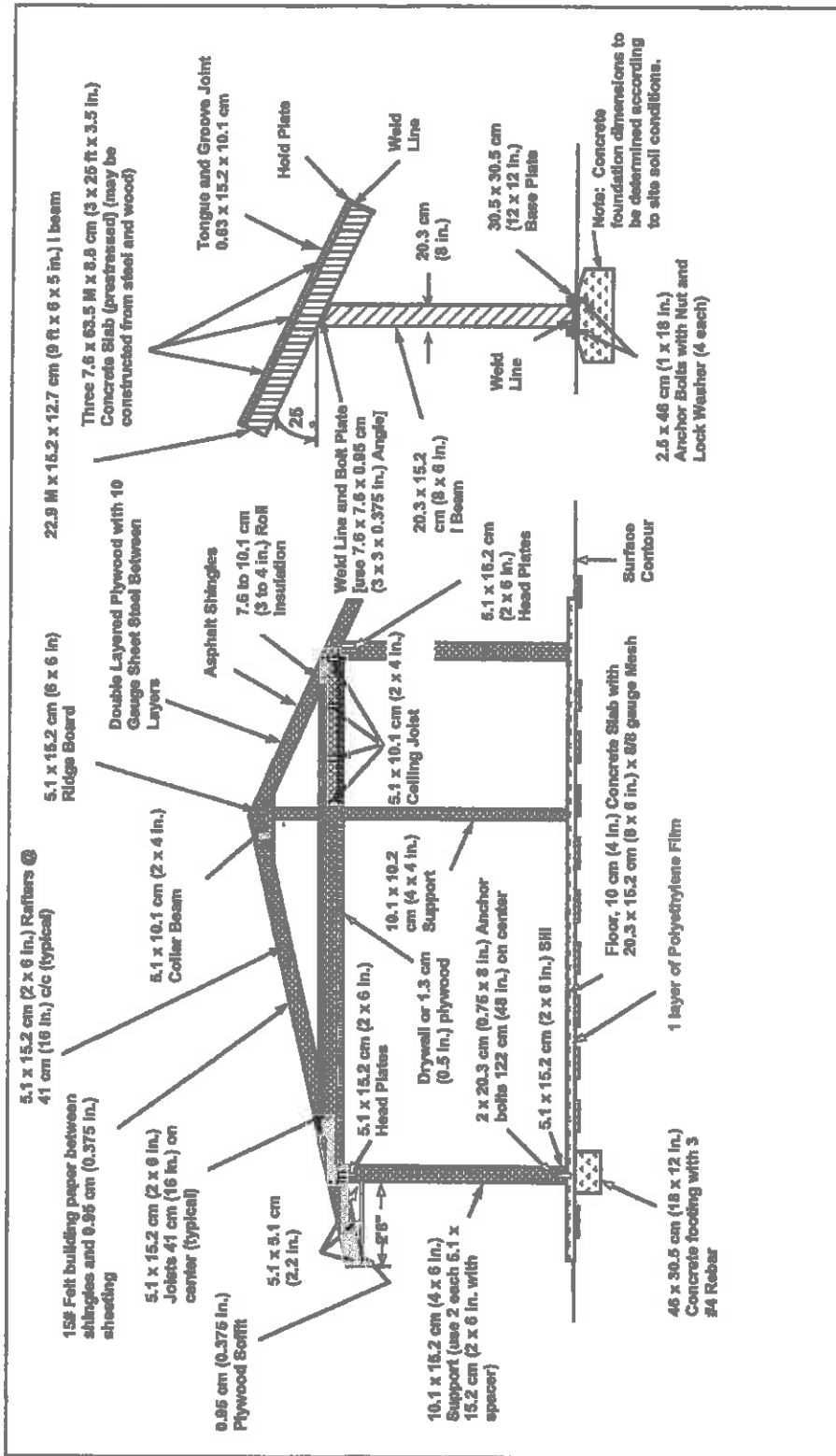

Figure 9
Ballistic Overhead Canopy

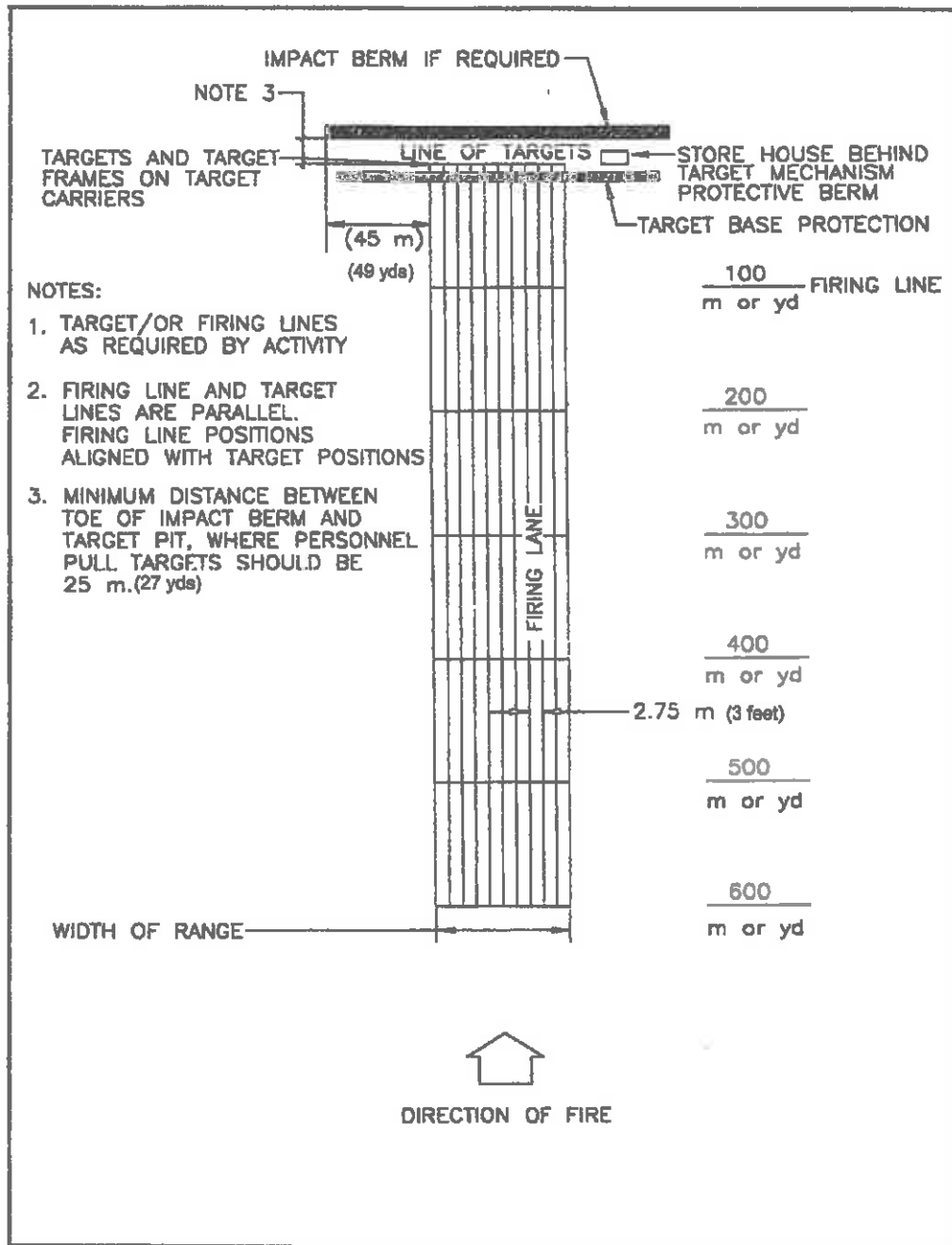

Figure 10
Outdoor Rifle Range Layout

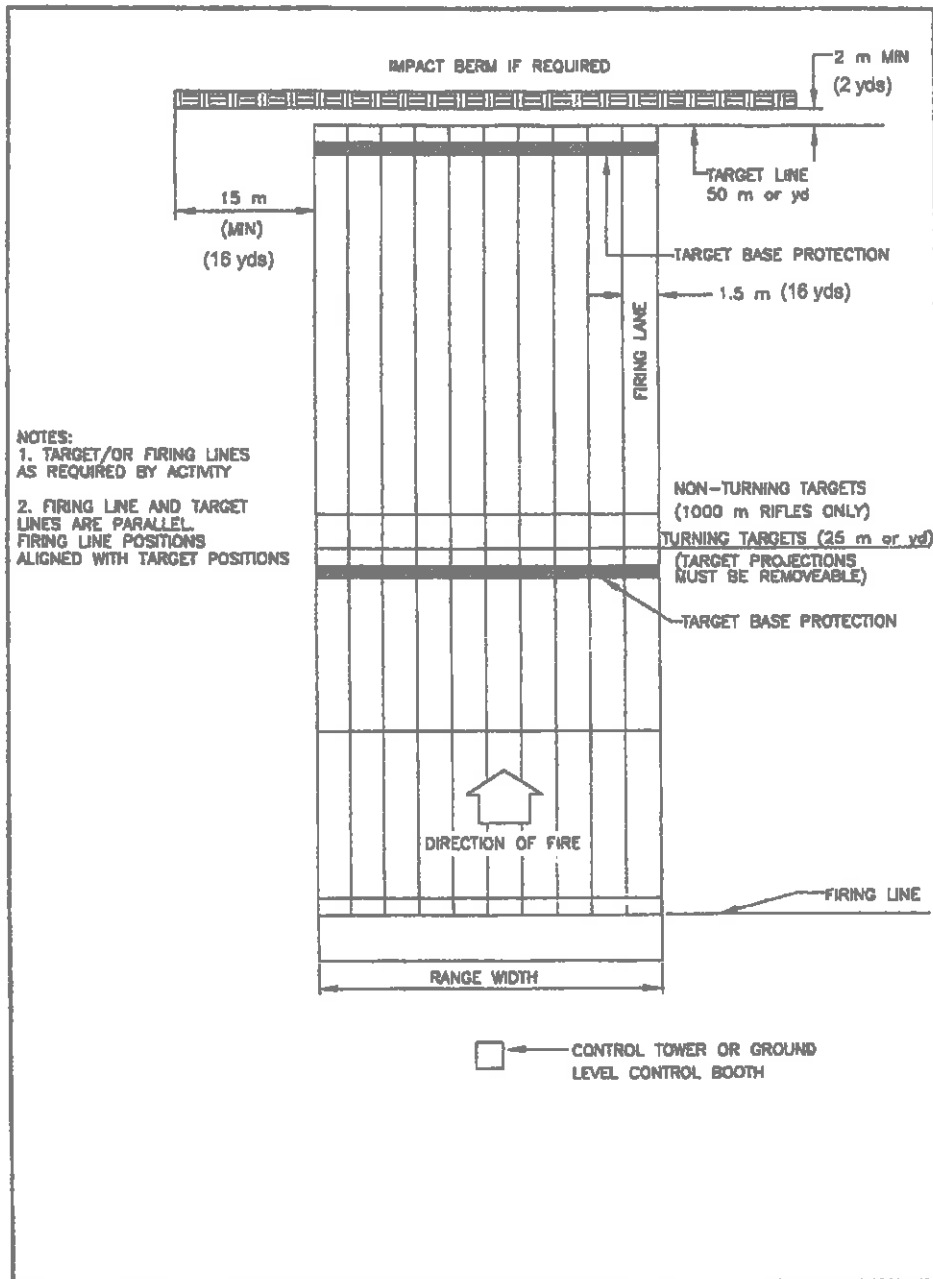

Figure 11
Pistol Range Layout

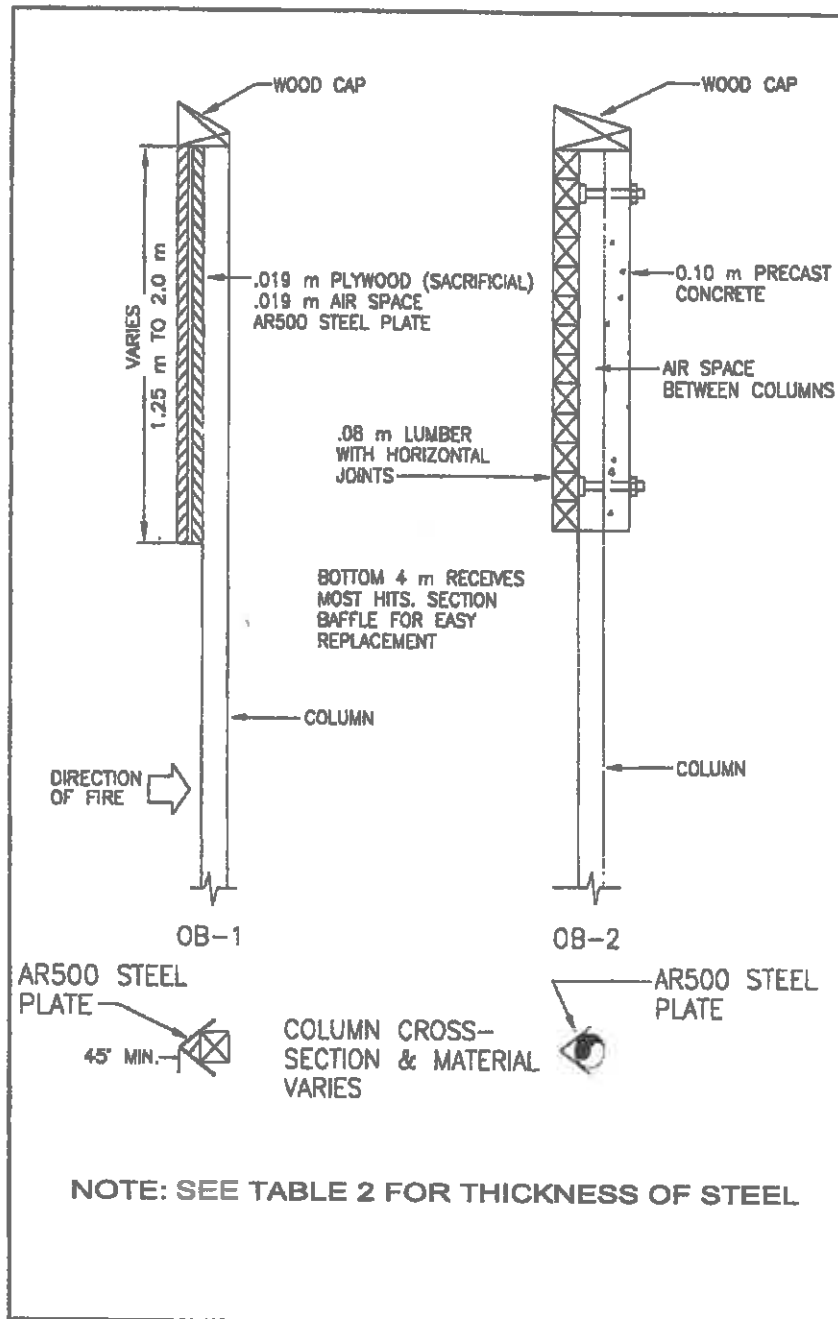

Figure 12
Ballistic Material

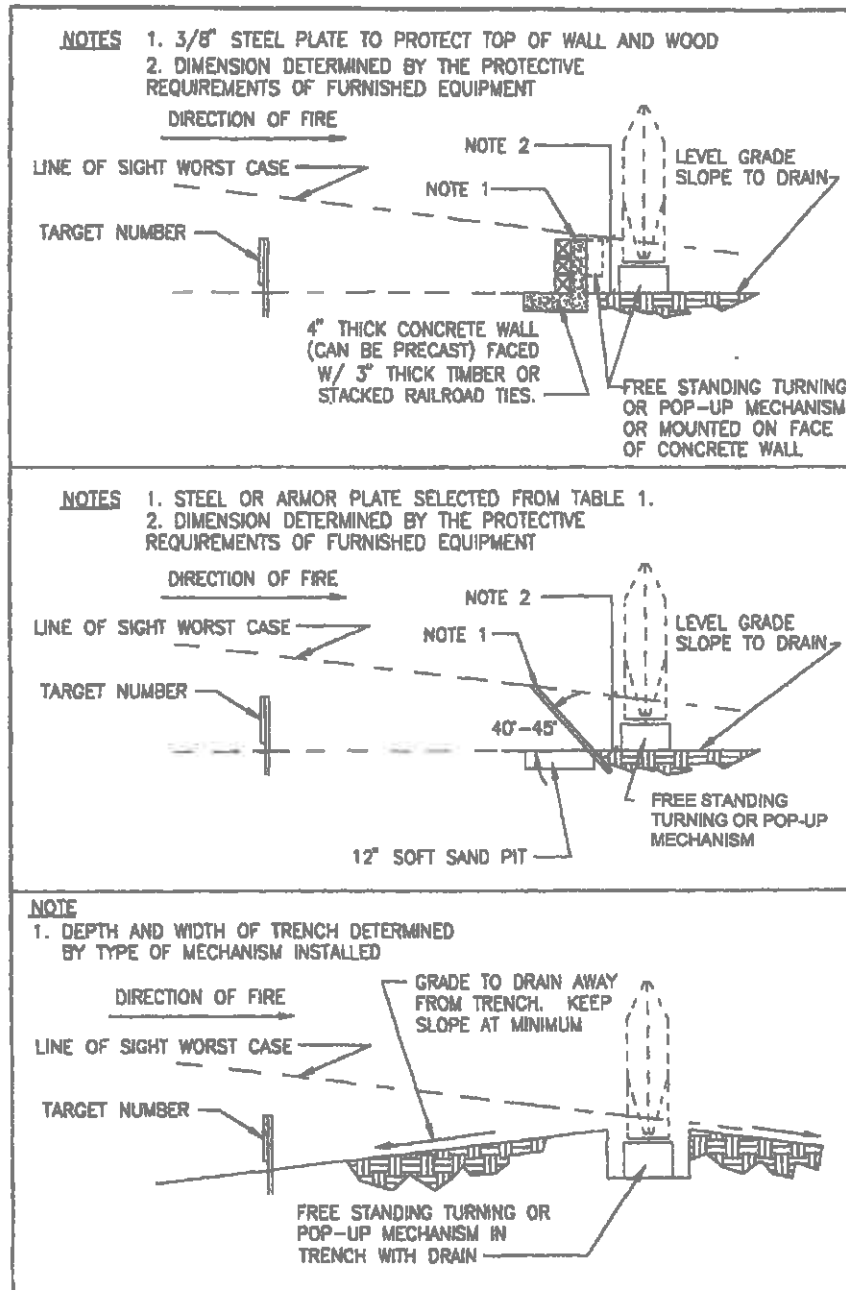

Figure 13
Ballistic Protection of Target Mechanism

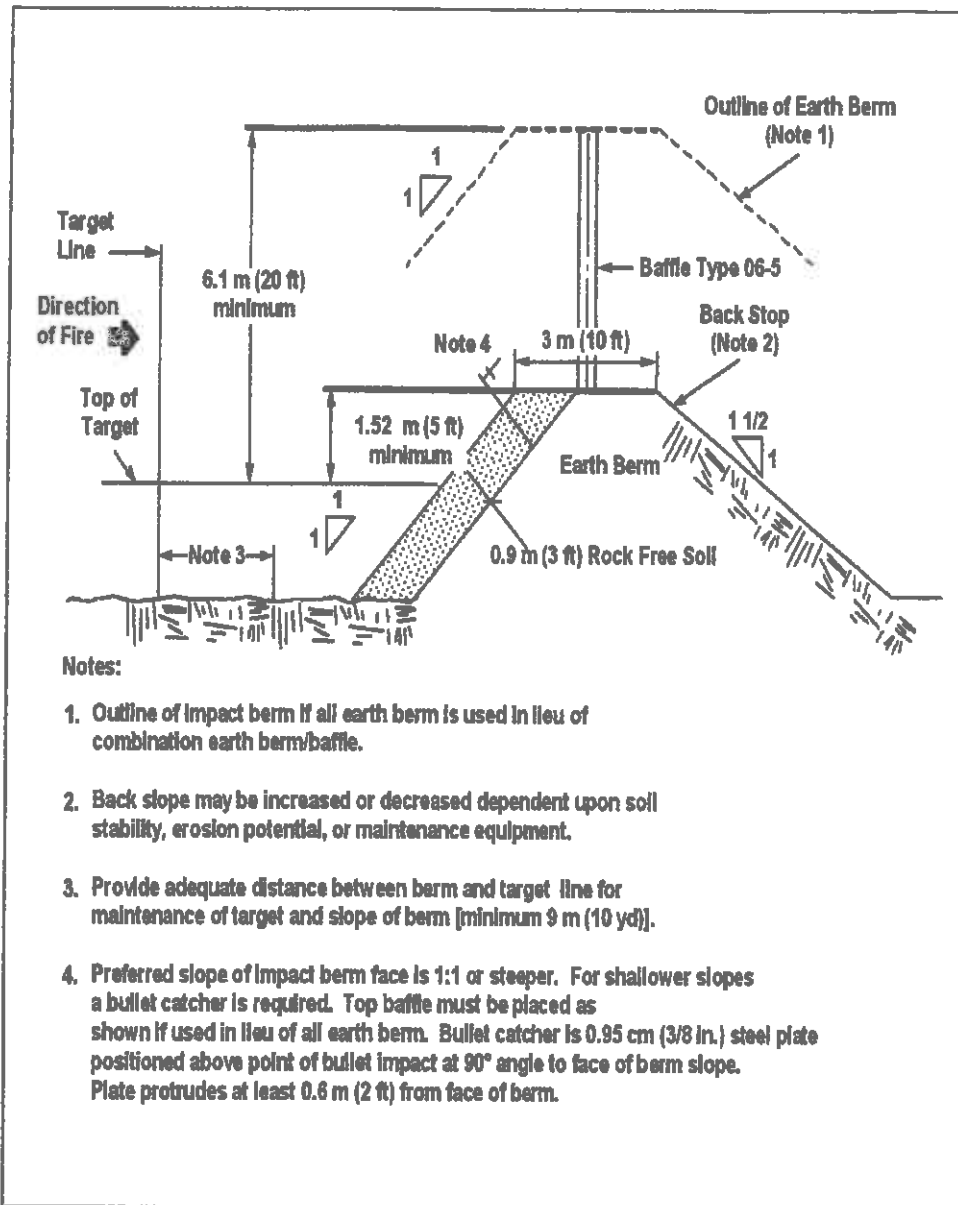

Figure 14
Impact Berm for Open and
Partially Baffled Ranges

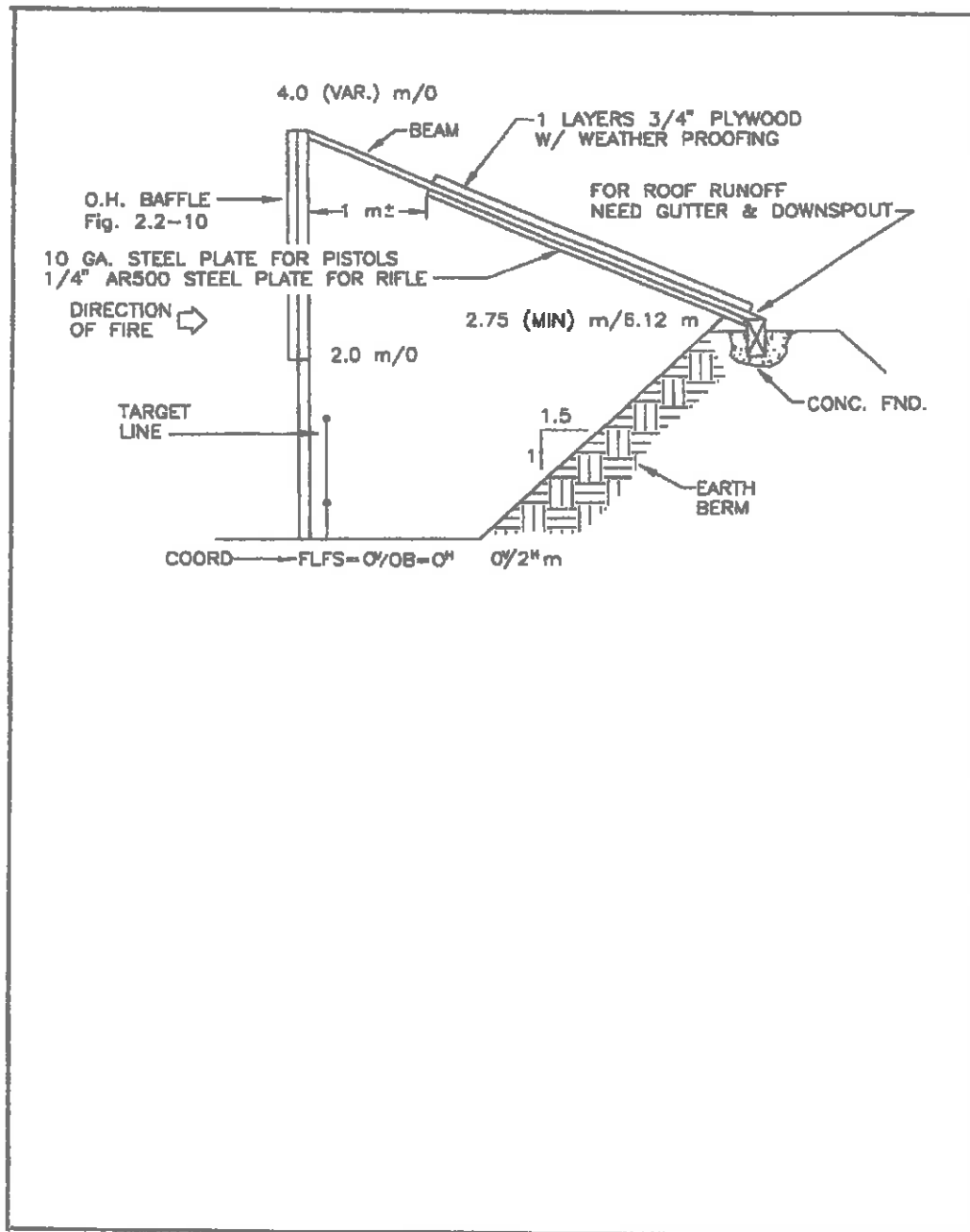

Figure 15
Outdoor Baffled Bullet Stop

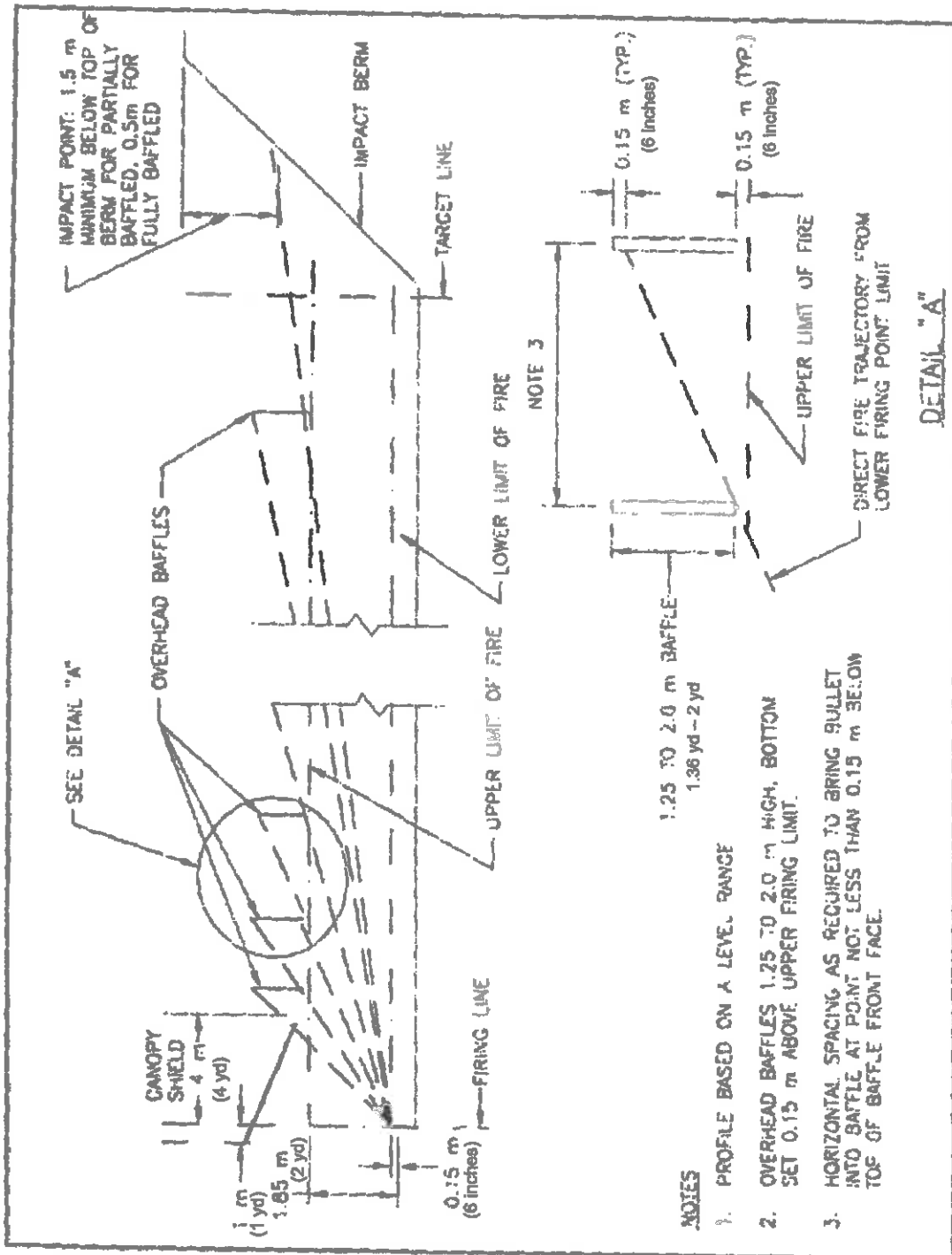

Figure 16
Baffled Range Profile

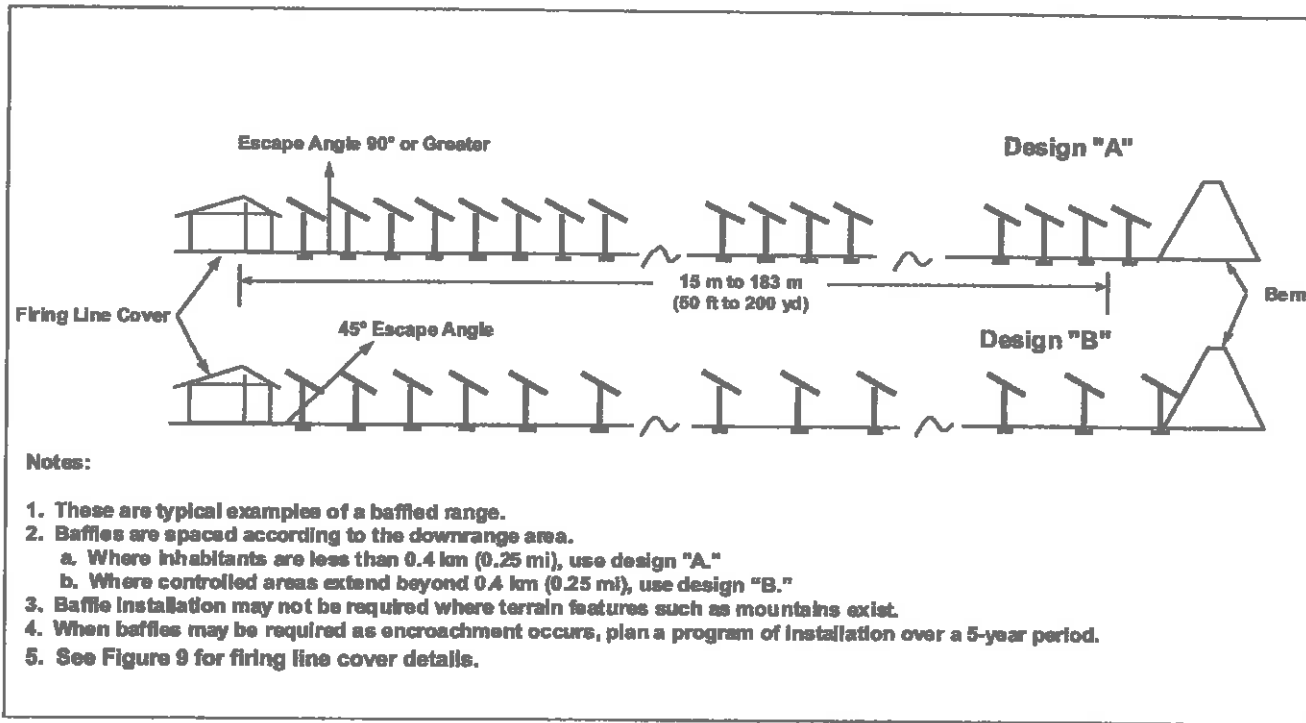

Figure 17
Baffle System Geometry

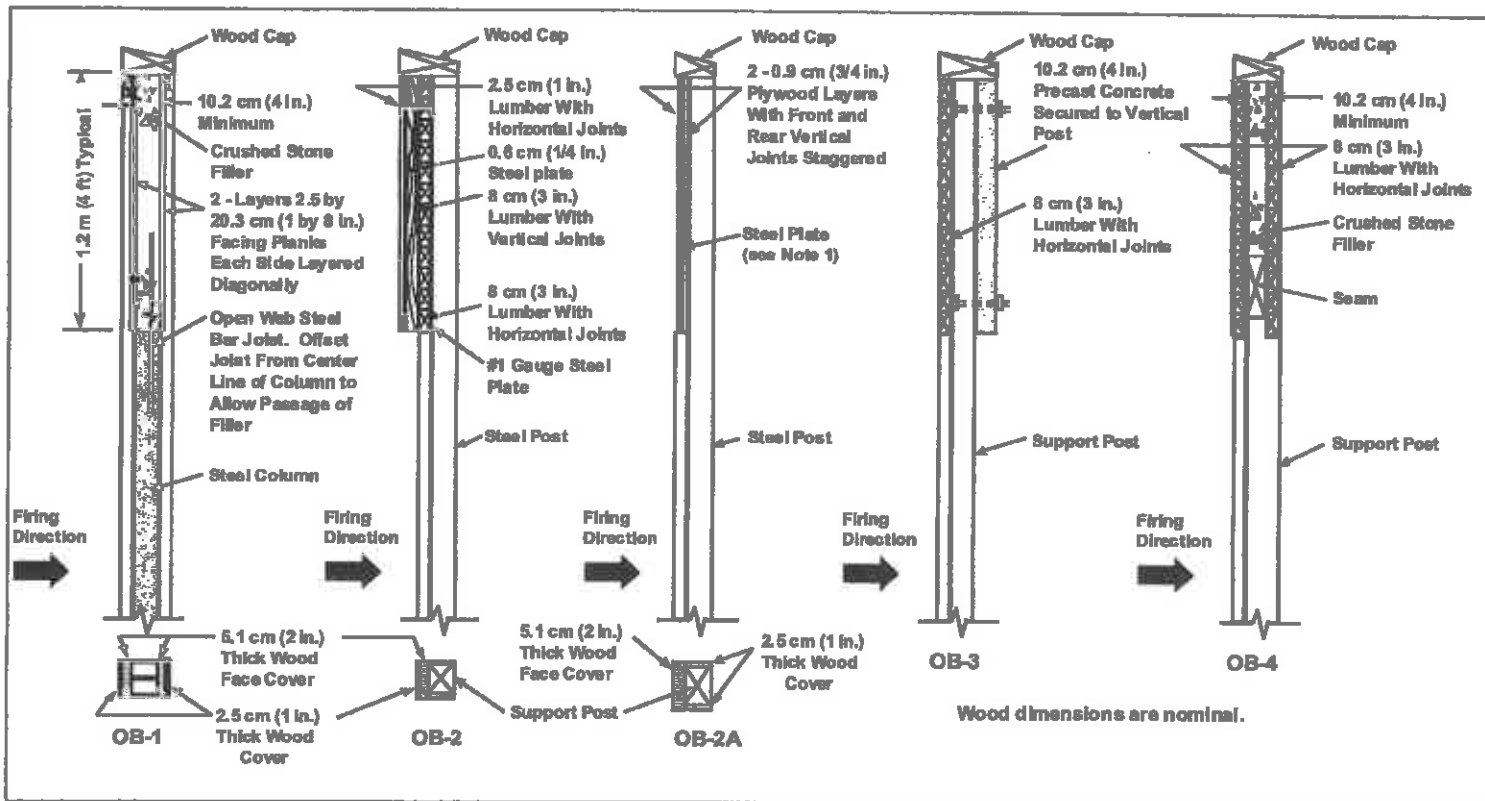

Figure 18
Overhead Baffle Ballistic Designs

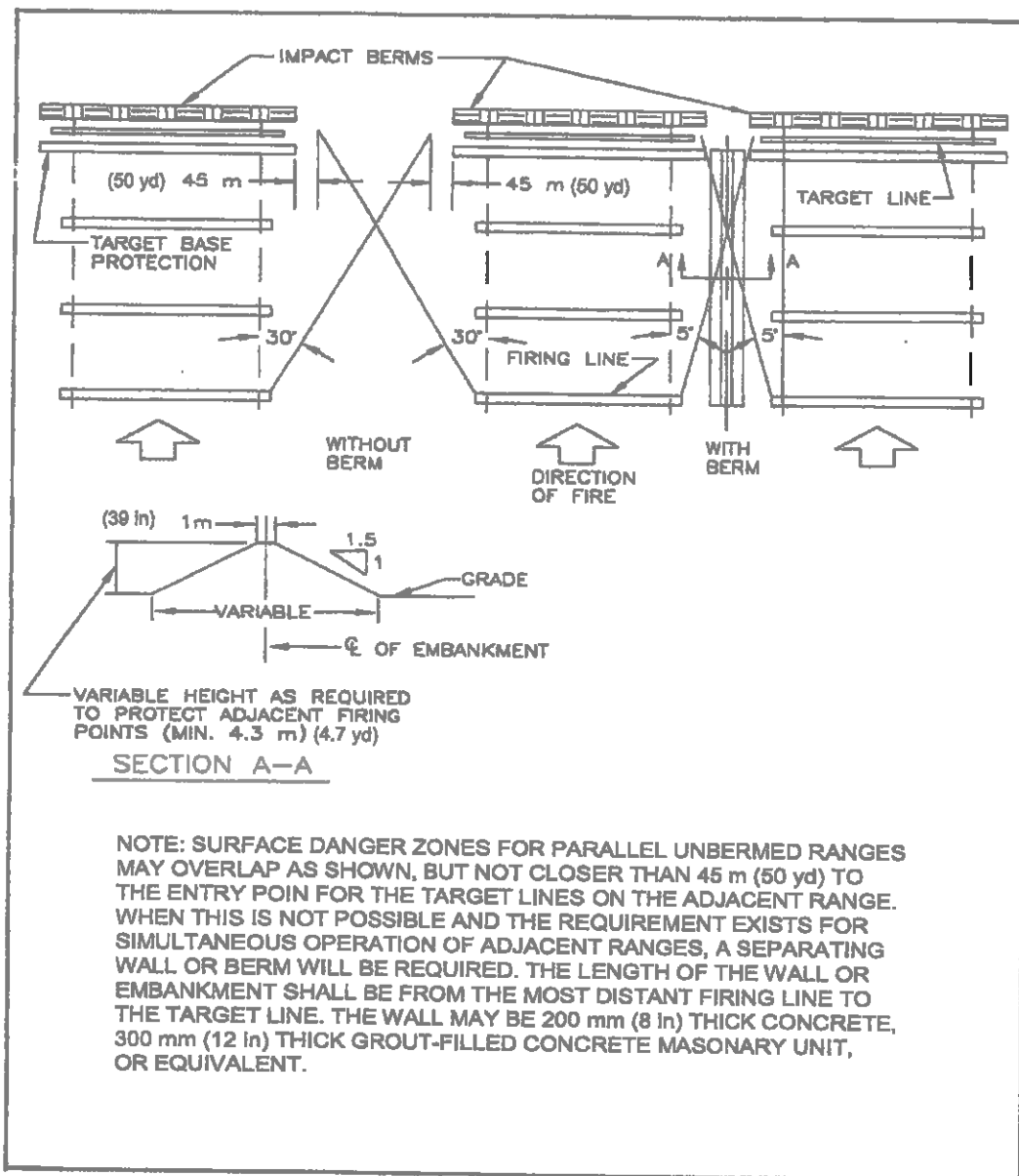

Figure 19
Parallel Ranges

8/10/18

PRISCILLA,

HERE IS A COPY OF THE LETTER
WE DISCUSSED WITH THE CHANGES MADE.
I HOPE YOU WILL BE ABLE TO GET
IT READ INTO THE RECORD ON 8/27/18,
I HAVE ALSO SENT THIS EXACT PACKET
TO MATT ASSELMAYER REQUESTING THAT
IT BE PUT IN THE FILE FOR THAT
MEETING.

THANK YOU

William A. [unclear]

SHOOTING INTO HIS HOUSE
VICTIM STATEMENT AND
POLICE REPORT

8/3/2018

To the Zoning Board of appeals of Kendall County Illinois.

Members,

It is a fact that in any activity, or endeavor that people participate in, invariably, accidents happen. With the participants safety in mind, this is one of the reasons we impose rules governing these activities. I would call your attention to safety rules in the workplace, driving, or even rules we set in our homes for the safety of our families. The idea of eliminating or reducing the safety rules in the few areas mentioned would create a situation where accidents happen more often. I cannot imagine that reducing the rules for driving alone, would mean less accidents, it would mean more.

That being said, I would also say that an accident with a bullet is one of the most devastating, and not just for the family where life was taken, but also for the shooter where the accident of a stray bullet originated. The loss of an innocent child doing their homework at the kitchen table is incomprehensible to anyone who has not experienced this, and it happens.

From the shooters side, I cannot imagine how it would feel to that person knowing that they took an innocent life. For the shooters family, they now have to live with the fact that one of their members is in jail, for a prescribed amount of years, due to an "accident". Or all the legal wrangling this family will incur now

with all the lawsuits that will happen.

I call this boards attention to these facts because in November of 2016 my house, my living space, was the recipient of one of these "accidents ". A bullet came through my rear thermopane window, crossed my family room, then went through the opposite wall, and landed on my living room floor. Fortunately, for all of us, we were not home at the time, but that bullet had enough energy to kill. Where the bullet originated from, I do not know. I do know that there is "ungoverned" outdoor practice shooting in my immediate area. I have included a copy of the Police report that was made at the time of the shooting.

In front of this board now is a proposal to reduce the safety rules governing the use of outdoor shooting ranges. As a resident of Kendall County, and the recipient of the accident stated above, I ask that this board please not change the rules now in place designed to protect your community. A reduction or removal of these safety rules would create a more dangerous situation as opposed to a safer one. I humbly ask that this Committee follow the recommendation of the Planning Commission that voted 8 to 0 to keep the rules as they stand. This is better for your county, community, and it's residents.

Thank you.

William Sales

8478 old ridge rd.

Plainfield Illinois.



Kendall County Sheriff's Office Detail



Print Date/Time: 11/09/2016 10:33
 Login ID: dfarren
 Case Number: 2016-00003558

KENDALL COUNTY SHERIFF'S OFFICE
 ORI Number: IL0470000

Case Details:

Case Number: 2016-00003558	Incident Type: 0470 - RECKLESS CONDUCT		
Location: 8478 OLD RIDGE RD PLAINFIELD, IL 60544	Occured From: 11/04/2016 18:00	Occured Thru: 11/08/2016 18:00	Reported Date: 11/08/2016 18:55 Tuesday
Reporting Officer ID: TJ010214- JOHNSON	Status: 1 - OPEN	Status Date: 11/09/2016	

Offenses

No.	Group/ORI	Crime Code	Statute	Description	Counts
1	State	0470	720 ILCS 5/12-5(a)	RECKLESS CONDUCT	1
Offense # 1					
Group/ORI:	State	Crime Code: 0470	Statute: 720 ILCS 5/12-5(a)	Counts: 1	Attempt/ Commit Code: COMMITTE D
Description:	RECKLESS CONDUCT			Offense Date: 11/08/2016	
NCIC Code:	0470 - RECKLESS CONDUCT	Scene Code:	20 - RESIDENCE/HOME		
IBR Seq. No:	1				

Subjects

Type	No.	Name	Address	Phone	Race	Sex	DOB/Age
SUSPECT	1	UNKNOWN, USE FOR ALL CASES					
VICTIM	2	SALES, MARIA ISABEL	8478 RIDGE RD PLAINFIELD, IL 60544	[REDACTED]			
VICTIM	11	SALES, WILLIAM ALAN	8478 RIDGE RD PLAINFIELD, IL 60544				

Kendall County Sheriff's Office

Detail

Print Date/Time: 11/09/2016 10:33
 Login ID: dfarren
 Case Number: 2016-00003558

KENDALL COUNTY SHERIFF'S OFFICE
 ORI Number: IL0470000

Subject # 1-SUSPECT
Primary: No **SUSPECT Type:** SUSPECT
Name: UNKNOWN, USE FOR ALL CASES

Related Offenses

Group/ORI	Crime Code	Statute	Description
State	0470	720 ILCS 5/12-5(a)	RECKLESS CONDUCT

Subject # 2-VICTIM

Primary: No **VICTIM Type:** INDIVIDUAL
Name: SALES, MARIA ISABEL **Race:** [REDACTED] **Sex:** [REDACTED] **DOB:** [REDACTED]
Address: 8478 RIDGE RD **Height:** [REDACTED] **Weight:** [REDACTED]
 PLAINFIELD IL 60544 **Eyes:** [REDACTED] **Hair:** [REDACTED]
Primary Phone: [REDACTED] **DVL #:** [REDACTED] **State:** [REDACTED]

Resident Status: RESIDENT

Related Offenses

Group/ORI	Crime Code	Statute	Description
State	0470	720 ILCS 5/12-5(a)	RECKLESS CONDUCT

Subject # 1-VICTIM

Primary: No **VICTIM Type:** INDIVIDUAL
Name: SALES, WILLIAM [REDACTED] **Race:** [REDACTED] **Sex:** [REDACTED]
Address: 8478 RIDGE RD **Height:** [REDACTED] **Weight:** [REDACTED]
 PLAINFIELD IL 60544 **Eyes:** [REDACTED] **Hair:** [REDACTED]
Primary Phone: [REDACTED] **DVL #:** [REDACTED] **State:** [REDACTED]

Resident Status: RESIDENT

Related Offenses

Group/ORI	Crime Code	Statute	Description
State	0470	720 ILCS 5/12-5(a)	RECKLESS CONDUCT

Arrests

Arrest No.	Name	Address	Date/Time	Type	Age
------------	------	---------	-----------	------	-----

Property

Date	Code	Type	Make	Model	Description	Tag No.	Item No.
11/09/2016	DESTROYED/ALPA POLYMER/RED WAND/PLATE	WOODS			APPROXIMATELY 4 TALL GLASS DOUBLE PANE WINDOW DEFORMED COPPER TACKETED BULLET		

Kendall County Sheriff's Office Narrative
Case #2016-3558
DEPUTY T. JOHNSON
11/08/2016

On 11/08/16 at approximately 1856 hours I, DEPUTY JOHNSON #109 and DEPUTY DECAMP #76 were dispatched to 8478 Old Ridge Road, Plainfield IL 60544, as the caller called to report that when they returned home from a short vacation over the weekend they discovered a bullet hole in their glass window in their living room and then went into the wall of the living room.

Upon our arrival we met with WILLIAM ALAN SALES, DOB [REDACTED] and his wife MARIA ISABEL SALES, DOB [REDACTED]. WILLIAM and MARIA stated that they left to go to Wisconsin to visit their son on Friday, 11/04/16 at approximately 1800 hours and were gone until they returned home this evening at approximately 1800 hours. WILLIAM stated that at first he did not notice the hole in the window, however, he started to discover pieces of glass on the carpet and near the couch. WILLIAM said that once he started locating glass he then took a look around and then discovered the hole in the upper portion of the living room window which faces to the east. WILLIAM then stated MARIA began to look around as well and then located a small hole in the wall of the living room in the drywall. I asked WILLIAM if there are neighbors of his that shoot in the backyards and he stated that none of his immediate neighbors do, however he will hear what sounded like gunshot off in the far distance to the east and also to the west.

DEPUTY DECAMP then began to take photos of the window and the wall while I attempted to make contact with the neighbor to the north of WILLIAM and MARIA, however no one was home at this time or answered the door. While taking the photos DEPUTY DECAMP found the actual projectile that had come through the walls into the other room and came to rest behind a china hutch and eventually came to rest on the floor. DEPUTY DECAMP also recovered the projectile which was later placed into evidence. See DEPUTY DECAMP's supplement report for details on the photographs and processing of the evidence.

I then explained to WILLIAM that he might want to take a walk around his house in the morning, during the daylight, where visibility would be better to see if there was any other possible damage that was caused to his house. I explained to WILLIAM that it appears this was a random isolated incident and that there is no further evidence suggesting that his house was being targeted for any reason. To the east of WILLIAM's house is Ridge Road at the intersection of Route 126. From my past experience I have known that occasionally people traveling down Route 126 have discharged firearms while driving along the road and it appears that this may be a unaccounted for projectile that someone may have been firing from a moving vehicle.

I then gave WILLIAM a Kendall County Sheriff's Office business card with the report number and suggested to him that if he finds any other damage or similar possible bullet holes in his home, to contact the non emergency line and report the other damage that he found.

Nothing further at this time.

Submitted by:	[REDACTED]	#101	200 1/19/10	100-0553-209
Approved by:	[REDACTED]	#31	200 2/19/10	100-062-209



Kendall County Sheriff's Office

Summary



Print Date/Time: 11/09/2016 10:34
 Login ID: dfarren
 Case Number: 2016-00003558

KENDALL COUNTY SHERIFF'S OFFICE
 ORI Number: IL0470000

Case

Case Number: 2016-00003558	Incident Type: 0470 - RECKLESS CONDUCT
Location: ██████ OLD RIDGE RD PLAINFIELD, IL 60544	Occurred From: 11/04/2016 18:00
Reporting Officer ID: TJO10214 - JOHNSON	Occurred Thru: 11/08/2016 18:00
	Disposition:
	Disposition Date:
	Reported Date: 11/08/2016 18:56 Tuesday

Offenses

No.	Group/ORI	Crime Code	Statute	Description	Counts
1	State	0470	720 ILCS 5/12-5(a)	RECKLESS CONDUCT	1

Subjects

Type	No.	Name	Address	Phone	Race	Sex	DOB/Age
SUSPECT	1	UNKNOWN, USE FOR ALL CASES					
VICTIM	1	SALES, WILLIAM ALAN	█████ RIDGE RD PLAINFIELD, IL 60544				
VICTIM	2	SALES, MARIA ISABEL	█████ RIDGE RD PLAINFIELD, IL 60544				

Arrests

Arrest No.	Name	Address	Date/Time	Type	Age

Property

Date	Code	Type	Make	Model	Description	Tag No.	Item No.
11/08/2016	SAFEKEEPING	PHOTOGRAPHS			VERBATIM CD-R W DIGITAL PHOTOGRAPHS		
11/08/2016	DESTROYED/DAMAGED/VANDALIZED	HOUSEHOLD GOODS			APPROXIMATEY 4' TALL GLASS DOUBLE PANE WINDOW		
11/09/2016	EVIDENCE	AMMUNITION			DEFORMED COPPER JACKETED BULLET	17725	1

Chain of Custody

Date	Transaction	From	From Role	To	To Role
11/09/2016 08:46	Type: Intake	TD091597-TIMOTHY DECAMP	OFFICER	JO050216-JENNIFER OSTROM	PROPERTY OFFICER
	Code: EVIDENCE BROUGHT IN BY OFFICER				
	Tag Number: 17725				
	Remarks:				

Vehicles

Vehicle No.	Make	Model	Year	Color	License

Kendall County Sheriff's Office

Summary



Print Date/Time: 11/04/2016 10:34
Login ID: dfarren
Case Number: 2016-00003556

KENDALL COUNTY SHERIFF'S OFFICE
ORI Number: IL0470000

No.	Role	Vehicle Type	Year	Make	Model	Color	License Plate	State
-----	------	--------------	------	------	-------	-------	---------------	-------

Kendall County Sheriff's Office Narrative
Case #2016-3558A
DEPUTY T. DECAMP
11/08/2016

On 11/08/16 at approximately 1900 hours, I, DEPUTY DECAMP #76 responded to 8478 Old Ridge Road, Plainfield to assist DEPUTY JOHNSON #109 for report of a possible criminal damage to property where the complainant was relating that upon his return from his vacation he had noticed a broken bay window and what appeared to be a stray bullet hole in the wall inside of his residence.

Upon arrival DEPUTY JOHNSON and I met with the homeowner and victim, later identified as WILLIAM A. SALES, DOB [REDACTED] who related that upon return from being in Wisconsin with his wife, he had noticed some small shards of broken glass on his couch and upon inspection of his living room, observed what appeared to be a baseball size hole in the top of one of his bay windows on the east side of the house and a short time later directly behind the couch on the west wall in the same path of the broken window he noticed a small hole that he believed to be a bullet hole in his drywall. Upon inspection of the exterior of the residence, we could observe a large baseball size circular hole in the top part of the 6 foot tall bay window and upon further inspection of the interior of the residence in the living room, just above the couch resting against the west wall what appeared to be a small half in wide by quarter inch tall circular nature hole. We then went to the sitting room on the other side of the living room wall where we located an exit hole directly behind a corner curio cabinet location which appeared to have burst out drywall and what appeared to be a small impact point on the back of the fiber board of the curio cabinet. WILLIAM said he could not locate the projectile but still believed it to be a bullet. Upon inspection around to the south side of the curio cabinet, between the cabinet and the wall in a three inch gap, I was able to locate a small copper in color projectile resting approximately two feet away from the leg that supported the curio cabinet in between the cabinet and the south wall.

I assisted DEPUTY JOHNSON #109 in performing evidence technician duties photographing the exterior of the residence, window, shards of glass left by the broken window, both on the exterior of the residence on the bottom of the window pane and bushes outside, as well as broken glass on the blinds from the top of the hole that was located down to the base of the windowsill on the interior of the residence. I photographed the location of the hole in the wall left by the projectile which appeared to be at head level if one was to be seated on the couch. I photographed the damage done by the exit of the projectile in the opposite room, opposite the entry hole in the living room and the location of the projectile as well. All photographs were taken with and without scale. I was then able to retrieve the small copper in color projectile, and in this deputies opinion it appeared to be a pistol caliber, possibly a 9mm or 40 caliber. Upon close inspection of the projectile, it appeared to be a full copper jacketed ball ammo round with no evidence of a hollow point in it and it appeared it was deformed as if it had ricocheted or bounced off a hard surface, possibly prior to entering the residence window and residence of [REDACTED] Old Ridge Road.

The projectile was recovered and upon my return to the Public Safety Center I put it into evidence as recovered property and possible evidence.

I downloaded all digital images taken with my camera to a verbatim CD-R disc which was released to Records for safekeeping.

Nothing further.

LOTT 11-14-16 drf

Submitted by	[REDACTED]	76	10/23/16 11:23:00
Approved	[REDACTED]	[REDACTED]	11/16 11:23:00 - 3/1/17

Kendall County Sheriff's Office - Record of Evidence/Property

01 2007

Type of Incident/Offense: RUCKI FSS CONDUCT Page: 1 of 1 Report Number: 2016-3558 Date: 11-08-16

Property Status: Evidence Seized Found Recovered Safekeeping

Location Property Discovered or Obtained

██████████ OLD RIDGE RD, PLAINFIELD

Item # Victim (Name: L,F,M) D.O.B. Phone Number
SALES, WILLIAM ALAN ██████████ ██████████

Address: ██████████ OLD RIDGE RD, PLAINFIELD State: IL Zip: 60544

Item # Property Owner (Name: L,F,M) D.O.B. Phone Number

Address: State: Zip:

Item # Property Owner (Name: L,F,M) D.O.B. Phone Number

Address: State: Zip:

Suspect Offender Male Female Race: Phone Number

Item # (Name: L,F,M) D.O.B. Phone Number

Address: State: Zip:

Suspect Offender Male Female Race: Phone Number

Item # (Name: L,F,M) D.O.B. Phone Number

Address: State: Zip:

** State Firearm Owner's ID # State of Birth Height Weight Recovery Address

Owner Notified Date/Time By Name/ID Number
 Yes No

Item #	Qty	Description (Make, Model, Color, Serial #, Marks, Etc.)
1	1	SEALED WHITE ENVELOPE CONTAINING
1A	1	DEFORMED COPPER JACKETED BULLET

Special Instructions: Section Marked ** Only need to complete this section when firearm(s) submitted
HOLD

I Certify That I Have Received The Items Listed Below From This Inventory:

Item #	Date	Property Released By	Reason For Change	Received By
1	11-08-16	T. DECAMP #76	TEMP EVIDENCE	

T. DECAMP #76
Reporting Officer (Print Name & Badge #)

Signature

Make Kendall Gun Ranges Safe Testimony ZBA Public Hearing 08/27/2018

I am Priscilla Gruber, a resident in this county over 40 years. I am asking my county to reject the current proposal 17-28 as written. It does not promote the welfare of the citizens of this county. I believe it reduces it.

According to published county documents the intention of the proposal was to address noise and safety issues and to tighten outdoor gun range restrictions. Last fall, references to the draft proposal at the time were made to "minimum forty (40) acres in size" and "one thousand five hundred feet (1500) feet from property lines". After much discussion between boards at the county, the Planning Building and Zoning Committee asked the "expert" they chose, a commercial gun range promoter, to largely rewrite the proposal.

The result is the current proposal that deletes any minimum acreage requirement allowing a gun range to be on any size lot. That is even worse than the currently in force rules that require 5 acres minimum.

The 1500 foot buffer zone is completely gone. No buffer at all is even worse than the current regulations that require "at least 1000 feet from existing dwellings and property lines of schools, daycares, places of worship and airstrips." How is a 7 day per week, many hours per day, for profit outdoor gun range desirable right next to a church or school?

It specifically exempts Forest Preserve land from any requirements. That's a lot of land in our beautiful county. It drops the requirement for a lockable gate. Does that make sense?

It downgrades the qualifications for the range supervisor from "State recognized, nationally recognized or NRA Certified range supervisor" to a person "knowledgeable of the type of shooting being supervised". Almost any shooter qualifies under that standard.

These proposed changes do not carry out the original intentions to address noise and safety issues, tighten restrictions or promote the welfare of the county citizens.

The Committee defends these changes by saying repeatedly that they want to decide these things "on a case to case basis" That means no one knows what the rules will be for any piece of land at any time in the future. It all depends on who is in power at the time. Elected officials change, at least in some elections, and the same people in office can change their opinions over time or when different people present their projects to approve. This is inviting unpredictability, inconsistency and favors to be considered. That is government by men (or people) not government by the Rule of Law.

Respect for the Rule of Law, including the equal application of the laws to all citizens, and over time, in other words consistency and predictability, is bedrock in our Constitution. It is what makes us different from Kingdoms and dictatorships. We need this here in Kendall County too. We ask our County Board to do the job we elected them to do, write up the regulations now so we know what they are; don't leave them to decide each time somebody asks on "a case by case basis".

Look how many people are here concerned about this. I ask you to reject this inadequate proposal so our county can start over to truly promote the welfare of all county citizens.

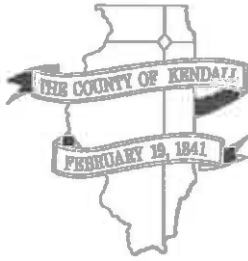

DEPARTMENT OF PLANNING, BUILDING & ZONING

111 West Fox Street • Room 204

Yorkville, IL • 60560

(630) 553-4141

Fax (630) 553-4179

MEMORANDUM

To: Kendall County Board

From: Matthew H. Asselmeier, AICP, Senior Planner

Date: November 14, 2018

Re: 17-28 Proposed Text Amendments to Sections 7.01.D.32, 7.01.D.33 and 10.03.B.4 of the Kendall County Zoning Ordinance Pertaining to Regulations of Outdoor Target Practice or Shooting Ranges (Not Including Private Shooting in Your Own Yard)

In 2017, the Kendall County Planning, Building and Zoning Committee researched outdoor target practice and shooting range regulations of several neighboring and nearby counties. After submitting an initial proposal to the advisory boards and receiving their feedback and the feedback of other interested parties, the Planning, Building and Zoning Committee drafted the current proposal and started the adoption process in June 2018.

A redlined version of the existing regulations compared to the proposal is attached. The proposal is also attached.

ZPAC reviewed the original proposal, but did not review the amended proposal.

At their meeting on July 25, 2018, the Kendall County Regional Planning Commission unanimously recommended denial of the proposal.

The following comments on the proposal were provided at the July 25th meeting:

Ms. Wilson looked into the downstate Downstate Forest Preserve Act and could not find exemptions that pertained to the special use permit applied to the Kendall County Forest Preserve. There are permits that can be granted to outside users. Ms. Wilson also questioned where the source of the proposal originated. Mr. Asselmeier noted the Planning, Building and Zoning Committee made the final call for what was put in the proposal. Ms. Wilson questioned what reason for the minimum of five (5) acre lot size. Mr. Asselmeier noted it was set at that requirement back in 2015. The Planning, Building and Zoning Committee wanted the dimensions to be based on the setbacks, berming requirements and type of firearm. All the other setbacks would have to be met, even if the five (5) acre requirement is not obtained.

Mr. Nelson stated that the decision of the County Board on this matter is not based on law. He questioned why the language should be put in if the Kendall County Forest Preserve is exempted. If the regulations are already in the law, there is no reason to put it in the ordinance. Mr. Nelson understood looking at petitions on a case-by-case basis, but did feel that greater direction was needed.

Mr. Shaw questioned the noise requirement and if shooting can last all night. Chairman Ashton responded that it depends on a case-by-case basis and that shooting could

County Board Memo

November 14, 2018

occur all night under the proposal. Chairman Ashton noted the Sheriff Department's range was approved years ago and the proposal does not apply to that range.

Discussion occurred regarding the Sheriff Department's range. Mr. Davidson responded that the special use allows lights. Chairman Ashton noted the special use permit did not allow lights. However, the special use permit should include lights if someone wants to put up lights. Mr. Nelson noted, if someone has a special use permit with no restrictions on hours of operation, it is reasonable for the individual to put up lights. Mr. Asselmeier noted the time for the range was 7 a.m. to 8 p.m. and that lighting shall meet the standards of the zoning order. Ms. Wilson agreed with Mr. Shaw. She stated she lives next to a shooting range and would not be okay with it going on after 10 p.m. She also advocated for a lower decibel level because noise can be disruptive and dangerous to the public.

The Kendall County Zoning Board of Appeals held a public hearing on this proposal on August 27, 2018. The Zoning Board of Appeals voted to recommend denial of the proposal with two (2) members voting in favor and four (4) members voting against the proposal. Mr. LeCuyer stated the proposal needs to reference the qualifications for the range masters. Mr. Fox stated the overall issues with the proposal such as safety, qualifications for range master, and the hours of operation. Mr. Cherry stated the proposal has too many grey issues for him and the proposal needs to be reworked. Chairman Mohr stated his concerns are there should be a minimum standard and modified later with variances if needed. The range master qualifications needed to be fixed and minimum should be kept in the proposal. The complete record of the Zoning Board of Appeals hearing can be found at https://www.co.kendall.il.us/wp-content/uploads/Petition_17-28.pdf.

The townships have been informed of this proposal. On September 19, 2018, Na-Au-Say Township filed a formal objection. Their objection and reasons for objecting to the proposal are attached to this memo.

Several residents submitted concerns regarding this proposal. Their concerns were discussed at the November 13, 2018, Planning, Building and Zoning Committee meeting and are attached to this memo.

If you have any questions prior to the meeting on this topic, please let me know.

Thanks,

MHA

**ENC: Redlined Version of the Existing Regulations
Proposed Text Amendment
Na-Au-Say Township Objection
Na-Au-Say Township's Reasons for Objecting
Concerns of Residents**

Outdoor Target Practice or Shooting (not including private shooting ~~in your own yard~~ on your own property or shooting ranges located on property owned by the Kendall County Forest Preserve District or the State of Illinois used for State Parks) with the following conditions:

- a. Requires conformity with NRA standards; provide appropriate berming based on surrounding land use and type(s) of firearms to be used. Such as berming shall generally be consistent with standards established in the NRA Source Book. (See requirements b, c, and d of the proposal)**
 - b. ~~Requires minimum parcel size of 5 acres, depending on the venue.~~ Must meet setbacks of the zoning district. (See requirement k of the proposal)**
 - c. Must have a sign that lists allowed firearm types based on the special use permit, rules of operation; hearing and vision protection required. (See requirement f of the proposal)**
 - d. ~~State-recognized, nationally-recognized or NRA Certified range supervisor~~ At least one (1) designated qualified person must be present at all times when firing is taking place at for-profit outdoor target practice or shooting ranges. The qualified person shall be knowledgeable of the type of shooting being supervised, shall be approved by the owner of the range, and shall know and enforce all range rules. (See requirement g of the proposal)**
 - e. At least one (1) Range flag flown, a sign, cone, or red light lit at all times that firing is taking place. (See requirement h of the proposal)**
 - f. Hours and days of operation as specified in the Special Use Permit to be determined by the County Board. (Unchanged-see requirement i of the proposal)**
 - g. Access must be controlled by a gated entrance ~~lockable gate~~. The range proper shall be gated and fenced in a manner so to prohibit entrance on the property by members of the public and shall have signs posted at one hundred foot (100') intervals warning members of the public of the danger. Berming may substitute for fencing. (See requirement j of the proposal)**
 - h. Hazardous waste plan addressing lead management required. (See requirement a of the proposal)**
 - i. No discharge of lead shot into wetland. (See requirement o of the proposal).**
 - j. ~~Must be at least 1,000' from existing dwellings and property lines of schools, daycares, places of worship and airstrips.~~ Must meet setbacks of the zoning district. (See requirement k of the proposal)**
 - k. No alcohol allowed. (Unchanged-see requirement l of the proposal)**
 - l. No projectiles shall leave the boundaries of the site. (Unchanged-see requirement m of the proposal)**
 - m. All applicable Federal, State and County local rules and regulations shall be adhered to. (See requirement o of the proposal)**
 - n. Must meet all requirements of the Kendall County Health Department. (See requirement o of the proposal)**
-

o. Water and drainage plans must be approved by the Kendall County Planning, Building and Zoning Office. (See requirement a of the proposal)

p. Signage is permitted but must meet the Sign Ordinance regulations of Section 12 of the Zoning Ordinance. (See requirement o of the proposal)

q. Lighting shall meet the standards of Section 11.02.F.12.d of the Zoning Ordinance. (See requirement o of the proposal)

r. Must adhere to the Performance standards of Section 10.01.F of the Zoning Ordinance (Unchanged-see requirement p of the proposal)

New regulations:

- 1. Safety area and range must be under the control of the operator of the range. (Requirement e)**
 - 2. Insurance requirement added. (Requirement n)**
 - 3. Noise requirement added; no distinction between day and night. (Requirement q)**
 - 4. New ordinance does not apply to existing ranges. (Requirements r and s)**
 - 5. New ranges open to the public are governed by this ordinance (Requirements r and s)**
 - 6. Easement provision contained in previous proposals was removed.**
-

ORDINANCE # 2018-_____

TEXT AMENDMENT TO SECTIONS 7.01.D.32, 7.01.D.33 AND 10.03.B.4 OF THE KENDALL COUNTY ZONING ORDINANCE PERTAINING REGULATIONS OF OUTDOOR COMMERCIAL SPORTING ACTIVITIES AND OUTDOOR TARGET PRACTICE OR SHOOTING RANGES (NOT INCLUDING PRIVATE SHOOTING IN YOUR OWN YARD)

WHEREAS, 55 ILCS 5/5-12001 grants Kendall County the authority to regulate and restrict the location and use of structures and uses for the purpose of promoting the public health, safety, morals, comfort and general welfare throughout the unincorporated areas of the County; and

WHEREAS, gun clubs were a permitted use in the A-1 Agricultural District under the Kendall County Zoning Ordinance adopted January 16, 1940; and

WHEREAS, gun clubs were reclassified as a special use in the A-1 Agricultural District under the Kendall County Zoning Ordinances adopted in 1959 and July 9, 1974; and

WHEREAS, outdoor shooting ranges were classified as a similar use to gun clubs per the hearing of the Kendall County Zoning Board of Appeals on September 30, 1982 and were included as a special use in the A-1 Agricultural District by Ordinance 82-11 adopted November 9, 1982; and

WHEREAS, the restrictions governing target practice or shooting (not including private shooting in your own yard) in the A-1 Agricultural District and M-3 Earth Materials Extraction, Processing and Site Reclamation District were established through Ordinance 2013-14 adopted July 16, 2013; and

WHEREAS, Section 13.07 of the Kendall County Zoning Ordinance permits the Kendall County Board to approve text amendments and provides the procedure through which text amendments are granted; and

WHEREAS, on or about September 11, 2017, the Kendall Count Planning, Building and Zoning Committee, hereinafter be referred to as "Petitioner", submitted a text amendment to the Kendall County Zoning Ordinance pertaining to outdoor target practice and shooting range zoning regulations; and

WHEREAS, on or about June 11, 2018, the Petitioner amended the proposed text amendment;

and

WHEREAS, following due and proper notice by publication in the Kendall County Record on August 9, 2018, the Kendall County Zoning Board of Appeals conducted a public hearing on August 27, 2018, at 7:00 p.m., in the County Office Building at 111 W. Fox Street in Yorkville, at which the Petitioner and the Petitioner's representative presented evidence, testimony, and exhibits in support of the requested text amendment and four (4) members of the public testified in favor of the request and eleven (11) members of the public testified in opposition to the request; and

WHEREAS, based on the evidence, testimony, and exhibits, the Kendall County Zoning Board of Appeals has recommended denial of the text amendment on August 27, 2018; and

WHEREAS, 55 ILCS 5/5-12014 (c) grants certain townships the right to file formal objections to proposed text amendments; and

WHEREAS, the Township of Na-Au-Say did file a formal objection in a manner permissible by State law; and

WHEREAS, 55 ILCS 5/5-12014 (c) requires the approval of at least three-fourths of a County Board to approve a text amendment over the formal objection of certain townships; and

WHEREAS, the Kendall County Planning, Building and Zoning Committee of the Kendall County Board has reviewed the testimony presented at the aforementioned public hearing and Recommendation of the Kendall County Zoning Board of Appeals, and has forwarded to the Kendall County Board the requested text amendment; and

WHEREAS, the Kendall County Board has considered the recommendations of the Planning, Building and Zoning Committee and the Kendall County Zoning Board of Appeals, and has determined that said petition is in conformance with the provisions and intent of the Kendall County Zoning Ordinance; and

NOW, THEREFORE, BE IT ORDAINED, the Kendall County Board hereby amends Sections 7.01.D.32, 7.01.D.33 and 10.03.B.4 of the Kendall County Zoning Ordinance as provided:

- I. Recitals: The recitals set forth above are incorporated as if fully set forth herein.
- II. Amended Text: The existing language of Section 7.01.D.32 is hereby deleted and replaced with the following:

“7.01.D.32 Outdoor Commercial Sporting Activities including but not limited to swimming facilities and motocross sports. Appropriate regulations for lighting noise and hours of operation shall be included in the conditions. Outdoor commercial sporting activities shall

exclude outdoor target practice (such exclusion extends to shooting ranges located on property owned by the Kendall County Forest Preserve District or the State of Illinois used for State parks), athletic fields with lights, paintball facilities and riding stables, including but not limited to polo clubs, and similar uses.”

III. Amended Text: The existing language of Section 7.01.D.33 is hereby deleted and replaced with the following:

“7.01.D.33 Outdoor Target Practice or Shooting (but not including private shooting on your own property or shooting ranges located on property owned by the Kendall County Forest Preserve District or the State of Illinois used for State parks) with the following conditions:

- a. At the time of application for a special use permit, petitioners desiring to operate an outdoor target practice or shooting ranges shall submit copies of all of the studies and plans suggested in the National Rifle Association’s Source Book including, but not limited to, a safety plan, a business plan, a public relations plan, a maintenance plan, a noise plan, an environmental stewardship plan, and a closure plan.
 1. The above referenced plans shall contain information as suggested by the National Rifle Association.
 2. Included in the above documents, the petitioner shall submit a detailed written narrative describing the proposed use. This narrative shall, at minimum, describe the type of range (i.e. public, private, or government), the type(s) of firearms and targets expected to be used and the proposed days and hours of operation.
 3. The safety plan shall describe the duties and qualifications of range supervisor(s).
 4. In at least one (1) of the required studies or plans, a hazardous waste plan addressing lead management shall be included. The lead management plan shall conform to either the requirement of the National Rifle Association’s standards, the National Shooting Sports Foundation’s standards, or the United States Environmental Protection Agency’s best management practices standards.
 5. In addition to the above requirements, the petitioner shall submit a water and drainage plan; this plan must be approved by the Kendall County Planning, Building and Zoning Office.
 6. Any changes to the above required studies and plans shall be promptly forwarded to the Kendall County Planning, Building and Zoning Department.
- b. Range layout requires conformity with National Rifle Association standards with regard to layout and dimensions. The petitioner shall submit a site capacity with a calculation and a detailed site plan showing the layout and design of the proposed shooting range, including all

required setbacks and landscaping and the existing and proposed structures, their floor areas and impervious surfaces. The scale of the site plan shall be no greater than one inch equals one hundred feet (1"=100'). A licensed engineer or land surveyor shall prepare the documents.

- c. The site plan for the proposed outdoor target practice or shooting range must show either sufficient berm height with sufficient downrange safety area or baffling that prevents projectiles from leaving the site.
 1. The safety area shall conform to National Rifle Association's standards for the shape and width. The safety area shall have signs posted at intervals stated in the special use permit warning of the potential danger from stray bullets.
 2. For the purposes of this regulation, the term "downrange safety area" shall mean the area away from the launching site towards the target. In cases of shooting ranges where targets are not stationary, appropriate baffling shall be provided.
- d. Public ranges designed for the use of handguns and rifles shall provide berms at least twenty feet (20') high and six feet (6') thick at the top for ranges three hundred feet (300') in length, made of soft earth or other material that is unlikely to cause ricochets, and containing no large rocks. For every thirty feet (30') of firing line distance over twenty feet (20'), the berm height shall increase by ten feet (10') in height as an example. Berms shall be located as follows:
 1. Shotgun ranges – No berming required.
 2. Ranges for handguns and rifles
 - a. Target placement not to exceed twenty feet (20') from the backstop.
 - b. Lateral not closer than thirty feet (30') from the firing line.
 3. All required berms shall be constructed prior to the commencement of operations and shall be maintained for the duration of the special use permit.
 4. In addition to berms, appropriate baffling may be installed over the firing line creating a "no blue sky" to prevent projectiles from overshooting the berm.
- e. The range, including the safety area, must be under the control of the operator of the range, by ownership or lease.
- f. The outdoor target practice or shooting range must have a sign that lists allowed firearm types based on the special use permit, rules of operation; hearing and vision protection required.
- g. At least one (1) designated qualified person must be present at all times when firing is taking place at for-profit outdoor target practice or shooting

ranges. The qualified person shall be knowledgeable of the type of shooting being supervised, shall be approved by the owner of the range, and shall know and enforce all range rules.

- h. At least one (1) range flag flown, a sign, cone, or red light lit at all times that firing is taking place.
- i. Hours and days of operation shall be specified in the special use permit and determined by the County Board.
- j. Access must be controlled by a gated entrance. The range proper shall be gated and fenced in a manner so to prohibit entrance on the property by members of the public and shall have signs posted at one hundred foot (100') intervals warning members of the public of the danger. Berming may substitute for fencing.
- k. Must meet existing setbacks of the zoning district.
- l. No alcohol allowed.
- m. No projectiles shall leave the boundaries of the site.
- n. The outdoor target practice or shooting range allowed by this special use permit shall provide the Kendall County Planning, Building and Zoning Department proof of accident and liability insurance prior to the commencement of operations; the insurance amount shall be at a level standard and customary for an outdoor target practice or shooting range. The insurance policy must be purchased from an A+ rated insurance company. An insurance policy meeting the above requirements must be maintained during the duration of the special use permit.
- o. All applicable Federal, State and local rules and regulations shall be adhered to.
- p. Must adhere to the Performance standards of Section 10.01.F of the Zoning Ordinance (Not more than sixty percent (60%) of the area of the lot may be covered by buildings or structures, including accessory buildings).
- q. No person shall cause or allow the emission of sound from any noise source to any receiving residential land which exceeds sixty-five (65) dBA when measured at any point within such receiving residential land provided; however, that point of measurement shall be on the residential

property line of the complainant.

- r. Outdoor target practice and public or private shooting ranges in existence prior to the date of the adoption of this ordinance (November 20, 2018) shall be exempt from this sub-section of the Zoning Ordinance, but they shall follow the restrictions on their respective special use permits.
- s. Outdoor target practice and shooting ranges open to the public established after the date of the adoption of this ordinance (November 20, 2018) must comply with the above regulations or secure applicable variance(s).”

IV. Amended Text: The existing language of Section 10.03.B.4 is hereby deleted and replaced with the following:

“10.03.B.4 Outdoor Target Practice or Shooting (not including private shooting on your own property and shooting ranges located on property owned by the Kendall County Forest Preserve District or the State of Illinois used for State parks) with the following conditions:

- a. At the time of application for a special use permit, petitioners desiring to operate an outdoor target practice or shooting ranges shall submit copies of all of the studies and plans suggested in the National Rifle Association’s Source Book including, but not limited to, a safety plan, a business plan, a public relations plan, a maintenance plan, a noise plan, an environmental stewardship plan, and a closure plan.
 - 1. The above referenced plans shall contain information as suggested by the National Rifle Association.
 - 2. Included in the above documents, the petitioner shall submit a detailed written narrative describing the proposed use. This narrative shall, at minimum, describe the type of range (i.e. public, private, or government), the type(s) of firearms and targets expected to be used and the proposed days and hours of operation.
 - 3. The safety plan shall describe the duties and qualifications of range supervisor(s).
 - 4. In at least one (1) of the required studies or plans, a hazardous waste plan addressing lead management shall be included. The lead management plan shall conform to either the requirement of the National Rifle Association’s standards, the National Shooting Sports Foundation’s standards, or the United States Environmental Protection Agency’s best management practices standards.
 - 5. In addition to the above requirements, the petitioner shall submit a water and drainage plan; this plan must be approved by the Kendall County Planning, Building and Zoning Office.

6. Any changes to the above required studies and plans shall be promptly forwarded to the Kendall County Planning, Building and Zoning Department.
-
- b. Range layout requires conformity with National Rifle Association standards with regard to layout and dimensions. The petitioner shall submit a site capacity with a calculation and a detailed site plan showing the layout and design of the proposed shooting range, including all required setbacks and landscaping and the existing and proposed structures, their floor areas and impervious surfaces. The scale of the site plan shall be no greater than one inch equals one hundred feet (1"=100'). A licensed engineer or land surveyor shall prepare the documents.
 - c. The site plan for the proposed outdoor target practice or shooting range must show either sufficient berm height with sufficient downrange safety area or baffling that prevents projectiles from leaving the site.
 1. The safety area shall conform to National Rifle Association's standards for the shape and width. The safety area shall have signs posted at intervals stated in the special use permit warning of the potential danger from stray bullets.
 2. For the purposes of this regulation, the term "downrange safety area" shall mean the area away from the launching site towards the target. In cases of shooting ranges where targets are not stationary, appropriate baffling shall be provided.
 - d. Public ranges designed for the use of handguns and rifles shall provide berms at least twenty feet (20') high and six feet (6') thick at the top for ranges three hundred feet (300') in length, made of soft earth or other material that is unlikely to cause ricochets, and containing no large rocks. For every thirty feet (30') of firing line distance over twenty feet (20'), the berm height shall increase by ten feet (10') in height as an example. Berms shall be located as follows:
 1. Shotgun ranges – No berming required.
 2. Ranges for handguns and rifles
 - a. Target placement not to exceed twenty feet (20') from the backstop.
 - b. Lateral not closer than thirty feet (30') from the firing line.
 3. All required berms shall be constructed prior to the commencement of operations and shall be maintained for the duration of the special use permit.
 4. In addition to berms, appropriate baffling may be installed over the firing line creating a "no blue sky" to prevent projectiles from overshooting the berm.

- e. The range, including the safety area, must be under the control of the operator of the range, by ownership or lease.
- f. The outdoor target practice or shooting range must have a sign that lists allowed firearm types based on the special use permit, rules of operation; hearing and vision protection required.
- g. At least one (1) designated qualified person must be present at all times when firing is taking place at for-profit outdoor target practice or shooting ranges. The qualified person shall be knowledgeable of the type of shooting being supervised, shall be approved by the owner of the range, and shall know and enforce all range rules.
- h. At least one (1) range flag flown, a sign, cone, or red light lit at all times that firing is taking place.
- i. Hours and days of operation shall be specified in the special use permit and determined by the County Board.
- j. Access must be controlled by a gated entrance. The range proper shall be gated and fenced in a manner so to prohibit entrance on the property by members of the public and shall have signs posted at one hundred foot (100') intervals warning members of the public of the danger. Berming may substitute for fencing.
- k. Must meet existing setbacks of the zoning district.
- l. No alcohol allowed.
- m. No projectiles shall leave the boundaries of the site.
- n. The outdoor target practice or shooting range allowed by this special use permit shall provide the Kendall County Planning, Building and Zoning Department proof of accident and liability insurance prior to the commencement of operations; the insurance amount shall be at a level standard and customary for an outdoor target practice or shooting range. The insurance policy must be purchased from an A+ rated insurance company. An insurance policy meeting the above requirements must be maintained during the duration of the special use permit.
- o. All applicable Federal, State and local rules and regulations shall be adhered to.

- p. Must adhere to the Performance standards of Section 10.01.F of the Zoning Ordinance (Not more than sixty percent (60%) of the area of the lot may be covered by buildings or structures, including accessory buildings).
- q. No person shall cause or allow the emission of sound from any noise source to any receiving residential land which exceeds sixty-five (65) dBA when measured at any point within such receiving residential land provided; however, that point of measurement shall be on the residential property line of the complainant.
- r. Outdoor target practice and public or private shooting ranges in existence prior to the date of the adoption of this ordinance (November 20, 2018) shall be exempt from this sub-section of the Zoning Ordinance, but they shall follow the restrictions on their respective special use permits.
- s. Outdoor target practice and shooting ranges open to the public established after the date of the adoption of this ordinance (November 20, 2018) must comply with the above regulations or secure applicable variance(s).”

V. Any completed application submitted prior to the date of the adoption of this ordinance shall follow the application procedures, requirements and restrictions in effect on the date that the completed application was submitted.

IN WITNESS OF, this amendment to the Kendall County Zoning Ordinance has been enacted by a supermajority vote of the Kendall County Board this 20th day of November, 2018.

Attest:

 Kendall County Clerk
 Debbie Gillette

 Kendall County Board Chairman
 Scott R. Gryder

Matt Asselmeier

From: Brad Blocker [bblocker@gablocker.com]
Sent: Wednesday, September 19, 2018 4:08 PM
To: Matt Asselmeier
Subject: Amended Petition 17-28

Matt,

On September 17th 2018 the Na Au Say Township Plan Commission met to discuss and consider public comments and make a recommendation to the Na Au Say Township Board regarding Amended Petition 17-28 . After discussions a motion was made, and seconded , to approve support for the Amended Petition . Motion failed 3-0 .

On September 17th 2018 during the regular monthly meeting the Township Board discussed the recommendation from the Plan Commission and a motion was made , and seconded , to formally notify to the Kendall County Board that Na Au Say Township does NOT support the Amended Petition 17-28 .

Motion passed 5-0

Any question please feel free to contact me

Thank You,

Brad

Bradley A. Blocker
Supervisor

Na-Au-Say Township

"Headwaters of the aux-sable"

Office : 815-254-7708

Mobile : 630-417-2744

STATE OF ILLINOIS
COUNTY OF KENDALL
- FILED -

SEP 21 2018

Debbie Schutte COUNTY CLERK
KENDALL COUNTY

Matt Asselmeier

From: Brad Blocker [bblocker@gablocker.com]
Sent: Monday, September 24, 2018 11:44 AM
To: Matt Asselmeier
Cc: Scott Koepfel
Subject: RE: Amended Petition 17-28

Some of the concerns that were discussed were :

- Safety Area –Set backs and buffers too close and not well defined
- Fencing – should be fenced in and gate, berm should not be alternate
- Hours of operation – needs to be defined, no after dark
- Minimum land size –needs to be more, and defined
- Noise- negative impact for neighbors , not well defined
- Why is the County Board keeping this as Special Use and not Commercial ?
- Based on past experiences , there is general lack of confidence that County will properly regulate terms of Special Use permit .

These are just some bullet points of the concerns that were had. If you would like further explanation let me know ,feel free to call.

Thank You,

Brad

Bradley A. Blocker
Supervisor

Na-Au-Say Township

"Headwaters of the aux-suble"

Office : 815-254-7708

Mobile : 630-417-2744

From: Matt Asselmeier [mailto:masselmeier@co.kendall.il.us]
Sent: Monday, September 24, 2018 10:05 AM
To: Brad Blocker
Cc: Scott Koepfel
Subject: RE: Amended Petition 17-28

Brad:

Kendall County Planning, Building and Zoning Committee Chairman Davidson was wondering the reason(s) that Na-Au-Say Township was filing this formal objection. Could you let me know your concerns with the proposal?

Thanks,

Matthew H. Asselmeier, AICP
Senior Planner
Kendall County Planning, Building & Zoning
111 West Fox Street

Summary of Proposed Changes to Kendall County Gun Range Ordinance

1. Include special use for commercial ranges in M-3 zoning only.
 2. Redefine ranges covered by special use requirements to include retail commercial use property and property allowing specified number of simultaneous shooters.
 3. Incorporate range design requirements from U.S. Government Range Design Criteria rather than from the National Rifle Association.
 4. Minimum parcel size of 20 acres.
 5. Insurance requirements.
 6. Daylight hours only.
 7. Locked and gated entrance.
 8. Law enforcement, fire and emergency personnel security access.
 9. Buffer of 3000 feet from dwellings, schools, churches, airstrips.
 10. No alcohol or drug use allowed.
 11. Kendall County residential noise regulations apply.
 12. Existing permitted ranges continue as they are.
-

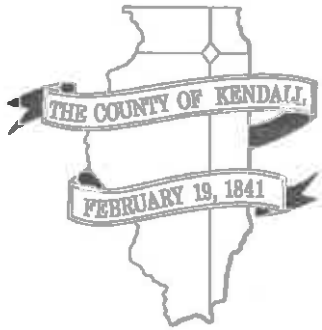

DEPARTMENT OF PLANNING, BUILDING & ZONING

111 West Fox Street • Room 204

Yorkville, IL • 60560

(630) 553-4141

Fax (630) 553-4179

MEMORANDUM

To: Kendall County Committee of the Whole
From: Matthew H. Asselmeier, AICP, Senior Planner
Date: November 5, 2018
Re: Proposed Future Land Use Map Change Along Route 47 in Lisbon Township

In 2017, the Kendall County Regional Planning Commission and Comprehensive Land Plan and Ordinance Committee started the process of considering amendments to the Future Land Use Map in Lisbon Township along Route 47. The reason for considering changes at this time was because of the widening of Route 47 to four (4) lanes in Lisbon Township.

The proposed changes were based on the following:

1. The mining area was designated because that was the location of the rock.
2. A commercial area should be designated on the east side of Route 47 north of the Grundy County line because everything else in the area was proposed to be industrial/office use.
3. The intersection of Routes 47 and 52 were designed as commercial to provide the Village of Lisbon an opportunity to place sales tax generating business. The southeast corner of this intersection was designated mixed use business because of the grain operation at this location.
4. The intersection of Route 47 and Plattville Road was designed as commercial to provide the Village of Plattville an opportunity to place sale tax generating businesses.
5. The rest of the corridor was classified as mixed use business.
6. Outer roads were proposed on both sides of Route 47 to prevent the highway from becoming congested with multiple turnouts.
7. Because of the need for buffering the mining area, the need for outer roads, and the anticipated businesses that would locate along the corridor, the corridor was set at one half (1/2) mile wide on both sides of Route 47.

On February 28, 2018, the Kendall County Regional Planning Commission and Comprehensive Land Plan and Ordinance Committee held a joint meeting in Plattville. Sixteen (16) members of the public attended the meeting. The overwhelming majority of the public in attendance favored maintaining the entire corridor as agricultural. A small minority favored small businesses like Casey's at Routes 47 and 52. Nobody in the audience favored commercial and industrial uses along the corridor when specifically asked. The Village of Lisbon also explained their sanitary sewer situation.

Following the meeting in Plattville, the Comprehensive Land Plan and Ordinance Committee decided to incorporate the Village of Lisbon's Future Land Use Map in the proposed map. Shortly thereafter, the State announced that it was not renewing the centerline protection of the Prairie Parkway. The consensus of the Comprehensive Land Plan and Ordinance Committee was to retain the Prairie Parkway alignment on the map for the short term as an historical reference point for planning purposes.

The Kendall County Regional Planning Commission held a public hearing on this proposal on June 27, 2018. With minimal discussion and nobody from the public expressing opposition, the Kendall County Regional Planning Commission unanimously recommended approval of the proposal.

The Kendall County Zoning Board of Appeals held a meeting on this proposal on July 30, 2018.

Seven (7) members of the public expressed opposition to this proposal and nobody from the public spoke in favor of the proposal. Many of those that spoke desired to preserve farmland and prevent the expansion of mining in the area. Some of the members of the public were concerned that, if the proposal was approved, the door would be opened to non-agricultural uses along the corridor. One (1) member of the public wanted the Prairie Parkway alignment removed because showing the alignment did not serve a planning purpose in their opinion. The Kendall County Zoning Board unanimously recommended denial. Ms. Clementi agreed with Mr. Thompson and Mr. LeCuyer and believed more input from the community should be taken into account. She wished for agriculture to be preserved in the area. Mr. Cherry understood the residents' opinions on the matter, but he was still on the fence and just thought he should vote no. Mr. Thompson stated he had some problems with the proposal since he comes from an agriculture background. Also, he stated the importance of a plan. Mr. Whitfield recommended that anyone wanting to preserve their land should work with the Conservation Foundation. Mr. LeCuyer stated there should be more discussion with the residents in the area. He argued there was use and value to the land and the only way to preserve the land is placing it in a conservation trust. Chairman Mohr stated the plan was meant to be a fluid document. He reiterated that zoning is not going to be changed but does believe that certain parts of the proposal needed to be reexamined. He believed that the Prairie Parkway should be kept for on the map for historical purposes. He also argued the one half (1/2) mile corridor was excessive.

At the Zoning Board of Appeals meeting, five (5) attendees indicated they did not receive notification of the meeting by letter. Staff mailed the letters July 5th; the letters were not sent certified because Staff believes that State law does not require certified mailings for changes to the Land Resource Management Plan. Unlike a rezoning, a change to the Future Land Use Plan is not binding and has no direct legal action on what a property owner can and cannot do with their land.

The Kendall County Planning, Building and Zoning Committee discussed this issue at their meeting in August, September, and October 2018. The Committee recommended that the proposal be forwarded to the Committee of the Whole to allow residents to voice their concerns directly to County Board members.

The record of information to this point can be found at https://www.co.kendall.il.us/wp-content/uploads/Petition_18-04.pdf.

If you have any questions, please let me know.

MHA

ENC: Draft Resolution
Existing Lisbon Township Future Land Use Map
Village of Lisbon Future Land Use Map

RESOLUTION NUMBER 2018-_____

A RESOLUTION ADOPTING AN AMENDMENT TO THE KENDALL COUNTY LAND RESOURCE MANAGEMENT PLAN TO UPDATE THE FUTURE LAND USE PLAN IN LISBON TOWNSHIP IN THE VICINITY OF ROUTE 47

WHEREAS, 50 ILCS 805 allows Counties to create and adopt Land Resource Management Plans; and

WHEREAS, 55 ILCS 5/5-14001 through 5-14008 specifies how a County may adopt and amend Official Plans; and

WHEREAS, Kendall County adopted a Land Resource Management Plan in March 1994; and

WHEREAS, the Kendall County Board has amended the Land Resource Management Plan on several occasions since its adoption in March 1994; and

WHEREAS, the Kendall County Land Resource Management Plan has adopted a Policy, Framework, Planning Goals & Objectives, Management Goals & Objectives, and Land Resource and Management Area Policies for the County; and

WHEREAS, the Kendall County Land Resource Management Plan has adopted official Future Land Use Maps for each township and for the County as a whole; and

WHEREAS, Illinois State Route 47 was widened to four lanes in Lisbon Township; and

WHEREAS, the Village of Lisbon adopted a Comprehensive Plan in January 2009 which included proposed land uses along a portion of Illinois State Route 47 in Lisbon Township; and

WHEREAS, the Kendall County Regional Planning Commission, hereinafter be referred to as "Petitioner," believes that future land uses along Illinois State Route 47 will change due to the widening of the highway in Lisbon Township and that the Kendall County Land Resource Management Plan should be amended to incorporate portions of the Village of Lisbon's Comprehensive Plan; and

WHEREAS, on February 28, 2018, Petitioner held a public meeting in the Village of Plattville at 6410 Chicago Road, Yorkville, Illinois to obtain input from the residents of Lisbon Township and two members of the public expressed opposition to the proposal; and

WHEREAS, following due and proper notice by publication in the Kendall County Record not less than fifteen days prior thereto, the Kendall County Regional Planning Commission conducted a public hearing on June 27, 2018, at 7:00 p.m., in the County Office Building at 111 W. Fox Street in Yorkville, at which the Petitioner presented evidence, testimony, and exhibits in support of the requested amendment and one member of the public asked questions and zero members of the public testified in favor or testified in opposition to the request; and

WHEREAS, following due and proper notice by publication in the Kendall County Record not less than fifteen days prior thereto, the Kendall County Zoning Board of Appeals met on July 30, 2018, at 7:00 p.m., in the County Office Building at 111 W. Fox Street in Yorkville, at which the Petitioner presented evidence, testimony, and exhibits in support of the requested map amendment and seven members of the public expressed opposition to the proposal; and

WHEREAS, based on the evidence, testimony, and exhibits, the Kendall County Zoning Board of Appeals has recommended denial of the proposed amendment; and

WHEREAS, the Kendall County Planning, Building and Zoning Committee of the Kendall County Board has reviewed the testimony presented at the aforementioned public hearing and meetings, and has forwarded to the Kendall County Board a recommendation of approval of the proposed amendment; and

WHEREAS, the Kendall County Board has considered the recommendation of the Planning, Building and Zoning Committee, the recommendation of the Kendall County Zoning Board of Appeals, the record of the public hearing conducted by the Kendall County Regional Planning Commission, the recommendation of the Kendall County Regional Planning, and has determined that said proposed amendment to the Kendall County Land Resource Management Plan is necessary and in the best interests of Kendall County; and

NOW, THEREFORE, BE IT RESOLVED, BY THE COUNTY BOARD OF KENDALL COUNTY, ILLINOIS, as follows:

1. The revisions to the Future Land Use Plan of the Land Resource Management Plan, attached hereto as Exhibit A, are hereby adopted as an amendment to the Kendall County Land Resource Management Plan.
2. Any text or maps contained in the Kendall County Land Resource Management Plan in conflict with the attached Exhibit A are hereby repealed.

IN WITNESS OF, this resolution has been enacted by a majority vote of the Kendall County Board and is effective this 20th day of November, 2018.

Attest:

Kendall County Clerk
Debbie Gillette

Kendall County Board Chairman
Scott R. Gryder

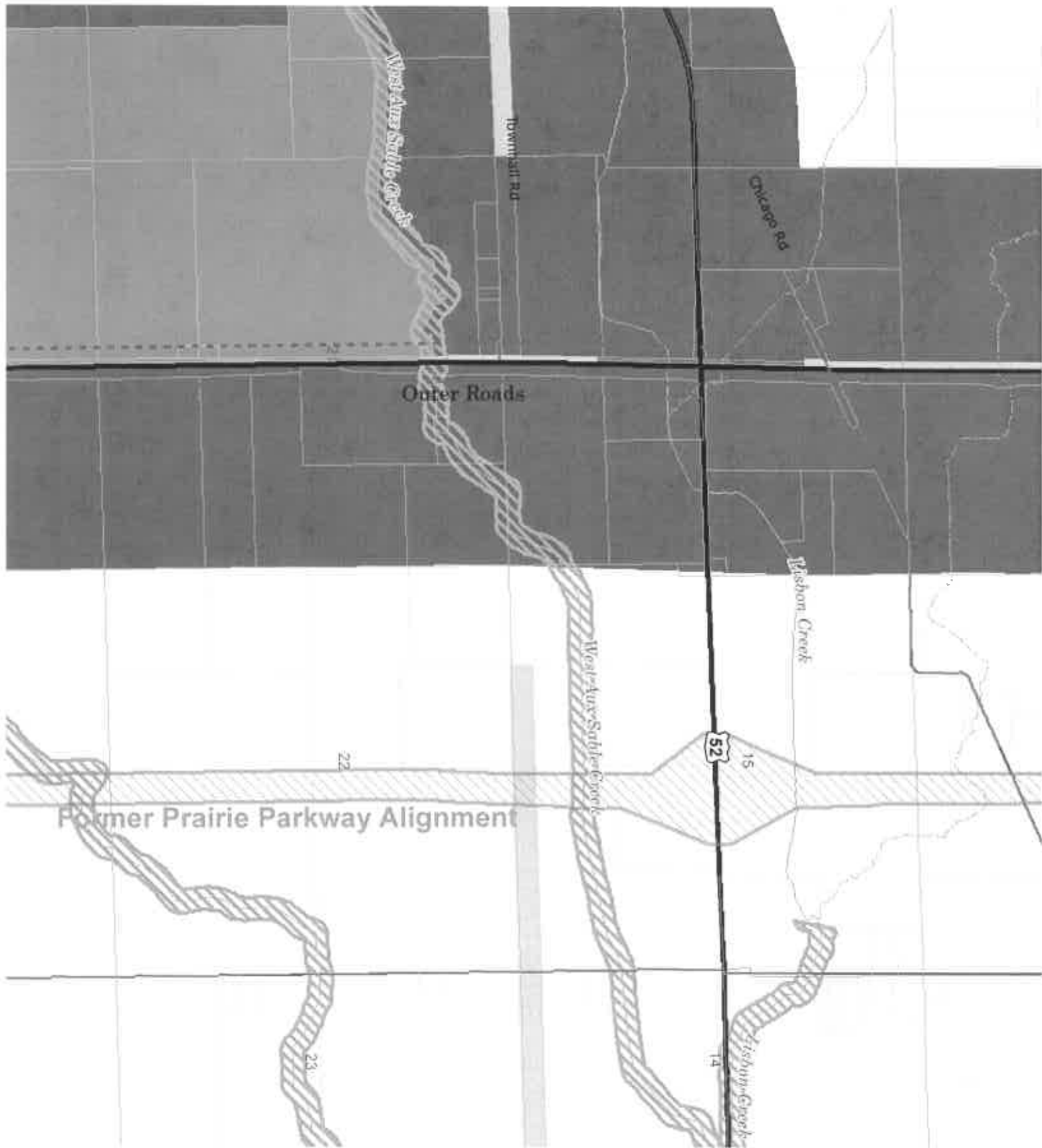

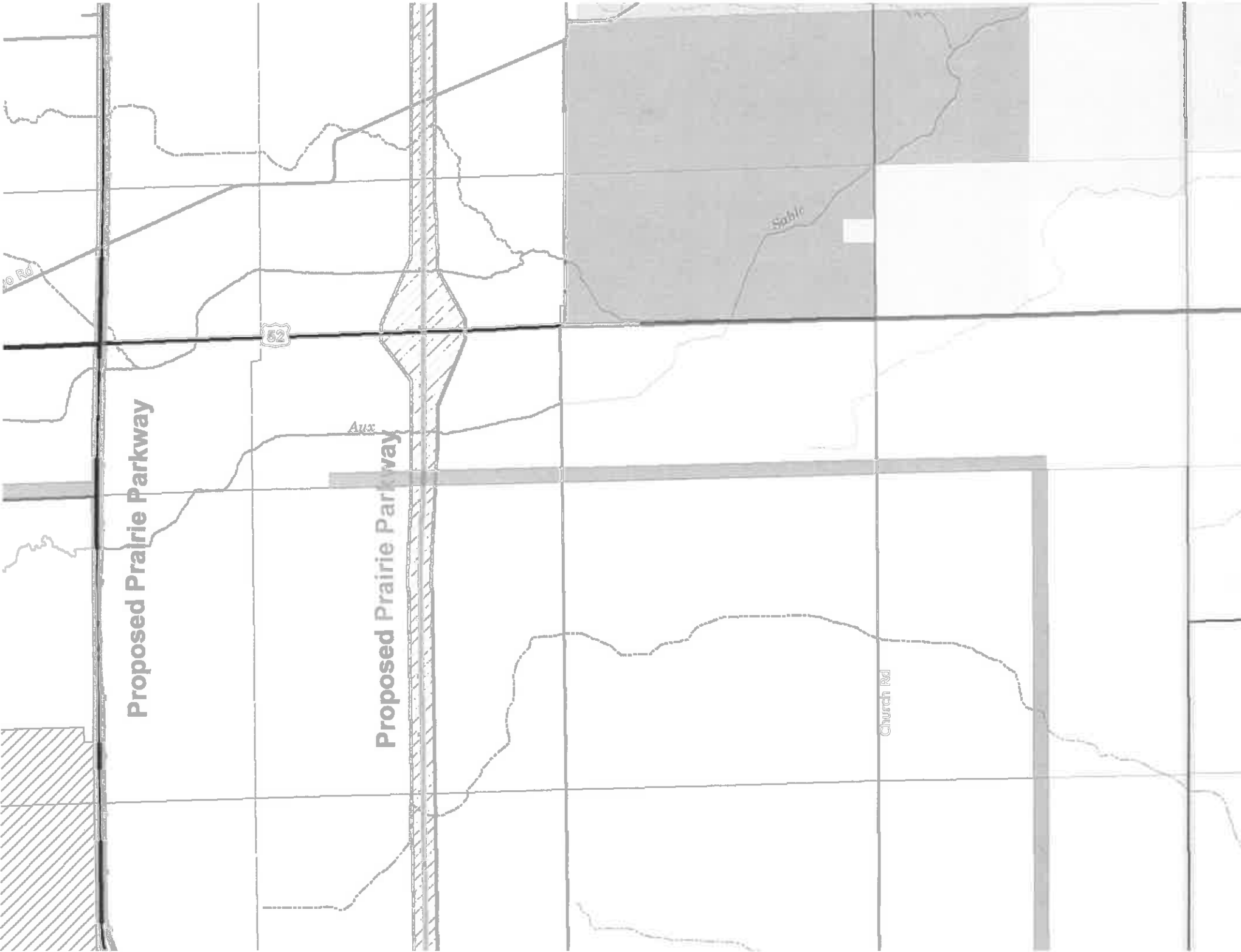

Proposed Parkway

Proposed Parkway

10 Rd

52

Aux

Sable

Church Rd

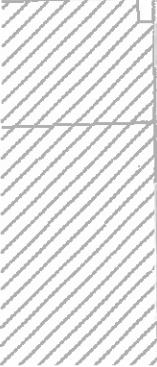

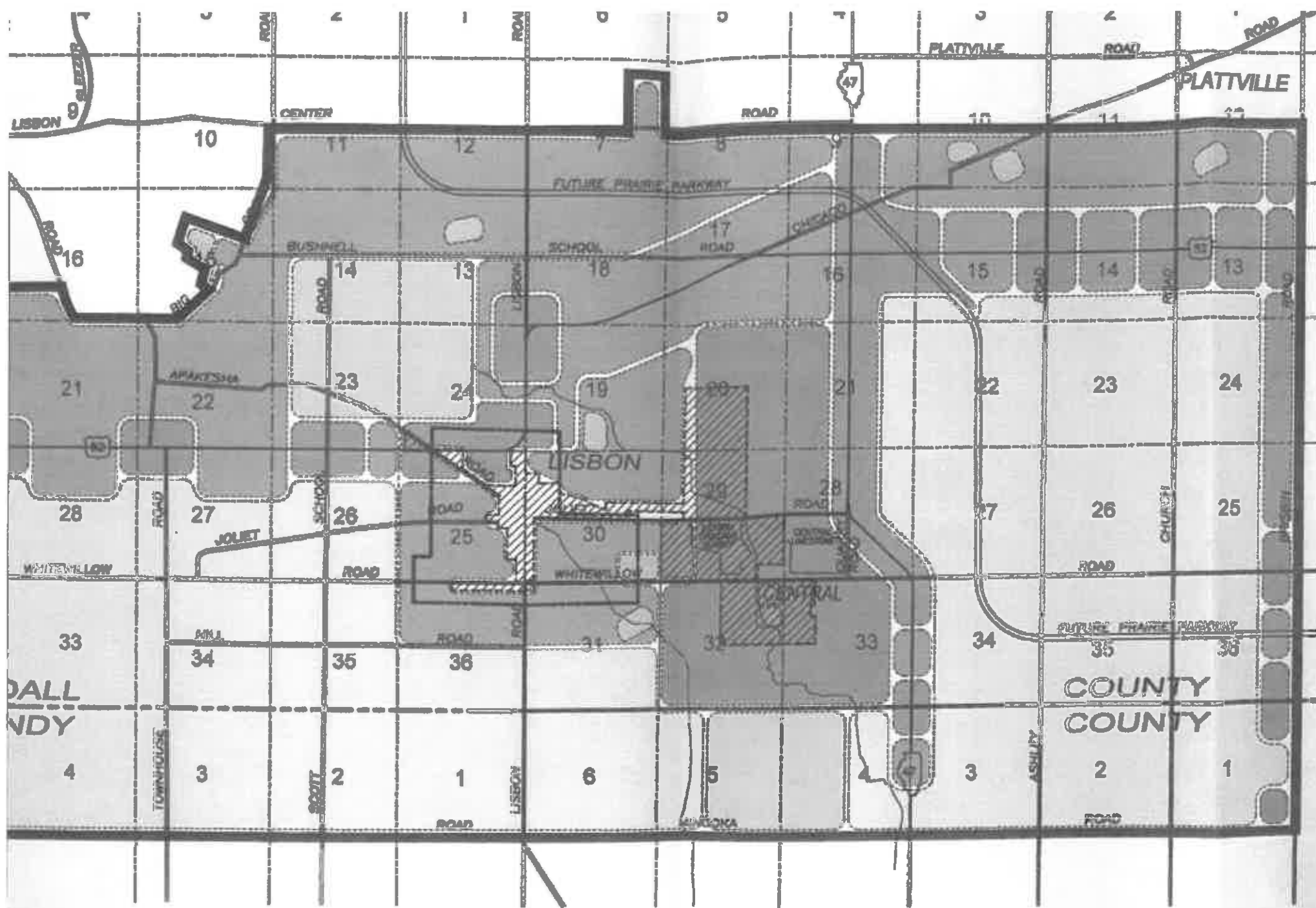

RANGE 8 EAST RANGE 7 EAST

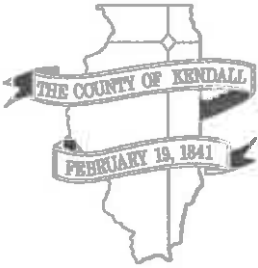

DEPARTMENT OF PLANNING, BUILDING & ZONING
111 West Fox Street • Room 204
Yorkville, IL • 60560
(630) 553-4141 Fax (630) 553-4179
MEMORANDUM

To: Kendall County Committee of the Whole
From: Matthew H. Asselmeier, AICP, Senior Planner
Date: September 11, 2018
Re: 18-13 Proposed Text Amendments Pertaining to Solar Panel Zoning Regulations

At their meeting on March 12, 2018, the Planning, Building and Zoning Committee approved initiating text amendments to the Kendall County Zoning Ordinance incorporating DeKalb County's proposed solar panel regulations into the Kendall County Zoning Ordinance.

The amendment worksheet is attached to this memo.

Mr. Holdiman previously suggested that 4.18.O.2 be removed from the proposal because the County currently does not require insurance for existing solar panels.

The Kendall County Farm Bureau was sent the proposal in March. They questioned why the bonding requirement was "may" and not "shall" (4.18.P.6).

The townships were mailed the proposal on March 22nd and were notified of the results of the July 30, 2018, Zoning Board of Appeals hearing. To date, no townships have submitted comments.

ZPAC met on the proposal on April 3rd and unanimously recommended approval of the proposal with the following amendments:

1. Section 4.18.D.10 should be removed because the same language is found in 4.18.Q.3.
2. A more detailed contour map with existing vegetation, waterways, wetland boundaries, and FEMA FIRM information in a manner described in the Boone County ordinance should be added to the proposal.
3. The reference to the State of Illinois Uniform Building Code found in Section 4.18.C.8 should be removed.
4. Greater discussion should occur regarding the desire to have solar gardens in residential zoned districts.
5. The word "crops" found in line 7 of 4.18.C.4 should be replaced with the word "vegetation" because crops probably will not be the only plants growing around the solar panels and crops probably will not grow around the solar panels.

The Kendall County Regional Planning Commission met on May 23, 2018, and recommended approval of the proposal with the following changes.

1. The reference to a county solar garden in the definition of "Solar Garden" should be deleted.

2. All references to waiving the special use permit requirements and setback requirements should be deleted.
3. Solar gardens and solar farms had to follow the setback requirements for the zoning district in which they are located. Accordingly, the reference to a one hundred foot (100') distance from the right-of-way or property line found in 4.18.D.2 should be deleted.
4. The statement that solar farms require a special use permit found in Section 4.18.D.1 should be removed.
5. If allowed by the State's Attorney's Office, a provision should be added to Section 4.18.F regarding repair of damaged drain tile.

The Kendall County Zoning Board of Appeals held a public hearing on this proposal on July 30, 2018. No members of the public testified in favor or in opposition to the proposal. The Zoning Board of Appeals unanimously recommended approval of the proposal.

The State of Illinois recently approved an Agricultural Impact Mitigation Agreement (AIMA) requirement. This proposal requires decommissioning to be completed within six (6) months of the commencement of the decommissioning plan (4.18.P.4); the AIMA allows a maximum twelve (12) month for decommissioning to occur (17.B). In addition, the proposal gives the County Board discretion whether or not to require a decommissioning bond (4.18.P.6); the AIMA allows decommissioning Financial Assurance to be phased over the first eleven (11) years (17.D).

At their meeting on September 10, 2018, the Planning, Building and Zoning Committee recommended forwarding the proposal to the Committee of the Whole with the decommissioning bond requirement changed from "may" to shall in 4.18.P.6.

The proposal in ordinance form is also attached to this memo.

If you have any questions prior to the meeting on this topic, please let me know.

Thanks,

MHA

ENCS: Worksheet for Solar Panels (Dated 9/11/18)
 Draft Ordinance

Solar Panel Amendments

(Updated 9/11/18)

RED=New Language to the Ordinance

Black=Language Changed by One of the Advisory Committees

Amend Section 3.02 by adding the following terms and definitions:

ACTIVE SOLAR ENERGY SYSTEM. A solar energy system whose primary purpose is to harvest energy by transforming solar energy into another form of energy or transferring heat from a collector to another medium using mechanical, electrical, or chemical means.

BUILDING-INTEGRATED SOLAR ENERGY SYSTEMS. An active solar energy system that is an integral part of a principal or accessory building, rather than a separate mechanical device, replacing or substituting for an architectural or structural component of the building. Building-integrated systems include but are not limited to photovoltaic or hot water solar energy systems that are contained within roofing materials, windows, skylights, and awnings.

GRID-INTERIE SOLAR ENERGY SYSTEM. A photovoltaic solar energy system that is connected to an electric circuit served by an electric utility company.

GROUND MOUNT SOLAR ENERGY SYSTEM. A solar energy system mounted on a rack or pole that rests on or is attached to the ground.

OFF-GRID SOLAR ENERGY SYSTEM. A photovoltaic solar energy system in which the circuits energized by the solar energy system are not electrically connected in any way to electric circuits that are served by an electric utility company.

PASSIVE SOLAR ENERGY SYSTEM. A solar energy system that captures solar light or heat without transforming it to another form of energy or transferring the energy via a heat exchanger.

PHOTOVOLTAIC SYSTEM. An active solar energy system that converts solar energy directly into electricity.

ROOF MOUNT SOLAR ENERGY SYSTEM. A solar energy system that is mounted on a rack that is fastened onto a building roof.

SOLAR ACCESS. Unobstructed access to direct sunlight on a lot or building through the entire year, including access across adjacent parcel air rights, for the purpose of capturing direct sunlight to operate a solar energy system.

SOLAR COLLECTOR. An assembly, structure, and the associated equipment and housing, designed for gathering, concentrating, or absorbing direct and indirect solar energy for which the primary purpose is to convert or transform solar radiant energy into thermal, mechanical, chemical or electrical energy.

SOLAR ENERGY. Radiant energy received from the sun that can be collected in the form of heat or light by a solar collector.

SOLAR ENERGY EASEMENT. An easement that limits the height or location, or both, of permissible development on the burdened land in terms of a structure or vegetation, or both, for the purpose of providing access for the benefited land to wind or sunlight passing over the burdened land.

SOLAR ENERGY SYSTEM (SES). All components required to become a complete assembly or structure that will convert solar energy into electricity for use.

SOLAR ENERGY SYSTEM ADDITION. A private solar energy system which is structurally attached to a building or structure on the zoning lot on which said system is located. Said system shall be considered part of the building and shall comply with all provisions of this ordinance pertaining thereto.

SOLAR ENERGY SYSTEM, PRIVATE. A collection of one (1) or more solar collectors designed for use by the occupant(s) of the zoning lot on which said system is located; excess power generation is limited to net metering or similar technology with regulations set by the local power utility, community, county, and state. Private solar energy system equipment shall conform to applicable industry standards, and applicants for building permits for private solar energy systems shall submit certificates from equipment manufacturers that the equipment is manufactured in compliance with industry standards.

SOLAR FARM. A commercial facility that converts sunlight into electricity, whether by photovoltaics (PV), concentrating solar thermal devices (CST), or other conversion technology, for the primary purpose of wholesale sales of generated electricity. A solar farm is the principal land use for the parcel on which it is located.

SOLAR GARDEN. A commercial solar-electric (photovoltaic) array, of no more than 20 acres in size, that provides retail electric power (or a financial proxy for retail power) to multiple households or businesses ~~residing in or~~ located off-site from the location of the solar energy system. ~~A county solar garden may be either an accessory use, when a part of an existing or a proposed subdivision or a special use if it is a stand-alone garden.~~ (Updated 5/24/18)

SOLAR HEAT EXCHANGER. A component of a solar energy device that is used to transfer heat from one substance to another, either liquid or gas.

SOLAR HOT AIR SYSTEM. An active solar energy system (also referred to as Solar Air Heat or Solar Furnace) that includes a solar collector to provide direct supplemental space heating by heating and re-circulating conditioned building air.

SOLAR HOT WATER SYSTEM. A system (also referred to as Solar Thermal) that includes a solar collector and a heat exchanger that heats or preheats water for building heating systems or other hot water needs, including residential domestic hot water and hot water for commercial processes.

SOLAR MOUNTING DEVICES. Racking, frames, or other devices that allow the mounting of a solar collector onto a roof surface or the ground.

SOLAR STORAGE UNIT. A component of a solar energy device that is used to store solar generated electricity or heat for later use.

Amend Section 4.18 as follows:

4.18 SOLAR PANELS

A. Roof Mounted for On-Site Energy Consumption. Solar panels located on the roof of an existing structure shall be permitted in all districts. Roof mounted solar energy systems shall not extend beyond the exterior perimeter of the building on which the system is mounted. Roof mounted solar energy systems shall not exceed the maximum allowed height in any zoning district. Roof mounted or building integrated private solar energy systems for residential or business use shall be considered an accessory use in all zoning districts where there is a principal structure and shall meet the regulations of the Kendall County Zoning Ordinance. Roof mounted solar panels used as accessory to agricultural uses and which the energy generated from the solar panels is consumed on-site shall be exempt from building permits. **The use of roof mounted solar panels for on-site energy consumption shall comply with all applicable federal, state, and local laws and the rules of the local electrical utility. (Updated 5/14/18)**

B. Freestanding for On-Site Energy Consumption. Solar panels located on the ground or attached to a framework located on the ground shall be classified as accessory structures in all zoning districts provided that the system is no larger than necessary to provide one hundred twenty percent (120%) of the electrical and/or thermal requirements of the structure to which it is accessory as determined by a contractor licensed to install photovoltaic and thermal solar energy systems. Freestanding solar panels shall be permitted if they comply with ~~all of the following standards~~ the standards listed in the Kendall County Zoning Ordinance. Ground or pole mounted solar energy systems shall not exceed the maximum height, when oriented at maximum tilt, for the zoning district in which it is located. Freestanding solar panels used as accessory to agricultural uses **and which the energy generated from the solar panels is**

consumed on-site shall be exempt from building permits. The use of freestanding solar panels for on-site energy consumption shall comply will all applicable federal, state, and local laws and the rules of the local electrical utility. (Updated 5/14/18)

~~(Properties considered agriculturally exempt as defined in State Statute from building permits are further exempt from these standards with the exception of #3 listed below):~~

- ~~1. The proposed system is no larger than necessary to provide 120 percent of the electrical and/or thermal energy requirements of the structure to which it is accessory as determined by a contractor licensed to install photovoltaic and thermal solar energy systems.~~
- ~~2. The solar panels and supporting framework shall not exceed 12' in all districts with the exception of the agricultural district as measured from adjoining grade at base to the highest elevation of the equipment.~~
- ~~3. The solar energy system including any appurtenant equipment is not located within any required setback areas within the respective zoning district.~~
- ~~4. If the solar panels are visible from off-site, the solar panels are not located within 150 feet of a dwelling located on a lot other than the lot on which the solar energy system is located unless:
 - ~~a. There are appropriate facades, walls, fences or landscaping that screen the solar panels and supporting framework from unobstructed view.~~
 - ~~b. Reflection angles from collector surfaces are oriented away from neighboring windows.~~
 - ~~c. The panels are mounted as close as possible to the ground while allowing adequate drainage and preventing vegetation from shading the panels.~~~~
- ~~5. The solar panels are located so that they are not readily visible from public viewing areas including parks, roads and trails located to the south of the site.~~

C. Solar Gardens. Solar gardens shall be allowed in all zoning districts and shall require a special use permit whether accessory or principal use of the property subject to the following requirements:

- ~~1. The requirement for a special use permit may be waived, provided the solar garden's owner/lessee obtains and records with the Kendall County Planning, Building and Zoning Department signed and notarized affidavits agreeing that the need for a special use permit be waived from all property~~

~~owners adjoining the zoning lot on which the solar garden is to be located (as determined by the Kendall County Planning, Building and Zoning Department). (Updated 5/24/18)~~

2. Unless otherwise noted in the Kendall County Zoning Ordinance, solar gardens must comply with all required standards for structures in the district in which the system is located.
 3. Rooftop community systems are permitted in all zoning districts where buildings are permitted.
 4. Ground-mount community solar energy gardens must be less than or equal to twenty (20) acres in total size. Ground-mount solar developments covering more than twenty (20) acres shall be considered solar farms. (Updated 5/14/18)
 5. Solar gardens are subject to Kendall County's Stormwater Management Ordinance and NPDES permit requirements.
 6. An interconnection agreement must be completed with the electric utility in whose service territory the system is located.
 - ~~7. For solar gardens located within 500 feet of an airport or within the approach zones of an airport, the applicant must complete and provide the results of the Solar Glare Hazard Analysis Tool (SGHAT) for the Airport Traffic Control Tower cab and final approach paths, consistent with the Interim Policy, FAA Review of Solar Energy Projects on Federally Obligated Airports, or most recent version adopted by the FAA. (Updated 5/14/18)~~
 8. Ground-mount systems must comply with all required standards for structures in the district in which the system is located. All solar gardens shall also be in compliance with all applicable local, state and federal regulatory codes, including the ~~State of Illinois Uniform Building Code, as amended,~~ and the National Electric Code, as amended. Also, Health Department requirements for wells and septic systems must be met. (Updated 5/14/18).
- D. Solar Farms. Ground-mount solar energy systems that are the primary use on the lot, designed for providing energy to off-site uses or export to the wholesale market are permitted under the following standards:
- ~~1. Solar farms shall require a special use permit in the A-1 Agricultural District. Unless otherwise noted in the Kendall County Zoning Ordinance, solar farms must comply with all the required standards for structures in the district in which the system is located. (Updated 5/24/18)~~

- 2. ~~The solar array and all components of the solar collector system in a solar farm shall be kept at least one hundred feet (100') from a property line or right of way. However, this requirement may be waived, provided the solar farm's owner/lessee obtains, and records with the Kendall County Planning, Building and Zoning Department, signed and notarized affidavits agreeing that the minimum setback be waived, from all property owners and affected road authorities adjoining the zoning lot on which the solar farm is to be located (as determined by the Kendall County, Planning, Building and Zoning Department). However, in no instance shall any part of the solar farm be located within fifty feet (50') of any of the aforementioned items. Unless otherwise noted in the Kendall County Zoning Ordinance, solar farms must comply with all required standards for structures in the district in which the system is located. (Updated 5/24/18)~~**
- 3. Solar farms are subject to Kendall County's Stormwater Management Ordinance and NPDES permit requirements.**
- 4. Top soils shall not be removed during development, unless part of a remediation effort. Soils shall be planted to and maintained in perennial vegetation to prevent erosion, manage run off and build soil. A plan must be approved by the Kendall County Soil and Water Conservation District and paid for by the developer. Applicable noxious weed ordinances shall be followed. Due to potential County liability under the Illinois Endangered Species Protection Act (520 ILCS 10/11(b)), it is required that any crops or vegetation planted be in compliance with all federal and state laws protecting endangered species. This will also include pollinators such as bees. A report showing demonstration of plan compliance shall be submitted annually and paid for by the developer. (Updated 5/14/18)**
- 5. A qualified engineer shall certify that the foundation and design of the solar panels racking and support is within accepted professional standards, given local soil and climate conditions.**
- 6. All solar farms shall be in compliance with all applicable local, state and federal regulatory codes and the National Electric Code, as amended.**
- 7. Power and communication lines running between banks of solar panels and to nearby electric substations or interconnections with buildings shall be buried underground. Exemptions may be granted by Kendall County in instances where shallow bedrock, water courses, or other elements of the natural landscape interfere with the ability to bury lines or distance makes undergrounding infeasible, at the discretion of the Kendall County Planning, Building and Zoning Department. In addition, the Illinois Department of Agriculture (IDOA) has established standards and policies in the Agricultural Impact Mitigation Agreements (AIMA) regarding the**

construction or burial of electric transmission lines which should be agreed to and adhered to between the landowner and the developer.

8. A detailed site plan for both existing and proposed conditions must be submitted, showing location of all solar arrays, other structures, property lines, rights-of-way, service roads, floodplains, wetlands and other protected natural resources, topography, farm tile, electric equipment, fencing, and screening materials and all other characteristics requested by Kendall County. The site plan should also show all zoning districts and overlay districts.

~~9. For solar farms located within five hundred feet (500') of an airport or within approach zones of an airport, the applicant must complete and provide the results of the Solar Glare Hazard Analysis Tool (SGHAT) for the Airport Traffic Control Tower cab and final approach paths, consistent with the Interim Policy, FAA Review of Solar Energy Projects on Federally Obligated Airports, or most recent version adopted by the FAA. (Updated 5/14/18)~~

~~10. Solar farm developers shall be required to initiate a natural resource review consultation with the Illinois Department of Natural Resources (IDNR) through the department's online, EcoCat program. Areas reviewed through this process will be endangered species and wetlands. The cost of the EcoCat consultation will be borne by the developer. (Updated 5/14/18)~~

- E. Setback Requirements. Unless otherwise stated in the Kendall County Zoning Ordinance, the setback requirements for all solar energy systems shall meet the structure minimum setback requirements when the solar energy system is oriented at any and all positions.

No solar energy system shall be located in any front yard of any residentially zoned or used property.

- F. Design Standards. Active solar energy systems shall be designed to conform to the County's Land Resource Management Plan and to blend into the architecture of the building or may be required to be screened from the routine view from public rights-of-way other than alleys. Screening may be required to the extent it does not affect the operation of the system. The color of the solar collector is not required to be consistent with other roofing materials.

1. Building integrated photovoltaic solar energy systems shall be allowed regardless of whether the system is visible from the public right-of-way, provided the building component in which the system is integrated meets all required setback, land use or performance standards for the district in which the building is located.

2. **Solar energy systems using roof mounting devices or ground-mount solar energy systems shall not be restricted if the system is not visible from the closest edge of any public right-of-way or immediately adjacent to a residential structure.**
 3. **All solar energy systems using a reflector to enhance solar production shall minimize glare from the reflector affecting adjacent or nearby properties. Measures to minimize glare include selective placement of the system, screening on the north side of the solar array, modifying the orientation of the system, reducing use of the reflector system, or other remedies that limit glare.**
 4. **Damaged field drain tile shall be repaired or rerouted on a timetable approved by the Kendall County Planning, Building and Zoning Department. (Updated 5/24/18)**
 - ~~5. **For solar units located within 500 feet of an airport or within approach zones of an airport, the applicant must complete and provide the results of the Solar Glare Hazard Analysis Tool (SGHAT) for the Airport Traffic Control Tower cab and final approach paths, consistent with the Interim Policy, FAA Review of Solar Energy Projects on Federally Obligated Airports, or most recent version adopted by the FAA. (Updated 5/14/18)**~~
- G. **Coverage. Roof or building mounted solar energy systems, excluding building-integrated systems, shall allow for adequate roof access for fire-fighting purposes to the south-facing or flat roof upon which the panels are mounted. Ground-mount private solar energy systems shall be exempt from impervious surface calculations if the soil under the collector is not compacted and maintained in vegetation. Foundations, gravel, or compacted soils are considered impervious.**
- H. **Plan Approval Required. All solar energy systems shall require administrative plan approval by the Kendall County Building Official via the review of the application for a building permit.**
1. **Plan applications for solar energy systems shall be accompanied by horizontal and vertical (elevation) drawings. The drawings must show the location of the system on the building or on the property for a ground-mount system including the property lines.**
 2. **For all roof-mounted systems other than a flat roof, the elevation must show the highest finished slope of the solar collector and the slope of the finished roof surface on which it is mounted.**
 3. **For flat roof applications, a drawing shall be submitted showing the distance to the roof edge and any parapets on the building shall identify**

the height of the building on the street frontage side, the shortest distance of the system from the street frontage edge of the building, and the highest finished height of the solar collector above the finished surface of the roof.

4. Applications that meet the design requirements of the Kendall County Zoning Ordinance and do not require an administrative variance shall be granted administrative approval by the Zoning Administrator and not require Planning, Building and Zoning Committee review. Plan approval does not indicate compliance with Building or Electrical Codes.
- I. **Approved Solar Components.** Electric solar energy system components must have a UL listing approved equivalent and solar hot water systems must have an SRCC rating.
- J. **Compliance with Building Code.** All active solar energy systems shall meet approval of County building officials; solar thermal systems shall comply with HVAC-related requirements of the Illinois State Energy Code. All County adopted building codes will apply and take precedence where applicable.
- ~~K. **Compliance with State Plumbing Code.** Solar thermal systems shall comply with applicable Illinois State Plumbing Code requirements. (Updated 5/14/18)~~
- ~~L. **Compliance with State Energy Code.** All photovoltaic systems and solar thermal systems shall comply with the Illinois State Energy Code. (Updated 5/14/18)~~
- M. **Utility Notification.** All grid-intertie solar energy systems shall comply with the interconnection requirements of the electric utility. Off-grid systems are exempt from this requirement.
- N. **Building Permit Requirements and Fees.** All solar energy systems will be required to have a Kendall County Building Permit before any work can be started. A written plan and a plat/drawing for the proposed solar energy system shall be provided with the Building Permit Application. The plat/drawing must show the location of the system on the building or on the property, (for a ground-mount system show arrangement of panels), with all property lines and set back footages indicated. Fees for processing the applications for building permits shall be submitted to and collected by the Kendall County Planning, Building and Zoning Department as follows:

0-	10 kilowatts (kW)	\$150.00
11-	50 kilowatts (kW)	\$300.00
51-	100 kilowatts (kW)	\$600.00
101-	500 kilowatts (kW)	\$1,200.00
501-	1,000 kilowatts (kW)	\$2,750.00
1,001-	2,000 kilowatts (kW)	\$6,000.00

Over 2,000 kilowatts (kW) \$6,000.00 + \$200.00 for each additional 0-100 kilowatts

Any solar energy system that construction has started before a Building Permit has been applied and paid for will be charged double the permit fee. The above fees do not apply to solar energy systems used to generate energy for on-site consumption of energy for agricultural purposes. (Updated 5/14/18)

O. Liability Insurance and Indemnification.

- 1. For Solar Farms and Solar Gardens, commencing with the issuance of building permits, the Applicant, Owner, or Operator shall maintain a current general liability policy covering bodily injury and property damage with limits of at least Three Million Dollars (\$3 Million) per occurrence and Five Million Dollars (\$5 Million) in the aggregate. Such insurance may be provided pursuant to a plan of self- insurance, by a party with a net worth of Twenty Million Dollars (\$20 Million) or more. The County shall be named as an individual insured on the policy to the extent the county is entitled to indemnification.**
- ~~2. For private/individual SES(s), commencing with the issuance of building permits, the applicant or owner shall maintain a current liability policy covering bodily injuries and any damage that may occur, on their home owner's policy or other applicable policy as approved by the Planning, Building and Zoning Department. (Remove Per Brian Holdiman)~~**
- 3. Any SES(s), applicant, owner, or operator, whether individual or commercial, shall defend, indemnify, and hold harmless the County and its officials, employees, and agents (collectively and individually, the "Indemnified Parties") from and against any and all claims, demands, losses, suits, causes of actions, damages, injuries, costs, expenses, and liabilities whatsoever, including reasonable attorney's fees, except to the extent arising in whole or part out of negligence or intentional acts of such Indemnified Parties (such liabilities together known as "liability") arising out of applicant, owner, or operators selection, construction, operation, and removal of the SES(s) and affiliated equipment including, without limitation, liability for property damage or personal injury (including death), whether said liability is premised on contract or on tort (including without limitation strict liability or negligence). This general indemnification shall not be construed as limited or qualifying the County's other indemnification rights available under the law.**

P. Decommissioning Plan.

- 1. Upon the request of the Kendall County Planning, Building and Zoning Department, an owner of a ~~commercial~~ solar energy system must provide**

documentation, within thirty (30) days, that the solar energy system is still in use. If the solar energy system is not in use, the owner of the system shall have 180 days, after notification from the Kendall County Planning, Building and Zoning Department, to remove the solar energy system from the property. (Updated 5/14/18)

2. A decommissioning plan shall be required at the time of applying for all solar farms and solar gardens to ensure that the facilities are properly removed after their useful life.
3. Decommission of solar panels must occur in the event they are not in use for ninety (90) consecutive days.
4. The owner or operator will have six (6) months to complete the decommissioning plan after operation of a solar farm or solar garden ceases.
5. The decommissioning plan shall include provisions for removal of all structures and foundations, restoration of soil and vegetation, and a plan ensuring financial resources will be available to fully decommission the site.
6. The Kendall County Board ~~may~~ **shall** require the posting of a bond, letter of credit, or the establishment of an escrow account to ensure the proper decommissioning. The posting of a bond may be required prior to the issuance of a building permit for the facility. (Updated 9/10/18)
7. In the event that the State of Illinois enacts a law with regards to the decommissioning of a solar farm, the strictest requirements shall prevail.

Q. Other Requirements.

- ~~1. Upon request from the Kendall County Planning, Building and Zoning Department, an owner of a commercial solar energy system must provide documentation, within thirty (30) calendar days, that the solar energy system is still in use. If it is not still in use, the owner of the system will have one hundred eighty (180) calendar days, after notification from the Planning, Building and Zoning Department, to remove the solar energy system from the property. (Updated 5/14/18)~~
2. Upon request from the Kendall County Planning, Building and Zoning Department, the owner or operator of a solar farm or a solar garden must submit, within fourteen (14) calendar days, a current operation and maintenance report to the Department.

3. In all undeveloped areas, the solar energy developer will be required to complete a consultation with both the Illinois Historic Preservation Agency (IHPA) and the Illinois Department of Natural Resources (IDNR) through the Department's online EcoCat Program. The cost of this consultation shall be at the developer's expense. The final certificate from EcoCat shall be provided to the Kendall County Planning, Building and Zoning Department before a permit or special use permit will be issued.
4. No fencing is required; however, if installed on the property the fencing shall have a maximum height of eight (8) feet. The fence shall contain appropriate warning signage that is posted such that is clearly visible on the site.
5. Any lighting for solar farms or solar gardens shall be installed for security and safety purposes only. Except for lighting that is required by the FCC or FAA, all lighting shall be shielded so that no glare extends substantially beyond the boundaries of the facility.
6. Reflection angles for solar collectors shall be oriented such that they do not project glare onto adjacent properties.
7. Electric solar energy system components must have a UL listing and must be designed with anti-reflective coating(s).
8. Solar energy systems must be in compliance with all State of Illinois Plumbing and Energy Codes.
9. For solar energy systems located within five hundred feet (500') of an airport or within approach zones of an airport, the applicant must complete and provide the results of the Solar Glare Hazard Analysis Tool (SGHAT) for the Airport Traffic Control Tower cab and final approach paths, consistent with the Interim Policy, FAA Review of Solar Energy Projects on Federally Obligated Airports, or most recent version adopted by the FAA (Updated 5/14/18).

Amend Section 7.01.D by adding:

"54. Solar Gardens subject to the provisions of Section 4.00 of the Kendall County Zoning Ordinance.

55. Solar Farms subject to the provisions of Section 4.00 of the Kendall County Zoning Ordinance."

Amend Section 8.02.C by adding:

“19. Solar Gardens subject to the provisions of Section 4.00 of the Kendall County Zoning Ordinance.”

Amend Section 8.03.H.1 by adding

“p. Solar Gardens subject to the provisions of Section 4.00 of the Kendall County Zoning Ordinance.”

Amend Section 8.09.B by adding

“9. Solar Gardens subject to the provisions of Section 4.00 of the Kendall County Zoning Ordinance.”

Amend Section 9.02.C

“15. Solar Gardens subject to the provisions of Section 4.00 of the Kendall County Zoning Ordinance.”

Amend Section 9.03.C

“26. Solar Gardens subject to the provisions of Section 4.00 of the Kendall County Zoning Ordinance.”

Amend Section 9.04.C

“29. Solar Gardens subject to the provisions of Section 4.00 of the Kendall County Zoning Ordinance.”

Amend Section 9.05.C

“20. Solar Gardens subject to the provisions of Section 4.00 of the Kendall County Zoning Ordinance.”

Amend Section 9.06.F

“Solar Gardens. Solar gardens shall be a special use in the B-5 Business Planned Development District.

Amend Section 9.07.C

“19. Solar Gardens subject to the provisions of Section 4.00 of the Kendall County Zoning Ordinance.”

Amend Section 10.03.B

“5. Solar Gardens subject to the provisions of Section 4.00 of the Kendall County Zoning Ordinance.”

Amend the Table of Uses to reflect Solar Gardens as special use in every zoning district and Solar Farms as a special use in the A-1 District.

ORDINANCE NUMBER 2018-_____

TEXT AMENDMENT TO SECTIONS 3.02, 4.18, 7.01.D, 8.02.C 8.03.H.1, 8.09.B, 9.02.C, 9.03.C, 9.04.C, 9.05.C, 9.06.F, 9.07.C, AND 10.03.B OF THE KENDALL COUNTY ZONING ORDINANCE BY AMENDING KENDALL COUNTY'S SOLAR PANEL ZONING REGULATIONS

WHEREAS, Section 13.07 of the Kendall County Zoning Ordinance permits the Kendall County Board to approve text amendments and provides the procedure through which text amendments are granted; and

WHEREAS, Section 13.08 of the Kendall County Zoning Ordinance contains the procedures for approving special use permits, major and minor amendments to special use permits, and revocations of special use permits, but does not contain specific procedures for the renewal of special use permits;

WHEREAS, on March 12, 2018, the Kendall County Planning, Building and Zoning Committee, hereinafter be referred to as "Petitioner", submitted a text amendment to the Kendall County Zoning Ordinance amending Kendall County's Solar Panel Zoning Regulations; and

WHEREAS, following due and proper notice by publication in the Kendall County Record on July 12, 2018, the Kendall County Zoning Board of Appeals conducted a public hearing on July 30, 2018, at 7:00 p.m., in the County Office Building at 111 W. Fox Street in Yorkville, at which the Petitioner and the Petitioner's representative presented evidence, testimony, and exhibits in support of the requested text amendment and zero members of the public asked questions or testified in favor or testified in opposition to the request; and

WHEREAS, based on the evidence, testimony, and exhibits, the Kendall County Zoning Board of Appeals has recommended approval of the text amendment on July 30, 2018; and

WHEREAS, the Kendall County Planning, Building and Zoning Committee of the Kendall County Board has reviewed the testimony presented at the aforementioned public hearing, and has forwarded to the Kendall County Board a recommendation of approval of the requested text amendment; and

WHEREAS, the Kendall County Board has considered the recommendations of the Planning, Building and Zoning Committee and the Kendall County Zoning Board of Appeals, and has determined that said petition is in conformance with the provisions and intent of the Kendall County Zoning Ordinance; and

NOW, THEREFORE, BE IT ORDAINED, BY THE COUNTY BOARD OF KENDALL COUNTY, ILLINOIS, that the Kendall County Zoning Ordinance be amended as follows:

- I. Recitals: The recitals set forth above are incorporated as if fully set forth herein.
- II. Amended Text: Section 3.02 is amended by adding the following terms and definitions:

“ACTIVE SOLAR ENERGY SYSTEM. A solar energy system whose primary purpose is to harvest energy by transforming solar energy into another form of energy or transferring heat from a collector to another medium using mechanical, electrical, or chemical means.

BUILDING-INTEGRATED SOLAR ENERGY SYSTEMS. An active solar energy system that is an integral part of a principal or accessory building, rather than a separate mechanical device, replacing or

substituting for an architectural or structural component of the building. Building-integrated systems include but are not limited to photovoltaic or hot water solar energy systems that are contained within roofing materials, windows, skylights, and awnings.

GRID-INTERIE SOLAR ENERGY SYSTEM. A photovoltaic solar energy system that is connected to an electric circuit served by an electric utility company.

GROUND MOUNT SOLAR ENERGY SYSTEM. A solar energy system mounted on a rack or pole that rests on or is attached to the ground.

OFF-GRID SOLAR ENERGY SYSTEM. A photovoltaic solar energy system in which the circuits energized by the solar energy system are not electrically connected in any way to electric circuits that are served by an electric utility company.

PASSIVE SOLAR ENERGY SYSTEM. A solar energy system that captures solar light or heat without transforming it to another form of energy or transferring the energy via a heat exchanger.

PHOTOVOLTAIC SYSTEM. An active solar energy system that converts solar energy directly into electricity.

ROOF MOUNT SOLAR ENERGY SYSTEM. A solar energy system that is mounted on a rack that is fastened onto a building roof.

SOLAR ACCESS. Unobstructed access to direct sunlight on a lot or building through the entire year, including access across adjacent parcel air rights, for the purpose of capturing direct sunlight to operate a solar energy system.

SOLAR COLLECTOR. An assembly, structure, and the associated equipment and housing, designed for gathering, concentrating, or absorbing direct and indirect solar energy for which the primary purpose is to convert or transform solar radiant energy into thermal, mechanical, chemical or electrical energy.

SOLAR ENERGY. Radiant energy received from the sun that can be collected in the form of heat or light by a solar collector.

SOLAR ENERGY EASEMENT. An easement that limits the height or location, or both, of permissible development on the burdened land in terms of a structure or vegetation, or both, for the purpose of providing access for the benefited land to wind or sunlight passing over the burdened land.

SOLAR ENERGY SYSTEM (SES). All components required to become a complete assembly or structure that will convert solar energy into electricity for use.

SOLAR ENERGY SYSTEM ADDITION. A private solar energy system which is structurally attached to a building or structure on the zoning lot on which said system is located. Said system shall be considered part of the building and shall comply with all provisions of this ordinance pertaining thereto.

SOLAR ENERGY SYSTEM, PRIVATE. A collection of one (1) or more solar collectors designed for use by the occupant(s) of the zoning lot on which said system is located; excess power generation is limited to net metering or similar technology with regulations set by the local power utility,

community, county, and state. Private solar energy system equipment shall conform to applicable industry standards, and applicants for building permits for private solar energy systems shall submit certificates from equipment manufacturers that the equipment is manufactured in compliance with industry standards.

SOLAR FARM. A commercial facility that converts sunlight into electricity, whether by photovoltaics (PV), concentrating solar thermal devices (CST), or other conversion technology, for the primary purpose of wholesale sales of generated electricity. A solar farm is the principal land use for the parcel on which it is located.

SOLAR GARDEN. A commercial solar-electric (photovoltaic) array, of no more than 20 acres in size, that provides retail electric power (or a financial proxy for retail power) to multiple households or businesses located off-site from the location of the solar energy system.

SOLAR HEAT EXCHANGER. A component of a solar energy device that is used to transfer heat from one substance to another, either liquid or gas.

SOLAR HOT AIR SYSTEM. An active solar energy system (also referred to as Solar Air Heat or Solar Furnace) that includes a solar collector to provide direct supplemental space heating by heating and re-circulating conditioned building air.

SOLAR HOT WATER SYSTEM. A system (also referred to as Solar Thermal) that includes a solar collector and a heat exchanger that heats or preheats water for building heating systems or other hot water needs, including residential domestic hot water and hot water for commercial processes.

SOLAR MOUNTING DEVICES. Racking, frames, or other devices that allow the mounting of a solar collector onto a roof surface or the ground.

SOLAR STORAGE UNIT. A component of a solar energy device that is used to store solar generated electricity or heat for later use.”

III. Amended Text: Section 4.18 is hereby deleted in its entirety and replaced with the following:

“A. **Roof Mounted for On-Site Energy Consumption.** Solar panels located on the roof of an existing structure shall be permitted in all districts. Roof mounted solar energy systems shall not extend beyond the exterior perimeter of the building on which the system is mounted. Roof mounted solar energy systems shall not exceed the maximum allowed height in any zoning district. Roof mounted or building integrated private solar energy systems for residential or business use shall be considered an accessory use in all zoning districts where there is a principal structure and shall meet the regulations of the Kendall County Zoning Ordinance. Roof mounted solar panels used as accessory to agricultural uses and which the energy generated from the solar panels is consumed on-site shall be exempt from building permits. The use of roof mounted solar panels for on-site energy consumption shall comply with all applicable federal, state, and local laws and the rules of the local electrical utility.

B. **Freestanding for On-Site Energy Consumption.** Solar panels located on the ground or attached to a framework located on the ground shall be classified as accessory structures in all zoning districts provided that the system is no larger than necessary to provide one hundred twenty percent (120%) of the electrical and/or thermal requirements of the structure to which it is accessory as determined by a contractor licensed to install photovoltaic and thermal solar energy systems. Freestanding solar panels

shall be permitted if they comply with the standards listed in the Kendall County Zoning Ordinance. Ground or pole mounted solar energy systems shall not exceed the maximum height, when oriented at maximum tilt, for the zoning district in which it is located. Freestanding solar panels used as accessory to agricultural uses and which the energy generated from the solar panels is consumed on-site shall be exempt from building permits. The use of freestanding solar panels for on-site energy consumption shall comply will all applicable federal, state, and local laws and the rules of the local electrical utility.

C. Solar Gardens. Solar gardens shall be allowed in all zoning districts and shall require a special use permit whether accessory or principal use of the property subject to the following requirements:

1. Unless otherwise noted in the Kendall County Zoning Ordinance, solar gardens must comply with all required standards for structures in the district in which the system is located.
2. Rooftop community systems are permitted in all zoning districts where buildings are permitted.
3. Ground-mount community solar energy gardens must be less than or equal to twenty (20) acres in total size. Ground-mount solar developments covering more than twenty (20) acres shall be considered solar farms.
4. Solar gardens are subject to Kendall County's Stormwater Management Ordinance and NPDES permit requirements.
5. An interconnection agreement must be completed with the electric utility in whose service territory the system is located.
6. Ground-mount systems must comply with all required standards for structures in the district in which the system is located. All solar gardens shall also be in compliance with all applicable local, state and federal regulatory codes, including the National Electric Code, as amended. Also, Health Department requirements for wells and septic systems must be met.

D. Solar Farms. Ground-mount solar energy systems that are the primary use on the lot, designed for providing energy to off-site uses or export to the wholesale market are permitted under the following standards:

1. Unless otherwise noted in the Kendall County Zoning Ordinance, solar farms must comply with all required standards for structures in the district in which the system is located.
2. Solar farms are subject to Kendall County's Stormwater Management Ordinance and NPDES permit requirements.
3. Top soils shall not be removed during development, unless part of a remediation effort. Soils shall be planted to and maintained in perennial vegetation to prevent erosion, manage run off and build soil. A plan must be approved by the Kendall County Soil and Water Conservation District and paid for by the developer. Applicable noxious weed ordinances shall be followed. Due to potential County liability under the Illinois Endangered Species Protection Act (520 ILCS 10/11(b)), it is required that any crops or vegetation planted be in compliance with all federal and state laws protecting endangered species. This will also include

pollinators such as bees. A report showing demonstration of plan compliance shall be submitted annually and paid for by the developer.

4. A qualified engineer shall certify that the foundation and design of the solar panels racking and support is within accepted professional standards, given local soil and climate conditions.
5. All solar farms shall be in compliance with all applicable local, state and federal regulatory codes and the National Electric Code, as amended.
6. Power and communication lines running between banks of solar panels and to nearby electric substations or interconnections with buildings shall be buried underground. Exemptions may be granted by Kendall County in instances where shallow bedrock, water courses, or other elements of the natural landscape interfere with the ability to bury lines or distance makes undergrounding infeasible, at the discretion of the Kendall County Planning, Building and Zoning Department. In addition, the Illinois Department of Agriculture (IDOA) has established standards and policies in the Agricultural Impact Mitigation Agreements (AIMA) regarding the construction or burial of electric transmission lines which should be agreed to and adhered to between the landowner and the developer.
7. A detailed site plan for both existing and proposed conditions must be submitted, showing location of all solar arrays, other structures, property lines, rights-of-way, service roads, floodplains, wetlands and other protected natural resources, topography, farm tile, electric equipment, fencing, and screening materials and all other characteristics requested by Kendall County. The site plan should also show all zoning districts and overlay districts.

E. Setback Requirements. Unless otherwise stated in the Kendall County Zoning Ordinance, the setback requirements for all solar energy systems shall meet the structure minimum setback requirements when the solar energy system is oriented at any and all positions.

No solar energy system shall be located in any front yard of any residentially zoned or used property.

F. Design Standards. Active solar energy systems shall be designed to conform to the County's Land Resource Management Plan and to blend into the architecture of the building or may be required to be screened from the routine view from public rights-of-way other than alleys. Screening may be required to the extent it does not affect the operation of the system. The color of the solar collector is not required to be consistent with other roofing materials.

1. Building integrated photovoltaic solar energy systems shall be allowed regardless of whether the system is visible from the public right-of-way, provided the building component in which the system is integrated meets all required setback, land use or performance standards for the district in which the building is located.
2. Solar energy systems using roof mounting devices or ground-mount solar energy systems shall not be restricted if the system is not visible from the closest edge of any public right-of-way or immediately adjacent to a residential structure.
3. All solar energy systems using a reflector to enhance solar production shall minimize glare from the reflector affecting adjacent or nearby properties. Measures to minimize glare include selective placement of the system, screening on the north side of the solar array, modifying the

orientation of the system, reducing use of the reflector system, or other remedies that limit glare.

4. Damaged field drain tile shall be repaired or rerouted on a timetable approved by the Kendall County Planning, Building and Zoning Department.

G. Coverage. Roof or building mounted solar energy systems, excluding building-integrated systems, shall allow for adequate roof access for fire-fighting purposes to the south-facing or flat roof upon which the panels are mounted. Ground-mount private solar energy systems shall be exempt from impervious surface calculations if the soil under the collector is not compacted and maintained in vegetation. Foundations, gravel, or compacted soils are considered impervious.

H. Plan Approval Required. All solar energy systems shall require administrative plan approval by the Kendall County Building Official via the review of the application for a building permit.

1. Plan applications for solar energy systems shall be accompanied by horizontal and vertical (elevation) drawings. The drawings must show the location of the system on the building or on the property for a ground-mount system including the property lines.
2. For all roof-mounted systems other than a flat roof, the elevation must show the highest finished slope of the solar collector and the slope of the finished roof surface on which it is mounted.
3. For flat roof applications, a drawing shall be submitted showing the distance to the roof edge and any parapets on the building shall identify the height of the building on the street frontage side, the shortest distance of the system from the street frontage edge of the building, and the highest finished height of the solar collector above the finished surface of the roof.
4. Applications that meet the design requirements of the Kendall County Zoning Ordinance and do not require an administrative variance shall be granted administrative approval by the Zoning Administrator and not require Planning, Building and Zoning Committee review. Plan approval does not indicate compliance with Building or Electrical Codes.

I. Approved Solar Components. Electric solar energy system components must have a UL listing approved equivalent and solar hot water systems must have an SRCC rating.

J. Compliance with Building Code. All active solar energy systems shall meet approval of County building officials; solar thermal systems shall comply with HVAC-related requirements of the Illinois State Energy Code. All County adopted building codes will apply and take precedence where applicable.

K. Utility Notification. All grid-intertie solar energy systems shall comply with the interconnection requirements of the electric utility. Off-grid systems are exempt from this requirement.

L. Building Permit Requirements and Fees. All solar energy systems will be required to have a Kendall County Building Permit before any work can be started. A written plan and a plat/drawing for the proposed solar energy system shall be provided with the Building Permit Application. The plat/drawing must show the location of the system on the building or on the property, (for a ground-mount system show arrangement of panels), with all property lines and set back footages indicated.

Fees for processing the applications for building permits shall be submitted to and collected by the Kendall County Planning, Building and Zoning Department as follows:

0-	10 kilowatts (kW)	\$150.00
11-	50 kilowatts (kW)	\$300.00
51-	100 kilowatts (kW)	\$600.00
101-	500 kilowatts (kW)	\$1,200.00
501-	1,000 kilowatts (kW)	\$2,750.00
1,001-	2,000 kilowatts (kW)	\$6,000.00
	Over 2,000 kilowatts (kW)	\$6,000.00 + \$200.00 for each additional 0-100 kilowatts

Any solar energy system that construction has started before a Building Permit has been applied and paid for will be charged double the permit fee. The above fees do not apply to solar energy systems used to generate energy for on-site consumption of energy for agricultural purposes.

M. Liability Insurance and Indemnification.

1. For Solar Farms and Solar Gardens, commencing with the issuance of building permits, the Applicant, Owner, or Operator shall maintain a current general liability policy covering bodily injury and property damage with limits of at least Three Million Dollars (\$3 Million) per occurrence and Five Million Dollars (\$5 Million) in the aggregate. Such insurance may be provided pursuant to a plan of self-insurance, by a party with a net worth of Twenty Million Dollars (\$20 Million) or more. The County shall be named as an individual insured on the policy to the extent the county is entitled to indemnification.
2. Any SES(s), applicant, owner, or operator, whether individual or commercial, shall defend, indemnify, and hold harmless the County and its officials, employees, and agents (collectively and individually, the "Indemnified Parties") from and against any and all claims, demands, losses, suits, causes of actions, damages, injuries, costs, expenses, and liabilities whatsoever, including reasonable attorney's fees, except to the extent arising in whole or part out of negligence or intentional acts of such Indemnified Parties (such liabilities together known as "liability") arising out of applicant, owner, or operators selection, construction, operation, and removal of the SES(s) and affiliated equipment including, without limitation, liability for property damage or personal injury (including death), whether said liability is premised on contract or on tort (including without limitation strict liability or negligence). This general indemnification shall not be construed as limited or qualifying the County's other indemnification rights available under the law.

N. Decommissioning Plan.

1. Upon the request of the Kendall County Planning, Building and Zoning Department, an owner of a solar energy system must provide documentation, within thirty (30) days, that the solar energy system is still in use. If the solar energy system is not in use, the owner of the system shall have 180 days, after notification from the Kendall County Planning, Building and Zoning Department, to remove the solar energy system from the property.
2. A decommissioning plan shall be required at the time of applying for all solar farms and solar gardens to ensure that the facilities are properly removed after their useful life.

3. Decommission of solar panels must occur in the event they are not in use for ninety (90) consecutive days.
4. The owner or operator will have six (6) months to complete the decommissioning plan after operation of a solar farm or solar garden ceases.
5. The decommissioning plan shall include provisions for removal of all structures and foundations, restoration of soil and vegetation, and a plan ensuring financial resources will be available to fully decommission the site.
6. The Kendall County Board shall require the posting of a bond, letter of credit, or the establishment of an escrow account to ensure the proper decommissioning. The posting of a bond may be required prior to the issuance of a building permit for the facility.
7. In the event that the State of Illinois enacts a law with regards to the decommissioning of a solar farm, the strictest requirements shall prevail.

O. Other Requirements.

1. Upon request from the Kendall County Planning, Building and Zoning Department, the owner or operator of a solar farm or a solar garden must submit, within fourteen (14) calendar days, a current operation and maintenance report to the Department.
2. In all undeveloped areas, the solar energy developer will be required to complete a consultation with both the Illinois Historic Preservation Agency (IHPA) and the Illinois Department of Natural Resources (IDNR) through the Department's online EcoCat Program. The cost of this consultation shall be at the developer's expense. The final certificate from EcoCat shall be provided to the Kendall County Planning, Building and Zoning Department before a permit or special use permit will be issued.
3. No fencing is required; however, if installed on the property the fencing shall have a maximum height of eight (8) feet. The fence shall contain appropriate warning signage that is posted such that is clearly visible on the site.
4. Any lighting for solar farms or solar gardens shall be installed for security and safety purposes only. Except for lighting that is required by the FCC or FAA, all lighting shall be shielded so that no glare extends substantially beyond the boundaries of the facility.
5. Reflection angles for solar collectors shall be oriented such that they do not project glare onto adjacent properties.
6. Electric solar energy system components must have a UL listing and must be designed with anti-reflective coating(s).
7. Solar energy systems must be in compliance with all State of Illinois Plumbing and Energy Codes.
8. For solar energy systems located within five hundred feet (500') of an airport or within approach zones of an airport, the applicant must complete and provide the results of the Solar

Glare Hazard Analysis Tool (SGHAT) for the Airport Traffic Control Tower cab and final approach paths, consistent with the Interim Policy, FAA Review of Solar Energy Projects on Federally Obligated Airports, or most recent version adopted by the FAA.”

IV. Amended Text: Section 7.01.D is hereby amended by adding the following to the list of special uses:

“54. Solar Gardens subject to the provisions of Section 4.00 of the Kendall County Zoning Ordinance.

55. Solar Farms subject to the provisions of Section 4.00 of the Kendall County Zoning Ordinance.”

V. Amended Text: Section 8.02.C is hereby amended by adding the following to the list of special uses:

“19. Solar Gardens subject to the provisions of Section 4.00 of the Kendall County Zoning Ordinance.”

VI. Amended Text: Section 8.03.H.1 is hereby amended by adding the following to the list of special uses:

“p. Solar Gardens subject to the provisions of Section 4.00 of the Kendall County Zoning Ordinance.”

VII. Amended Text: Section 8.09.B is hereby amended by adding the following to the list of special uses:

“9. Solar Gardens subject to the provisions of Section 4.00 of the Kendall County Zoning Ordinance.”

VIII. Amended Text: Section 9.02.C is hereby amended by adding the following to the list of special uses:

“15. Solar Gardens subject to the provisions of Section 4.00 of the Kendall County Zoning Ordinance.”

IX. Amended Text: Section 9.03.C is hereby amended by adding the following to the list of special uses:

“26. Solar Gardens subject to the provisions of Section 4.00 of the Kendall County Zoning Ordinance.”

X. Amended Text: Section 9.04.C is hereby amended by adding the following to the list of special uses:

“29. Solar Gardens subject to the provisions of Section 4.00 of the Kendall County Zoning Ordinance.”

XI. Amended Text: Section 9.05.C is hereby amended by adding the following to the list of special uses:

“20. Solar Gardens subject to the provisions of Section 4.00 of the Kendall County Zoning Ordinance.”

XII. Amended Text: Section 9.06.F is hereby amended by adding the following to the list of special uses:

“Solar Gardens. Solar gardens shall be a special use in the B-5 Business Planned Development District.”

XIII. Amended Text: Section 9.07.C is hereby amended by adding the following to the list of special uses:

“19. Solar Gardens subject to the provisions of Section 4.00 of the Kendall County Zoning Ordinance.”

XIV. Amended Text: Section 10.03.B is hereby amended by adding the following to the list of special uses:

“5. Solar Gardens subject to the provisions of Section 4.00 of the Kendall County Zoning Ordinance.”

XV. The Table of Uses is hereby amended to reflect Solar Gardens as special use in every zoning district and Solar Farms as a special use in the A-1 District.

IN WITNESS OF, this ordinance has been enacted by a majority vote of the Kendall County Board and is effective this 18th day of September, 2018.

Attest:

Kendall County Clerk
Debbie Gillette

Kendall County Board Chairman
Scott R. Gryder