

KENDALL COUNTY
ANIMAL CONTROL

**Kendall County Office Building; County Board room 210;
111 W. Fox Street; Yorkville IL**

Wednesday, April 26, 2017 – 8:30a.m.
A G E N D A

- 1. Call to Order**
- 2. Roll Call:** Lynn Cullick (Vice Chair), Matt Kellogg, Matthew Prochaska, John Purcell, Elizabeth Flowers (Chair)
- 3. Approval of Agenda**
- 4. Approval of Revised Minutes from February 22, and March 29, 2017 Minutes**
- 5. Monthly Reports**
 - Census Log
 - Bite Report
 - Operations Report
 - Job Posted for Part-Time Office Assistant
 - Update on Feral Cat spay/Neuter Program
 - Update on Open House Event scheduled for April 29th
 - Accounting Report
- 6. Old Business**
 - *Final Approval for Fence Construction behind Trailer (South side)*
- 7. New Business**
- 8. Public Comment**
- 9. Executive Session**
- 10. Action Items for County Board**
- 11. Adjournment**

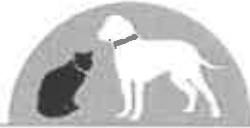

**KENDALL COUNTY
ANIMAL CONTROL**

**Wednesday, February 22, 2017 at 8:30AM
County Office Building
County Board Rooms 209-210
111 W. Fox Street; Yorkville IL**

MEETING MINUTES REVISED

Call to Order – The meeting was called to order by Committee Chair Elizabeth Flowers at 8:32a.m.

Roll Call

Committee Members Present: Elizabeth Flowers (Chair), Lynn Cullick (Vice Chair), Matthew Prochaska, Matt Kellogg. **With four members present, a quorum was established to conduct committee business.** John Purcell was (8:35am arrival)

Others present: Animal Control Director Laura Pawson, Dr. Gary Schlapp, County Administrator Jeff Wilkins

Approval of Agenda – Motion made by Member Cullick to approve the agenda, second by Member Kellogg. **With all in agreement, the motion carried.**

Approval of Minutes – Member Prochaska made a motion to approve the November 16, 2016 meeting minutes, second by Member Cullick. **With all in agreement, the motion carried.**

Monthly Report – Laura Pawson reviewed the census and bite/ethanasia reports with the committee.

<u>DOGS</u>	<u>JANUARY</u>	<u>YEAR TO DATE</u>
Intakes:	26	34
Adopted:	9	13
Reclaimed:	11	14
Transferred:	3	6
Euthanized:	2	2

Total Dogs Available for Adoption: 4
Total Unavailable Dogs: 4

<u>CATS</u>	<u>JANUARY</u>	<u>YEAR TO DATE</u>
Intakes:	9	11
Adopted:	3	8
Reclaimed:	0	0
Transferred:	2	2
Euthanized:	0	0

Total Cats Available for Adoption: 2
Total Unavailable Cats: 1

Bite Report

January/Total: 6 Dogs 1 Cat

Visitors January: 97

Events/News

- February 11- 14 Meet Your Match Event results: 2 dogs/ 3 cats adopted
- Volunteer Orientation was held on Thursday, February 16 from 6:30pm-8pm
- Luna to be featured as Record Newspaper Pet of the Week.

Operations Report – Laura Pawson reported she is training two new staff. She would like to get quotes to install a fenced-area behind the trailer to create an area for pet introductions and play. Volunteers expressed support for the idea. Funds raised in 2014, 2015 and 2016 from the “Pictures in the Park” volunteer fundraiser would pay for the project.

The Committee and staff had a general discussion about use for walkie-talkies and a third line for the cell phones.

Laura Pawson reported she is gathering data for repetitive complaints of dogs running at large causing property damage and attacking other pets. Often times the dogs return home before impoundment. In such cases, no fines or fees are assessed causing frustration for owners of the injured pet or damaged property.

Accounting Report – Jeff Wilkins provided an overview of the annual financial report with the committee. Through January revenues exceeded expenditures by \$4,847.

Old Business – Approve 2017 Regular Meeting Schedule
Member Prochaska made motion to set the 4th Wednesday of each month at 8:30am as the regular meeting time for the Animal Control Committee, second by Member Purcell. Motion passed unanimously with 5 affirmative votes. The County Board will consider the item for action on March 7.

Executive Session – None

Action Items for the County Board - Approve 4th Wednesday of each month at 8:30am as the regular meeting time for the Animal Control Committee

Public Comment – None

Adjournment – Member Prochaska made a motion to adjourn the meeting, second to the motion by Member Purcell. **With all in agreement, the meeting was adjourned at 9:15am.**

Respectfully Submitted,

Jeff Wilkins
County Administrator



KENDALL COUNTY
ANIMAL CONTROL

Wednesday, March 29, 2017 at 8:30AM
Historic Courthouse, East Wing Conference Room
109 W. Ridge Street, Yorkville, IL

MEETING MINUTES

Call to Order – The meeting was called to order by Committee Chair Elizabeth Flowers at 8:34a.m.

Roll Call

Committee Members Present: Matthew Prochaska, Elizabeth Flowers, John Purcell. **With three members present, a quorum was established to conduct committee business.**

Committee Members Absent: Lynn Cullick, Matt Kellogg

Others present: Laura Pawson, Jeff Wilkins

Approval of Agenda – Motion made by Member Prochaska to approve the agenda, second by Member Purcell. **With all in agreement, the motion carried.**

Approval of Minutes – Member Prochaska made a motion to approve the February 22, 2017 meeting minutes with revisions, second by Member Purcell. **With all in agreement, the motion carried.** Jeff Wilkins will correct the minutes and provide for the April 26, 2017 meeting for approval.

Monthly Report – Laura Pawson reviewed the census report with the committee.

Bite Report

20 Bites Total: 17 dogs, 3 cats

Visitors February: 113

Events/News

Saturday, April 8 – Adoption Event Pet Supplies Plus in Yorkville

Thursday, April 20 – Volunteer Orientation

Weekly Posting of “Pet of the Week” ad in Shaw Media Newspapers

Operations Report

- ***Discussion on Installing Dog Run behind Trailer (South side)*** – Ms. Pawson reported that she has discussed the construction of a new dog run on the south side of

the trailer with Mr. Smiley in Facilities Management. Ms. Pawson reported that work would be done by using donations that have been collected for three years through the Pictures in the Park fundraiser, the Popcorn Sales fundraiser and the Chastin Pawson Memorial Artwork Sale fundraiser, which total \$4,977.72 combined.

- ***Discuss Dog Running at Large/Nuisance Dog Ordinance*** - Ms. Pawson reported there has been an increase in number of reported dogs running at large/nuisance complaints in the recent months. Ms. Pawson presented the Kendall County ordinance that is dated 1968, as well as the ordinances for DeKalb and LaSalle Counties. Discussion on the need to update the Kendall County ordinance. Ms. Pawson and Jeff Wilkins will provide a proposed ordinance at the April 26, 2017 meeting for review by the committee, prior to full Board approval in May.
- ***New Kennel Manager/Animal Control Officer*** – Ms. Pawson reported that employee Bridget Galazkiewicz has been hired to serve in this capacity.
- ***Discussion on Open House Event*** – Ms. Pawson stated that she is planning to hold an Open House adoption event in late April similar to the “Name Your Own Price” event held last year to encourage adoption of animals at the facility.

Accounting Report – Jeff Wilkins provided an overview of the financial report with the committee, and said that February was a good month for revenues over expenditures.

Old Business – Member Flowers asked that the dates for the meetings be corrected on the County calendar to reflect a meeting each month on the fourth Wednesday.

Executive Session – None

Action Items for the County Board - None

Public Comment – None

Adjournment – Member Purcell made a motion to adjourn the meeting, second to the motion by Member Prochaska. **With all in agreement, the meeting was adjourned at 9:37am.**

Respectfully Submitted,

Valarie McClain
Recording Clerk

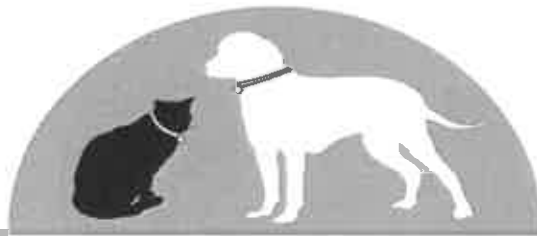

KENDALL COUNTY
ANIMAL CONTROL

Financial Statements FY17
March 2017

KENDALL COUNTY ANIMAL CONTROL
Statement of Revenues And Expenditures
3/31/2017

	CURRENT YEAR				PRIOR YEAR	VARIANCE
	FY17 Budget	March Actual	YTD Actual	YTD Percent of Budget	3/31/16 YTD	FY17 YTD v. FY16 YTD
Animal Control Fund #350						
Revenues						
Rabies Tags Sold	\$ 184,000	\$ 18,220	\$ 78,375	42.0%	\$ 68,179	10,196
Fines & Fees (Total)	25,000	3,613	10,592	42.4%	7,722	2,870
Donations	5,000	15	1,225	24.5%	2,116	(891)
Intact Registration Fee	12,000	1,805	4,230	35.3%	4,599	(369)
Miscellaneous	300		-		140	(140)
Total Revenues	\$ 226,300	\$ 23,653	\$ 94,422	41.7%	\$ 82,756	\$ 11,666
Expenditures						
Salary - Animal Control Warden	\$ 47,800	\$ 3,677	16,361	34.2%	\$ 9,923	\$ 6,438
Salary - Assistant Warden	29,120	971	6,781	23.3%	4,454	2,327
Salary - Other	61,908	4,062	17,449	28.2%	19,464	(2,015)
Salary - Administrator	6,500	500	2,242	34.5%	2,169	73
Supplies	2,000		509	25.4%	167	342
Postage	1,100	141	334	30.4%	324	10
Training	1,500	100	225	15.0%	250	(25)
Telephone & Pager	250		44	17.8%	42	2
Equipment	4,000	123	661	16.5%	26	635
Vehicle Expense & Gasoline	2,500	46	269	10.8%	327	(58)
Uniforms	500		-			
Volunteers/Public Relations	1,000		629	62.9%	599	30
Neuter/Spay Fees			-		106	(106)
Rabies Tags	2,500		-		1,701	(1,701)
Transportation, Board & Care	15,000	810	4,152	27.7%	2,023	2,129
Kennel Improvements			-		150	(150)
Observation/Disposal	500		-			
Microchips	1,700		-		1,738	(1,738)
Capital Expenditures	2,500		34	1.4%		34
Total Operating Expenditures	\$ 180,376	\$ 10,429	\$ 49,690	27.6%	\$ 43,463	\$ 6,227
Transfer to General Fund for Health Ins.	\$ 8,491	\$ 1,527	\$ 5,313	62.6%	\$ 2,818	\$ 2,495
Transfer to IMRF & SS Fund	25,890	1,621	7,581	29.3%	5,799	1,782
Transfer to Building Fund	10,000					
Total Transfers Out	\$ 44,381	\$ 3,148	\$ 12,894	29.1%	\$ 8,617	\$ 4,277
Total Expenditures & Transfers Out	\$ 224,757	\$ 13,577	\$ 62,585	27.9%	\$ 52,080	\$ 10,505
Total Revenues Over/(Under) Expenditures	\$ 1,543	\$ 10,076	\$ 31,837		\$ 30,676	\$ 1,161

**KENDALL COUNTY ANIMAL CONTROL FUND #350
FUND (CASH) BALANCE
FY 2017**

MONTH	FY17 Monthly REVENUE OVER/(UNDER) EXPENSES	FY17 FUND (CASH) BALANCE	FY16 Monthly REVENUE OVER/(UNDER) EXPENSES	FY16 FUND (CASH) BALANCE
Beginning Fund (Cash) Balance		\$ 128,837		\$ 112,935
December-16	\$ (2,667)	126,170	\$ (2,409)	110,526
January-17	7,513	133,683	25,397	135,923
February-17	16,915	150,597	4,876	140,799
March-17	10,076	160,673	2,813	143,611
April-17			9,724	153,335
May-17			5,475	158,810
June-17			6,406	165,216
July-17			3,596	168,812
August-17			9,143	177,955
September-17			7,081	185,036
October-17			2,861	187,896
November-17			(59,060)	128,837
Fund (Cash)	\$ 31,836		\$ 15,901	
YTD Fund Balance		\$ 160,673		\$ 128,837

KENDALL COUNTY ANIMAL CONTROL FUND #350
VOUCHERS PAID
March-2017

LINE ITEM	VENDOR	DESCRIPTION	AMOUNT	
3502-000-6201	POSTAGE			
	Postage	Jan 26 - Feb 28, 2017	80.13	
	Postage	Feb 28 - Mar 21, 2017	<u>60.72</u>	140.85
3502-000-6206	TRAINING			
	County Animal Controls of IL	Training Pawson	<u>100.00</u>	100.00
3502-000-6216	EQUIPMENT			
	Action Graphix Ltd.	Trailer Signs & Installation	<u>123.00</u>	123.00
3502-000-6217	VEHICLE EXPENSE & GASOLINE			
	Kendall County Highway	Fuel Purchase	<u>45.98</u>	45.98
3502-000-6897	TRANSPORTATION, BOARD & CARE			
	Countryside Veterinary Clinic	Board & Care	382.66	
	Jeffers, Inc.	Vaccinations	230.79	
	Shaw Media	Adoption Ads	5.00	
	VCA Aurora Animal Hospital	Board & Care	<u>270.36</u>	888.81
TOTAL			<u><u>\$ 1,298.64</u></u>	

KENDALL COUNTY ANIMAL CONTROL
Statement of Revenues And Expenditures
3/31/2017

Animal Control Capital Fund #340

	FY17 Budget	March Actual	YTD Actual	YTD Percent of Budget	Fund Balance
Beginning Balance	125,571		125,571		FY10 \$70,000 FY11 87,769 FY12 41,062 FY13 46,762 FY14 51,661 FY15 69,276 FY16 125,571 FY17 124,561
Revenue					
Other Revenue	-				
Total Revenue	-				
Expenditure					
Expense - Building Improvements	17,800	252	1,010	5.7%	
Total Expenditure	17,800	252	1,010	5.7%	
Transfers In					
Transfers In - from Animal Control Fund	10,000				
Total Transfers In	10,000	-	-		
Ending Balance	\$ 117,771	\$ (252)	\$ 124,561		

Animal Medical Care Fund #341

	FY17 Budget	March Actual	YTD Actual	YTD Percent of Budget	Fund Balance
Beginning Balance	32,810		32,810		FY13 \$250 FY14 21,935 FY15 33,497 FY16 32,810 FY17 33,363
Revenue					
Donations & Receipts	-	880	880		
Total Revenue	-	880	880		
Expenditure					
Animal Medical Care Expenses	3,000	-	327	10.9%	
Heartworm Testing	-				
FelLuk/FIV Testing	-				
Total Expenditure	3,000	-	327	10.9%	
Ending Balance	\$ 29,810	\$ 880	\$ 33,363		

KENDALL COUNTY ANIMAL CONTROL
Statement of Revenues And Expenditures
3/31/2017

State Pet Population Fund #860

	FY17 Budget	March Actual	YTD Actual	YTD Percent of Budget	Fund Balance
Beginning Balance	9,830		9,830		FY10 \$4,750 FY11 850 FY12 260
Revenue					FY13 4,020 FY14 5,865 FY15 7,990
Fees: Dogs Running at Large	1,500	140	400	26.7%	FY16 9,830
Total Revenue	1,500	140	400	26.7%	FY17 10,230
Expenditure					
Remittance to State of IL	9,490		-		
Total Expenditure	9,490	-	-		
Ending Balance	\$ 1,840	\$ 140	\$ 10,230		

Animal Population Control Fund #870

	FY17 Budget	March Actual	YTD Actual	YTD Percent of Budget	Fund Balance
Beginning Balance	97,935		97,935		FY10 \$29,314 FY11 46,246 FY12 60,939
Revenue					FY13 64,358 FY14 71,549 FY15 83,094
Fees	16,000	2,220	5,330	33.3%	FY16 97,935
Total Revenue	16,000	2,220	5,330	33.3%	FY17 100,901
Expenditure					
Spay/Neuter Adopted Dogs/Cats	4,500	430	1,970	43.8%	
Spay/Neuter Targeted Dogs/Cats	2,500	110	395	15.8%	
Total Expenditure	7,000	540	2,365	33.8%	
Ending Balance	\$ 106,935	\$ 1,680	\$ 100,901		



**KENDALL COUNTY
ANIMAL CONTROL**

**April 26, 2017
Kendall County Animal Control**

March Visitors AM: 20

March Visitors PM: 21

Total: 41

March 2017 Dog

Dog Intakes: 26

Dogs Adopted: 2

Reclaimed: 17

Transferred: 0

Euthanized: 1 (3/9/17 "Arrow" Pit Bull Terrier, Reason: Behavior)

March 2017 Cat

Cat Intakes: 4

Cats Adopted: 2

Cats Reclaimed: 1

Transferred: 0

Euthanized: 0

April 2017- Month to Date/Year to Date/2016 Comparison YTD

Dog Intakes to Date: 20/87/75

Dogs Adopted: 0/21/10

Reclaimed: 13/50/48

Transferred to Rescue: 2/12/7

Euthanized: 2/5/2

Total Available Dogs for Adoption: 9/7

Total Unavailable Dogs: 2/7

Cat Intakes to date: 4/20/12

Cats Adopted: 0/13/11

Cats Reclaimed: 1/1/2

Transferred to Rescue: 0/4/1

Euthanized: 0/1/2

Total Adoptable Cats: 3/0

Total Unavailable Cats: 3 (1 cat/2 kittens) /3

EVENTS AND MEDIA:

Upcoming: Saturday, April 29, 2017 "Open House" Event 10am-2pm

Upcoming: Pet of the Week, Record Newspaper "Dusty" Cattle Dog Mix

Upcoming: Saturday, May 13, 2017 Pet Supplies Plus Adoption Event 11am-2pm

Upcoming: Volunteer Orientation, May 9, 2017 6:30-8:00pm



KENDALL COUNTY
ANIMAL CONTROL

MARCH 2017

ANIMAL BITES TO HUMANS REPORTED TO KCAC

DATE	OWNER	BITING ANIMAL	PERSON BITTEN
3/1/17	OWNER	"ZENA" LABRADOR FEMALE (ALTERED/UTD)	OWNER
3/4/17	OWNER	"PATCH" PIT BULL MIX (NOT UTD/INTACT)	OWNER
3/4/17	OWNER	"BRIGGS" (ALTERED/UTD) PUG/SHAR PEI X	OTHER
3/4/17	OWNER	"KANE" PIT BULL MIX (NOT UTD/ALTERED)	OTHER
3/4/17	OWNER	"LUCY" GER. SHEP/HUSKY MIX (ALTERED/NOT UTD)	OTHER
3/5/17	OWNER	"BISCUIT" JACK RUSSELL TER (ALTERED/UTD)	OTHER
3/6/17	OWNER	"SKELETOR" PIT BULL (NOT UTD/INTACT)	OWNER
3/6/17	OWNER	"THOR" GERMAN SHEPHERD (INTACT/UTD)	OTHER
3/6/17	UNKNOWN	GREY PIT BULL (UNK/UNK)	OTHER
3/6/17	OWNER	"CHICA" GERMAN SHEPHERD (UTD/ALTERED)	OWNER
3/8/17	OWNER	"DAISEY" BORDER COLLIE (ALTERED/UTD)	OTHER
3/8/17	OWNER	"BAILEY" TERRIER MIX (ALTERED/UTD)	OWNER
3/12/17	OWNER	"MARLEY" LABRADOR (ALTERED/UTD)	OTHER
3/13/17	OWNER	"CHARLIE" DACHSHUND (ALTERED/NOT UTD)	OWNER
3/14/17	OWNER	"SKYE" PIT BULL (ALTERED/NOT UTD)	OWNER
3/15/17	OWNER	"ROY" SHIBA INU (ALTERED/UTD)	OWNER
3/18/17	OWNER	"SASSAFRAS" PIT BULL MIX (ALTERED/UTD)	OTHER
3/22/17	OWNER	"ENZIO" TERRIER MIX (UTD/INTACT)	OWNER
3/24/17	OWNER	"CAPONE" PIT BULL (UTD/ALTERED)	OTHER
3/27/17	OWNER	"NALA" PIT BULL (UTD/ALTERED)	OTHER

3/27/17 OWNER
3/28/17 OWNER
3/29/17 OWNER

"GRACIE" SHELTYE (ALTERED/UTD)
"HARLEY" GER. SHEP (UTD/ALTERED)
"METRO"GER. SHEP (NOT UTD/INTACT)

OTHER
OTHER
OTHER

Labrador Retriever	2
Pit Bull Terrier Mix	3
Pug/ Shar Pei Mix	1
German Shepherd/Husky Mix	1
German Shepherd Mix	1
Jack Russell Terrier Mix	1
German Shepherd	3
Terrier Mix	1
Dachshund	1
Border Collie	1
Pit Bull Terrier	5
Shiba Inu	1
Shetland Sheepdog	2

Total: 23

Multiple Bites: 1



KENDALL COUNTY
ANIMAL CONTROL



Open House Event

Saturday, April 29th 2017

From: 10am-2pm

**802 West John Street
Yorkville, IL**

Meet the Adoptable Pets



Popcorn and Balloons



Kid's Facepainting by "Glitter ~n~ Disguise"

Refreshments



JILCS 5/ Animal Control Act.

injury or death of any individual dog that has been found to be a "dangerous dog" upon 3 separate occasions.
(Source: P.A. 93-548, eff. 8-19-03.)

(510 ILCS 5/3) (from Ch. 8, par. 353)

Sec. 3. The County Board Chairman with the consent of the County Board shall appoint an Administrator. Appointments shall be made as necessary to keep this position filled at all times. The Administrator may appoint as many Deputy Administrators and Animal Control Wardens to aid him or her as authorized by the Board. The compensation for the Administrator, Deputy Administrators, and Animal Control Wardens shall be fixed by the Board. The Administrator may be removed from office by the County Board Chairman, with the consent of the County Board.

The Board shall provide necessary personnel, training, equipment, supplies, and facilities, and shall operate pounds or contract for their operation as necessary to effectuate the program. The Board may enter into contracts or agreements with persons to assist in the operation of the program and may establish a county animal population control program.

The Board shall be empowered to utilize monies from their General Corporate Fund to effectuate the intent of this Act.

The Board is authorized by ordinance to require the registration and may require microchipping of dogs and cats. The Board shall impose an individual dog or cat registration fee with a minimum differential of \$10 for intact dogs or cats. Ten dollars of the differential shall be placed either in a county animal population control fund or in the State's Pet Population Control Fund. If the money is placed in the county animal population control fund it shall be used to (i) spay, neuter, or sterilize adopted dogs or cats or (ii) spay or neuter dogs or cats owned by low income county residents who are eligible for the Food Stamp Program. All persons selling dogs or cats or keeping registries of dogs or cats shall cooperate and provide information to the Administrator as required by Board ordinance, including sales, number of litters, and ownership of dogs and cats. If microchips are required, the microchip number may serve as the county animal control registration number.

In obtaining information required to implement this Act, the Department shall have power to subpoena and bring before it any person in this State and to take testimony either orally or by deposition, or both, with the same fees and mileage and in the same manner as prescribed by law for civil cases in courts of this State.

The Director shall have power to administer oaths to witnesses at any hearing which the Department is authorized by law to conduct, and any other oaths required or authorized in any Act administered by the Department.

This Section does not apply to feral cats.

(Source: P.A. 93-548, eff. 8-19-03; 94-639, eff. 8-22-05.)

(510 ILCS 5/4) (from Ch. 8, par. 354)

Sec. 4.

When the Boards of 2 or more counties, through mutual agreement, wish to join to effectuate any part or all of this Act, they shall make written request to the Director, setting forth the geographical area and the Sections of this Act involved. Whenever, as ascertained from investigation, hearing, or otherwise, the Director determines it is advisable that these counties form a District, he may designate and establish such District. A District Board shall be formed and shall effectuate this Act as set forth for an individual county.

(Source: P.A. 78-795.)

TAG
FEES



administration of serum or vaccine, minor medical care, and for paying the cost of stray dog control, impoundment, education on animal control and rabies, and other costs incurred in carrying out the provisions and enforcement of this Act or any county or municipal ordinance relating to animal control, or animal-related public health or public nuisances, except as set forth in Section 19 of this Act. (Source: P.A. 98-217, eff. 8-9-13.)

(510 ILCS 5/7.1) (from Ch. 8, par. 357.1)
Sec. 7.1. In addition to any other fees provided for under this Act, any county may charge a reasonable fee for the pickup and disposal of dead animals from private for-profit animal hospitals. This fee shall be sufficient to cover the costs of pickup and delivery and shall be deposited in the county's animal control fund. (Source: P.A. 93-548, eff. 8-19-03.)

(510 ILCS 5/8) (from Ch. 8, par. 358)
Sec. 8. Rabies inoculation. Every owner of a dog 4 months or more of age shall have each dog inoculated against rabies by a licensed veterinarian. Every dog shall have a second rabies vaccination within one year of the first. Terms of subsequent vaccine administration and duration of immunity must be in compliance with USDA licenses of vaccines used. A veterinarian immunizing a dog, cat, or ferret against rabies shall provide the Administrator of the county in which the dog, cat, or ferret resides with a certificate of immunization. Evidence of such rabies inoculation shall be entered on a certificate the form of which shall be approved by the Board and which shall contain the microchip number of the dog, cat, or ferret if it has one and which shall be signed by the licensed veterinarian administering the vaccine. Only one dog, cat, or ferret shall be included on each certificate. Veterinarians who inoculate a dog shall procure from the County Animal Control in the county where their office is located serially numbered tags, one to be issued with each inoculation certificate. The Board shall cause a rabies inoculation tag to be issued, at a fee established by the Board for each dog inoculated against rabies.

Rabies vaccine for use on animals shall be sold or distributed only to and used only by licensed veterinarians. Such rabies vaccine shall be licensed by the United States Department of Agriculture.

If a licensed veterinarian determines in writing that a rabies inoculation would compromise an animal's health, then the animal shall be exempt from the rabies inoculation requirement, however, the owner is still responsible for the tag fees.

If a bite occurs from an exempt animal, the exempt animal shall be treated as an unvaccinated animal. If the animal is exempt, the animal shall be re-examined by a licensed veterinarian on no less than an annual basis and be vaccinated against rabies as soon as the animal's health permits. (Source: P.A. 99-658, eff. 7-28-16.)

(510 ILCS 5/9) (from Ch. 8, par. 359)
Sec. 9. Any dog found running at large contrary to provisions of this Act may be apprehended and impounded. For this purpose, the Administrator shall utilize any existing or available animal control facility or licensed animal shelter. The dog's owner shall pay a \$25 public safety fine, \$20 of which shall be deposited into the Pet Population Control Fund and \$5 of which shall be retained by the county or municipality. A dog found running at large contrary to the provisions of this Act a second or subsequent time must be

1855 W Earhart Dr.
Sandwich, IL 60548
630-966-0209 Office
815-786-2070 Office
815-786-2078 Fax



Operations
41W 350 Jericho Road
Aurora, IL 60506
Licensed - Bonded - Insured
Quality Service Since 1998

Name: Kendall County Animal Shelter c/o Laura
Billing Address: 802 W John St
City: Yorkville Twp _____ State: IL Zip Code _____
County: Kendall Subdivision _____
E-mail: lpawesch@co.kendall.il.us

Date: March 15, 2017
Home Phone: 630-553-9256 Work
Cell Phone: _____
Fax: _____

Job Description		Wood Fence		Chain Link Fence		Aluminum	PVC Fence	
Total Linear Feet 93'	Height 8'	Height	Boards	Height 8'	Galvanized yes	Height	Height	Picket Picket Spacing
Walk Gates 2-4'	Trimming	Style	<input type="checkbox"/> Arch <input type="checkbox"/> Scallop <input type="checkbox"/> Flat	Vinyl Color	Gauge 9	Style	Color	Tongue & Groove
Drive Gates	JULIE Locate Ideal Fence	Posts	Western Red Cedar	Terminal Posts 3"SS40	Gate Posts 3"SS40	Color	Style	Top Rail
Tail-4 Dev'n	Permit Customer	Post Tops	Pressure Treated Pine	Line Posts 2 1/2"SS40	Top Rail 1 5/8"SS40	Posts	Posts	Mid Rail
End Away	Follow Grade yes	2nd Rails <input type="checkbox"/> 2 <input type="checkbox"/> 3	Other	Tension wire Braiding n/a	Other bottom rail	Rails Rails per section	Post Tops	Bottom Rail
Dirt Spills spread	<input type="checkbox"/> Core Drills <input type="checkbox"/> Concrete Cuts <input type="checkbox"/> Asphalt Breaks	Warranty Labor: 5 years		Warranty Labor: 2 years		Picket Spacing	Warranty Labor: 5 years	
Concrete Footings wet	Other	Material: One year Gates: 6 months <small>*Does not include wrapping, checking or cupping of wood*</small>		Material: Per Manufacturer Gates: 6 months		Material: Limited Lifetime per Manufacturer	Material: Limited Lifetime per Manufacturer Gates: 6 months	

J.L. description: **F&I 93' of 8' galvanized chain link fence. 3"SS40 terminal & gate posts, 2 1/2"SS40 line posts. Posts set in wet concrete footings +36" deep. (2) 4' walk gates, gates welded frame construction. 1 5/8"SS40 top & bottom rail. Prevailing wages applied.**

Price \$4,800.00
Down Payment 50%
Balance Due
Terms of sale Balance Due upon Completion

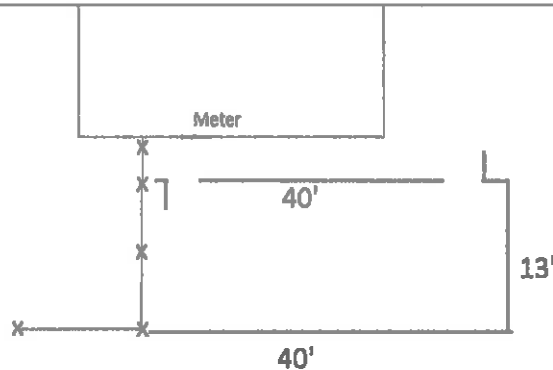

- Customer agrees to do the following:**
- *Obtain permit, HOA Rules and approval, Covenants & final Inspections.
 - *Provide most current and accurate plat of survey. Ideal Fence can only be responsible for location of property lines with accurate survey.
 - *Removal of objects, landscaping in the fence line.
 - *Pay in full upon completion.
 - *If balance is not paid in full with 14 days of completion a monthly interest charge of 3% will be applied to the balance.
 - *Ideal Fence may use on its own discretion any legal remedy available to collect unpaid and overdue balance. Customer agrees to pay all attorney fees, collection and court costs on past due outstanding balances.
 - *Customer execution of this contract gives Ideal Fence, Inc. permission to repossess any or all of the unpaid materials used for the customer.
 - **JULIE Locate includes all publically installed utility lines. Ideal Fence is not responsible for sprinkler systems, invisible fences, private plumbing or electric as well as parking lot lights.

Customer Initial Here
Proposal Expires April 15, 2017

Kevin Turner

Customer Signature

Ideal Fence



Residential & Commercial



"Over 20 Years of Experience"



"Financing Available"

www.classicfenceinc.net

classicfencemail@yahoo.com



Name Kendall County Animal Shelter Date 3-10-17
 Billing address _____ Contact Laura
 City _____ Typ State _____ Zip code _____ Home phone _____
 County _____ Subdivision _____ Work phone 630 553-9256
 Job site _____ Cell phone _____
 Directions _____ Fax _____
 Cross street _____ Referred by _____ E-mail L.P.A. WASH @ Kendall IL us

Job description Furnish/install about 93 of 8' high galvanize chain link w/ 2 4 wide single gates Top + Bottom mil 9 gauge wire

Total linear feet notes included: <u>93'</u>	Line post: <u>2 1/2"</u>	Terminal post: <u>3"</u>	Gate post: <u>3 1/2"</u>	Existing fence: <input type="checkbox"/> Take down <input type="checkbox"/> Keep wood <input checked="" type="checkbox"/> N/A	Type: <input type="checkbox"/> Flat wood <input checked="" type="checkbox"/> N/A	Underground Utilities (MUE): <input type="checkbox"/> Customer <input checked="" type="checkbox"/> Classic Fence
Height: <u>8'</u>	Style: <u>Chain link</u>	Face nail: <input type="checkbox"/>	Top nail: <input type="checkbox"/>	INSTALL: <input type="checkbox"/> Concrete <input type="checkbox"/> Asphalt	Dim Inhibit: <input type="checkbox"/> Customer <input type="checkbox"/> Classic Fence	City's Permit: <input checked="" type="checkbox"/> Customer <input type="checkbox"/> Classic Fence
Board size: <u>1 5/8"</u>	Rolls: <input type="checkbox"/>	Follow Grade: <input checked="" type="checkbox"/>	Level on Top: <input type="checkbox"/>	<input type="checkbox"/> Flange <input type="checkbox"/> Core drill	IN Alternate Prices - Initial any agreed to:	
Color: <u>Galvanize</u>	Nails: <input type="checkbox"/>	Wet concrete: <input checked="" type="checkbox"/> Yes <input type="checkbox"/> No	Paint: <input type="checkbox"/> Yes <input type="checkbox"/> No	Seep lines: <input type="checkbox"/> Yes <input type="checkbox"/> No		
Post Removal: <input checked="" type="checkbox"/> Yes <input type="checkbox"/> Leave in piles <input type="checkbox"/> Spread	PREFIN: <input type="checkbox"/> Galvanize <input type="checkbox"/> White: <input type="checkbox"/> Trim: <input type="checkbox"/> Welded					
<u>Prevailing Wages</u>						
Price: <u>5140⁰⁰</u>	Down Payment: <u>50% + PO</u>	Balance:	Terms of Sale: <u>C.O.D</u>			

Classic Fence is not responsible for sprinkler systems, in-slab fences and any lines not marked by Julie. No oral agreements of any kind between Customer and Classic Fence Inc. or its agents and representatives will be considered valid. I hereby accept the terms and conditions on both sides of this contract.

Customer Signature _____ Date of acceptance _____ Francisco Respectfully submitted by:



KENDALL COUNTY FENCE

Proposal - Order

_____ WEEKS - WEATHER PERMITTING

(630) 554-2673

INFO@KENDALLCOUNTYFENCE.COM

9124 BYPASS 30

BRISTOL, IL, 60512

DATE Feb 27, 17

BUYER: Kendall County Animal Shelter JOB SITE: _____
Prevailing Wages

L PAWSON & CO, KENDALL, IL, US

Sauwan

Phone: 553-9256

QUANTITIES & SPECIFICATIONS

Quantity	
93'	of 8' High Galvanized Chain Link Fencing with top & Bottom Rail
2	4' Wide Gates

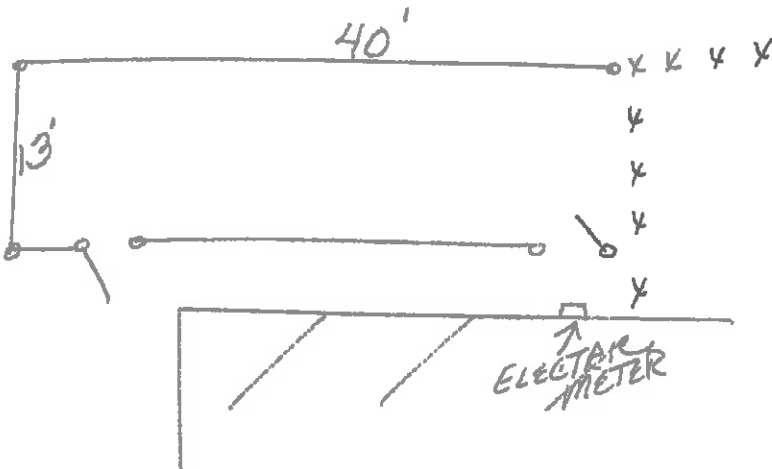

TOTAL PRICE: \$16,000.⁰⁰

Deposit: _____

Balance: _____

No of Feet	COLOR	BOARDS	SURVEY PLAT	PERMIT
93'				
HEIGHT 8'	TERMINALS 3"	RAILS	TRIM BUSHES No	CALL UTILITIES We call
Gauge 9	LINE POSTS 2 1/2"	POSTS	TAKE DOWN No	CONCRETE SET Yes
GATES 2	TOP RAIL + BOTTOM RAIL 1 5/8"	PANELS	HAUL AWAY No	GRAVEL SET

TERMS: **50% DOWN PAYMENT—BALANCE DUE UPON COMPLETION** Prices good for _____

Fencing is to follow normal ground contour unless otherwise written on this contract.
 Buyer is to establish and be responsible for property lines and will remove all obstructions that interfere with installation.
 If buyer requests temporary stoppage of work after construction has been started necessitating additional trips by erecting crew, Buyer agrees to pay extra expenses involved.
 Buyer assumes the responsibility of dirt removal unless it is marked on this contract.
 Buyer is responsible for securing and payment for county, city or village permits and following the ordinances. Buyer is also responsible for obtaining an approval letter (where applicable) from their homeowners association and complying with their codes and covenances. Buyer also agrees that KENDALL COUNTY FENCE will not be held responsible or liable for any damage of any underground obstructions.

METAL FENCING GUARANTEED 5 YEAR

WOOD FENCING GUARANTEED _____ YEAR

Company Representative _____

Buyer _____

Accepted and approved this, _____ day of _____, 20_____

By _____