

**KENDALL COUNTY FOREST PRESERVE DISTRICT
FINANCE COMMITTEE MEETING
AGENDA**

THURSDAY, MAY 26, 2022

4:00 P.M.

KENDALL COUNTY OFFICE BUILDING – ROOMS 209 AND 210, YORKVILLE IL 60560

- I. Call to Order
- II. Roll Call
- III. Approval of Agenda
- IV. Public Comments
- V. Motion to Forward Claims to Commission for Approval
- VI. Review of Financial Statements through April 30, 2022
- VII. Pickerill-Pigott Estate House Construction Project Management
 - a. Pre-Construction Phase Activities Progress Report
 - b. Discussion of Donating Contractor Outreach and Pre- Construction Phase Activities
 - c. Pre-Construction Phase Supply and Equipment Purchases
- VIII. Grounds Maintenance Staff – Proposed Market Salary Increase
- IX. Maramech Entry Gate Replacement Proposal and IPMG Insurance Payment
- X. District Equipment Auction Recommendations
- XI. Other Items of Business
 - a. Groot Inc. Overpayment Credit
 - b. T-Mobile Wireless Services Transition Progress (Phones and Wireless Internet)
 - c. Rt. 71 Trail – Intergovernmental Agreement; IDOT Letter of Agreement – Timeframes for Approval
 - d. Little Rock Creek Dam Removal – Res, Inc. – Kendall County Fox River Watershed Escrow Account
- XII. Public Comments
- XIII. Executive Session
- XIV. Adjournment

Kendall County Office Building - Rooms 209 and 210 - 111 W. Fox Street - Yorkville, Illinois 60560
If special accommodations or arrangements are needed to attend this District meeting, please contact the
Administration Office at 630-553-4025 a minimum of 24-hours prior to the meeting time.

Claims Listing

5/26/2022 12:46:54 PM

Department	Vendor #	Vendor Name	Invoice #	Invoice Description	GL Account	Description	Invoice Amount
Ellis Barn	1323	MENARDS	42145	Carabiner, screw-Ellis Barn	19001161 68580	Grounds and Maintenance	\$22.68
						Sub-Total	\$22.68
					Ellis Barn	Total	\$22.68
Ellis House	124	BARRETT'S ECOWATER	0010381053122	Ellis Water service, glass jugs	19001160 62270	Utilities	\$521.20
	2047	COMED	9361548011053122	ComEd Ellis House	19001160 62270	Utilities	\$141.90
						Sub-Total	\$663.10
Ellis Riding Lessons	1091	K & K WELL DRILLING	32113	4 containers of hydrogen peroxide-5 gallon-Ellis	19001160 68580	Grounds and Maintenance	\$148.00
						Sub-Total	\$148.00
					Ellis House	Total	\$811.10
Ellis Sunrise Center	2057	MATTHEW CAVINESS	12022038	Trim and shoes for horses-Ellis	19001164 63020	Vet & Farrier	\$350.00
						Sub-Total	\$350.00
					Ellis Riding Lessons	Total	\$350.00
Ellis Sunrise Center	51	SYNCB/AMAZON	1YRG-1D9N-W1TG	Fly tarp, fly masks-Ellis Animal Care	19001167 63000	Animal Care & Supplies	\$265.44
						Sub-Total	\$265.44
					Ellis Sunrise Center	Total	\$265.44

Environmental Educ. Natr'l Beg.	51	SYNCB/AMAZON	1F67-QQ4L- JGCM	Dinsoaur themed supplies for NB end of year	19001178 63030	Program Supplies	\$75.21
						Sub-Total	\$75.21
					Environmental Educ. Natr'l Beg.	Total	\$75.21
Environmental Education Camps	51	SYNCB/AMAZON	1MLN-J7N4- Q3F3	Curious George Book for Summer Camp	19001177 63030	Program Supplies	\$4.75
	51	SYNCB/AMAZON	1YRG-1D9N- LC74	Camp supplies	19001177 63030	Program Supplies	\$564.23
						Sub-Total	\$568.98
Environmental Education School	3630	JUSTINE SKILLMAN	RecPro #7240	Refund for Nature Warriors Camp	19001177 63040	Security Deposit Refund	\$185.00
						Sub-Total	\$185.00
					Environmental Education Camps	Total	\$753.98
Environmental Education School	51	SYNCB/AMAZON	11LK-TXCR- Q3GF	School Programs-White School Glue	19001176 63030	Program Supplies	\$18.74
						Sub-Total	\$18.74
					Environmental Education School	Total	\$18.74
Forest Preserve Director	51	SYNCB/AMAZON	14Q7-LXG9-J1HL	Pollinator Fest Supplies	190011 62000	Office Supplies	\$137.57

**Forest Preserve
Director**

51	SYNCB/AMAZON	1Y66-MLGV- QV3Y	Amazon-Beverage Dispenser	190011 62000	Office Supplies	\$20.75
1020	ILLINOIS STATE POLICE SERVICES FUND	05718	Background Checks	190011 62000	Office Supplies	\$40.00
					Sub-Total	\$198.32
67	AMEREN ILLINOIS	27864440060531 22	Ameren-Millbrook S	190011 63510	Electric	\$39.75
					Sub-Total	\$39.75
1152	KENDALL PLUMBING & HEATING	99300499268	CPVC Repair at Hoover	190711 66500	Miscellaneous Expense	\$1,250.00
					Sub-Total	\$1,250.00
695	GROUND EFFECTS INC	468379-000	Road Gravel for Hoover Garden	190011 68500	Project Fund Expenses	\$142.40
695	GROUND EFFECTS INC	468388-000	Gravel for Hoover Garden	190011 68500	Project Fund Expenses	\$142.40
695	GROUND EFFECTS INC	468399-000	Mulch for Hoover Garden	190011 68500	Project Fund Expenses	\$106.04
695	GROUND EFFECTS INC	468416-000	Mulch for Hoover Garden	190011 68500	Project Fund Expenses	\$159.06
695	GROUND EFFECTS INC	468426	Mulch for Hoover Garden	190011 68500	Project Fund Expenses	\$159.06
695	GROUND EFFECTS INC	468436-000	Mulch for Hoover Garden	190011 68500	Project Fund Expenses	\$79.53
1323	MENARDS	42599	Menards Grounds Supplies, Hoover Garden Supplies	190011 68500	Project Fund Expenses	\$64.55
1323	MENARDS	43014	MEwards-Wood for Hoover Garden planters	190011 68500	Project Fund Expenses	\$133.46
1323	MENARDS	43101	Menards-Hoover Garden Supplies	190011 68500	Project Fund Expenses	\$55.29
1883	WATER PRODUCTS- AURORA	0309257	Equipment/supplies for Hobbit Tunnel repairs	190011 68500	Project Fund Expenses	\$148.40

Forest Preserve Director				Sub-Total	\$1,190.19
1153	KENDALL CO HIGHWAY DEPT	Welcome Signs	Welcome Signs	191411 68530	Preserve Improvements \$300.00
					Sub-Total \$300.00
158	BLOOD HOUND	00196502	Pickerill Line locating	191311 70330	Construction \$822.50
					Sub-Total \$822.50
				Forest Preserve Director Total	\$3,800.76
51	SYNCB/AMAZON	17DH-LGXF-RFPW	Truck uplifters, insulated medical case for epipen	19001183 62160	Equipment \$24.99
107	AUTOMOTIVE SPECIALTIES INC	25334	Drain valve, hub seals-2009 Ford F250	19001183 62160	Equipment \$835.90
413	DEKANE EQUIPMENT CORP	023674	Cub Cadet Tractor Purchase	19001183 62160	Equipment \$3,199.00
					Sub-Total \$4,059.89
51	SYNCB/AMAZON	1NMR-DFCT-FN6P	Education Dept Uniforms	19001183 62400	Uniforms / Clothing \$111.40
					Sub-Total \$111.40
1452	NICOR	85662610121053122	Nicor Millbrook S	19001183 63090	Natural Gas \$161.20
1452	NICOR	87946110001053122	Nicor Harris	19001183 63090	Natural Gas \$234.10
					Sub-Total \$395.30

Grounds and Natural Resources												
51	SYNCB/AMAZON	17DH-LGXF-RFPW			Truck uplifters, insulated medical case for epipen	19001183	63110		Shop Supplies			\$21.99
1323	MENARDS	42599			Menards Grounds Supplies, Hoover Garden Supplies	19001183	63110		Shop Supplies			\$83.89
									Sub-Total			\$105.88
									Grounds and Natural Resources			\$4,672.47
3631	MARCELA PEREA	22-00141			Sec Dep Return-Moonseed	19001171	63040		Security Deposit Refund			\$100.00
3633	KATY WILLIAMS	22-00115			Sec Dep Return for Kingfisher	19001171	63040		Security Deposit Refund			\$100.00
									Sub-Total			\$200.00
1452	NICOR	22827083027053			Nicor Hoover Shop	19001171	63090		Natural Gas			\$53.34
1452	NICOR	24614203628053			Nicor Blazing Star	19001171	63090		Natural Gas			\$91.71
1452	NICOR	28235299733053			Nicor Moonseed	19001171	63090		Natural Gas			\$75.14
1452	NICOR	30831034894053			Nicor Kingfisher	19001171	63090		Natural Gas			\$71.65
1452	NICOR	50980197128053			Nicor Meadowhawk Lodge	19001171	63090		Natural Gas			\$65.23
1452	NICOR	72389374124053			Nicor Hoover Residence	19001171	63090		Natural Gas			\$53.40
1452	NICOR	88551401149053			Nicor Hoover Maintenance	19001171	63090		Natural Gas			\$120.01
									Sub-Total			\$530.48

Hoover

Hoover	2047	COMED	07936730150531 22	ComEd-Hoover Multiple	19001171 63100	Electric	\$912.03
						Sub-Total	\$912.03
	51	SYNCB/AMAZON	1YRG-1D9N- 1VDG	Hoover-Shop-Wet Mops	19001171 63110	Shop Supplies	\$26.56
						Sub-Total	\$26.56
	236	CENTRAL LIMESTONE CO INC	29049	Hoover Grounds-Gravel	19001171 68580	Grounds and Maintenance	\$572.91
						Sub-Total	\$572.91
					Hoover	Total	\$2,241.98
						Grand Total	\$13,012.36



05/24/2022 11:10
jgranholm

Kendall County
INVOICE ENTRY PROOF LIST

CLERK: jgranholm BATCH: 2521

NEW INVOICES

1 P
| apinvent

VENDOR REMIT NAME	INVOICE	PO	CHECK RUN	NET AMOUNT	EXCEEDS PO BY	PO BALANCE	CHK/WIRE
HELD INVOICES							
107 00000 AUTOMOTIVE SPECI	25334		053122F	835.90	.00	.00	
CASH 000008 2022/06 INV 05/24/2022	SEP-CHK: Y DISC: .00						
ACCT 1Y210 DEPT 11 DUE 05/31/2022	DESC: Drain valve, hub seals-2009 Ford F250				19001183 62160	835.90	1099:
CONDITIONS THAT PREVENT POSTING INVOICE 107/28183							
* Invoice must be approved or voided to post.							
158 00000 BLOOD HOUND	00196502		053122F	822.50	.00	.00	
CASH 000008 2022/06 INV 05/24/2022	SEP-CHK: Y DISC: .00						
ACCT 1Y210 DEPT 11 DUE 05/31/2022	DESC: Pickerill Line locating				191311 70330	822.50	1099:
CONDITIONS THAT PREVENT POSTING INVOICE 158/28182							
* Invoice must be approved or voided to post.							
2 HELD INVOICES				1,658.40	TOTAL		
PENDING UNPAID INVOICES							
51 00001 AMAZON.COM	1YRG-1D9N-W1TG		053122F	265.44	.00	.00	
CASH 000008 2022/06 INV 05/16/2022	SEP-CHK: Y DISC: .00						
ACCT 1Y210 DEPT 11 DUE 06/15/2022	DESC: Fly tarp, fly masks-Ellis Animal Care				19001167 63000	265.44	1099:
CONDITIONS THAT PREVENT POSTING INVOICE 51/27824							
* Invoice must be approved or voided to post.							
51 00001 AMAZON.COM	1407-LXG9-J1HL		053122F	137.57	.00	.00	
CASH 000008 2022/06 INV 05/14/2022	SEP-CHK: Y DISC: .00						
ACCT 1Y210 DEPT 11 DUE 06/13/2022	DESC: Pollinator Fest Supplies				190011 62000	137.57	1099:
CONDITIONS THAT PREVENT POSTING INVOICE 51/27825							
* Invoice must be approved or voided to post.							
51 00001 AMAZON.COM	11LK-TXCR-03GF		053122F	18.74	.00	.00	
CASH 000008 2022/06 INV 05/15/2022	SEP-CHK: Y DISC: .00						
ACCT 1Y210 DEPT 11 DUE 06/14/2022	DESC: School Programs-White School Glue				19001176 63030	18.74	1099:
CONDITIONS THAT PREVENT POSTING INVOICE 51/27826							



NEW INVOICES

* Invoice must be approved or voided to post.

51 00001 AMAZON.COM 1E67-0041-JGCM 053122F 75.21 .00
CASH 000008 2022/06 INV 05/14/2022 SEP-CHK: Y DISC: .00
ACCT 1Y210 DEPT 11 DUE 06/13/2022 DESC:Dinsoaur themed supplies for NB end of year
CONDITIONS THAT PREVENT POSTING INVOICE 51/27827

* Invoice must be approved or voided to post.

51 00001 AMAZON.COM 1NMR-DECT-FN6P 053122F 111.40 .00
CASH 000008 2022/06 INV 05/14/2022 SEP-CHK: Y DISC: .00
ACCT 1Y210 DEPT 11 DUE 06/13/2022 DESC:Education Dept Uniforms
CONDITIONS THAT PREVENT POSTING INVOICE 51/27828

* Invoice must be approved or voided to post.

51 00001 AMAZON.COM 1YRG-1D9N-LC74 053122F 564.23 .00
CASH 000008 2022/06 INV 05/16/2022 SEP-CHK: Y DISC: .00
ACCT 1Y210 DEPT 11 DUE 06/15/2022 DESC:Camp supplies
CONDITIONS THAT PREVENT POSTING INVOICE 51/27829

* Invoice must be approved or voided to post.

51 00001 AMAZON.COM 17DH-LGXF-RFPW 053122F 46.98 .00
CASH 000008 2022/06 INV 05/15/2022 SEP-CHK: Y DISC: .00
ACCT 1Y210 DEPT 11 DUE 06/14/2022 DESC:Truck uplifters, insulated medical case
CONDITIONS THAT PREVENT POSTING INVOICE 51/27830

* Invoice must be approved or voided to post.

51 00001 AMAZON.COM 1YRG-1D9N-1VDG 053122F 26.56 .00
CASH 000008 2022/06 INV 05/15/2022 SEP-CHK: Y DISC: .00
ACCT 1Y210 DEPT 11 DUE 06/14/2022 DESC:Hoover-Shop-Wet Mops
CONDITIONS THAT PREVENT POSTING INVOICE 51/27831

* Invoice must be approved or voided to post.



VENDOR REMIT NAME	INVOICE	PO	CHECK RUN	NET AMOUNT	EXCEEDS PO BY	PO BALANCE	CHK/WIRE
00001 AMAZON.COM	<u>1MLN-J7N4-03F3</u>		053122F	4.75	.00	.00	
CASH <u>000008</u>	INV 05/17/2022	SEP-CHK: Y	DISC: .00				
ACCT <u>1Y210</u>	DUE 06/16/2022	DESC:Curious George Book for Summer Camp			<u>19001177 63030</u>		4.75 1099:
CONDITIONS THAT PREVENT POSTING INVOICE							
* Invoice must be approved or voided to post.							
00001 AMAZON.COM	<u>1Y66-MLGV-0V3Y</u>		053122F	20.75	.00	.00	
CASH <u>000008</u>	INV 05/18/2022	SEP-CHK: Y	DISC: .00				
ACCT <u>1Y210</u>	DUE 06/17/2022	DESC:Amazon-Beverage Dispenser			<u>190011 62000</u>		20.75 1099:
CONDITIONS THAT PREVENT POSTING INVOICE							
* Invoice must be approved or voided to post.							
00001 AMEREN IP	<u>2786444006053122</u>		053122F	39.75	.00	.00	
CASH <u>000008</u>	INV 05/16/2022	SEP-CHK: Y	DISC: .00				
ACCT <u>1Y210</u>	DUE 07/15/2022	DESC:Ameren-Millbrook S			<u>190011 63510</u>		39.75 1099:
CONDITIONS THAT PREVENT POSTING INVOICE							
* Invoice must be approved or voided to post.							
00000 BARRETT'S ECOWAT	<u>0010381053122</u>		053122F	521.20	.00	.00	
CASH <u>000008</u>	INV 05/20/2022	SEP-CHK: Y	DISC: .00				
ACCT <u>1Y210</u>	DUE 06/20/2022	DESC:Ellis Water service, glass jugs			<u>19001160 62270</u>		521.20 1099:
CONDITIONS THAT PREVENT POSTING INVOICE							
* Invoice must be approved or voided to post.							
00000 CENTRAL LIMESTON	<u>29049</u>		053122F	572.91	.00	.00	
CASH <u>000008</u>	INV 05/09/2022	SEP-CHK: Y	DISC: .00				
ACCT <u>1Y210</u>	DUE 05/31/2022	DESC:Hoover Grounds-Gravel			<u>19001171 68580</u>		572.91 1099:
CONDITIONS THAT PREVENT POSTING INVOICE							
* Invoice must be approved or voided to post.							
00000 DEKANE EQUIPMENT	<u>023674</u>		053122F	3,199.00	.00	.00	
CASH <u>000008</u>	INV 05/20/2022	SEP-CHK: Y	DISC: .00				
ACCT <u>1Y210</u>	DUE 05/31/2022	DESC:Cub Cadet Tractor Purchase			<u>19001183 62160</u>		3,199.00 1099:



05/24/2022 11:10
jgranholm

Kendall County
INVOICE ENTRY PROOF LIST

CLERK: jgranholm BATCH: 2521

VENDOR REMIT NAME INVOICE

NEW INVOICES

PO CHECK RUN

NET AMOUNT

EXCEEDS PO BY

PO BALANCE CHK/WIRE

4
lapinvent

CONDITIONS THAT PREVENT POSTING INVOICE	413/27945								
* Invoice must be approved or voided to post.									
695 00000 GROUND EFFECTS I 468379-000	053122F	142.40	.00						
CASH 000008 2022/06 INV 05/17/2022 SEP-CHK: Y DISC: .00									
ACCT 1Y210 2022/06 DUE 05/31/2022 DESC:Road Gravel for Hoover Garden				190011 68500	142.40	1099:			
CONDITIONS THAT PREVENT POSTING INVOICE	695/27881								
* Invoice must be approved or voided to post.									
695 00000 GROUND EFFECTS I 468388-000	053122F	142.40	.00						
CASH 000008 2022/06 INV 05/17/2022 SEP-CHK: Y DISC: .00									
ACCT 1Y210 2022/06 DUE 05/31/2022 DESC:Gravel for Hoover Garden				190011 68500	142.40	1099:			
CONDITIONS THAT PREVENT POSTING INVOICE	695/27882								
* Invoice must be approved or voided to post.									
695 00000 GROUND EFFECTS I 468399-000	053122F	106.04	.00						
CASH 000008 2022/06 INV 05/17/2022 SEP-CHK: Y DISC: .00									
ACCT 1Y210 2022/06 DUE 05/31/2022 DESC:Mulch for Hoover Garden				190011 68500	106.04	1099:			
CONDITIONS THAT PREVENT POSTING INVOICE	695/27883								
* Invoice must be approved or voided to post.									
695 00000 GROUND EFFECTS I 468416-000	053122F	159.06	.00						
CASH 000008 2022/06 INV 05/17/2022 SEP-CHK: Y DISC: .00									
ACCT 1Y210 2022/06 DUE 05/31/2022 DESC:Mulch for Hoover Garden				190011 68500	159.06	1099:			
CONDITIONS THAT PREVENT POSTING INVOICE	695/27884								
* Invoice must be approved or voided to post.									
695 00000 GROUND EFFECTS I 468426	053122F	159.06	.00						
CASH 000008 2022/06 INV 05/17/2022 SEP-CHK: Y DISC: .00									
ACCT 1Y210 2022/06 DUE 05/31/2022 DESC:Mulch for Hoover Garden				190011 68500	159.06	1099:			
CONDITIONS THAT PREVENT POSTING INVOICE	695/27885								
* Invoice must be approved or voided to post.									



05/24/2022 11:10
jgranholm

Kendall County
INVOICE ENTRY PROOF LIST

BATCH: 2521

CLERK: jgranholm

INVOICE

PO

CHECK RUN

NET AMOUNT

EXCEEDS PO BY

PO BALANCE CHK/WIRE

5
lapinvent

NEW INVOICES

VENDOR REMIT NAME

BATCH: 2521

INVOICE

PO

CHECK RUN

NET AMOUNT

EXCEEDS PO BY

PO BALANCE CHK/WIRE

695 00000 GROUND EFFECTS I 468436-000 053122F 79.53 .00
 CASH 000008 2022/06 INV 05/17/2022 SEP-CHK: Y DISC: .00
 ACCT 1Y210 DEPT 11 DUE 05/31/2022 DESC:Mulch for Hoover Garden
 CONDITIONS THAT PREVENT POSTING INVOICE 695/27886

* Invoice must be approved or voided to post.

1020 00000 ILLINOIS STATE P 05718 053122F 40.00 .00
 CASH 000008 2022/06 INV 04/30/2022 SEP-CHK: Y DISC: .00
 ACCT 1Y210 DEPT 11 DUE 06/15/2022 DESC:Background Checks
 CONDITIONS THAT PREVENT POSTING INVOICE 1020/27871

* Invoice must be approved or voided to post.

1091 00000 K & K WELL DRILL 32113 053122F 148.00 .00
 CASH 000008 2022/06 INV 05/16/2022 SEP-CHK: Y DISC: .00
 ACCT 1Y210 DEPT 11 DUE 05/31/2022 DESC:4 containers of hydrogen peroxide-5 gallon-Ellis
 CONDITIONS THAT PREVENT POSTING INVOICE 1091/28059

* Invoice must be approved or voided to post.

1152 00000 KENDALL PLUMBING 99300499268 053122F 1,250.00 .00
 CASH 000008 2022/06 INV 05/19/2022 SEP-CHK: Y DISC: .00
 ACCT 1Y210 DEPT 11 DUE 05/31/2022 DESC:CPVC Repair at Hoover
 CONDITIONS THAT PREVENT POSTING INVOICE 1152/27947

* Invoice must be approved or voided to post.

1153 00000 KENDALL CO HIGHW Welcome Signs 053122F 300.00 .00
 CASH 000008 2022/06 INV 05/17/2022 SEP-CHK: Y DISC: .00
 ACCT 1Y210 DEPT 11 DUE 05/31/2022 DESC>Welcome Signs
 CONDITIONS THAT PREVENT POSTING INVOICE 1153/28169

* Invoice must be approved or voided to post.

1323 00000 MENARDS 42145 053122F 22.68 .00
 CASH 000008 2022/06 INV 05/07/2022 SEP-CHK: Y DISC: .00
 ACCT 1Y210 DEPT 11 DUE 05/31/2022 DESC:Carabiner, screw-Ellis Barn

CLERK: jgranholm BATCH: 2521 NEW INVOICES

VENDOR REMIT NAME	INVOICE	PO	CHECK RUN	NET AMOUNT	EXCEEDS PO BY	PO BALANCE	CHK/WIRE
-------------------	---------	----	-----------	------------	---------------	------------	----------

CONDITIONS THAT PREVENT POSTING INVOICE 1323/27870

* Invoice must be approved or voided to post.

1323	00000 MENARDS	42599	053122F	148.44	.00	.00	
------	---------------	-------	---------	--------	-----	-----	--

CASH 000008	2022/06	INV 05/12/2022	SEP-CHK: Y	DISC: .00	190011	68500	64.55	1099:
ACCT 1Y210	DEPT 11	DUE 05/31/2022	DESC:Menards Grounds Supplies, Hoover Garden		19001183	63110	83.89	1099:

CONDITIONS THAT PREVENT POSTING INVOICE 1323/27896

* Invoice must be approved or voided to post.

1323	00000 MENARDS	43014	053122F	133.46	.00	.00	
------	---------------	-------	---------	--------	-----	-----	--

CASH 000008	2022/06	INV 05/16/2022	SEP-CHK: Y	DISC: .00	190011	68500	133.46	1099:
ACCT 1Y210	DEPT 11	DUE 05/31/2022	DESC:Menards-Wood for Hoover Garden planters		190011	68500		1099:

CONDITIONS THAT PREVENT POSTING INVOICE 1323/27952

* Invoice must be approved or voided to post.

1323	00000 MENARDS	43101	053122F	55.29	.00	.00	
------	---------------	-------	---------	-------	-----	-----	--

CASH 000008	2022/06	INV 05/17/2022	SEP-CHK: Y	DISC: .00	190011	68500	55.29	1099:
ACCT 1Y210	DEPT 11	DUE 05/31/2022	DESC:Menards-Hoover Garden Supplies		190011	68500		1099:

CONDITIONS THAT PREVENT POSTING INVOICE 1323/28093

* Invoice must be approved or voided to post.

1452	00000 NICOR	85662610121053122	053122F	161.20	.00	.00	
------	-------------	-------------------	---------	--------	-----	-----	--

CASH 000008	2022/06	INV 05/10/2022	SEP-CHK: Y	DISC: .00	19001183	63090	161.20	1099:
ACCT 1Y210	DEPT 11	DUE 06/27/2022	DESC:Nicor Millbrook S		19001183	63090		1099:

CONDITIONS THAT PREVENT POSTING INVOICE 1452/27872

* Invoice must be approved or voided to post.

1452	00000 NICOR	22827083027053122	053122F	53.34	.00	.00	
------	-------------	-------------------	---------	-------	-----	-----	--

CASH 000008	2022/06	INV 05/12/2022	SEP-CHK: Y	DISC: .00	19001171	63090	53.34	1099:
ACCT 1Y210	DEPT 11	DUE 06/28/2022	DESC:Nicor Hoover Shop		19001171	63090		1099:

CONDITIONS THAT PREVENT POSTING INVOICE 1452/27873

* Invoice must be approved or voided to post.



CLERK: jgranholm BATCH: 2521

NEW INVOICES

VENDOR REMIT NAME	INVOICE	PO	CHECK RUN	NET AMOUNT	EXCEEDS PO BY	PO BALANCE	CHK/WIRE
1452 00000 NICOR	28235299733053122		053122F	75.14	.00	.00	
CASH 000008 ACCT 1Y210	INV 05/12/2022 DUE 06/28/2022	SEP-CHK: Y DESC:Nicor Moonseed	DISC: .00		19001171 63090	75.14	1099:
CONDITIONS THAT PREVENT POSTING INVOICE 1452/27874							
* Invoice must be approved or voided to post.							
1452 00000 NICOR	72389374124053122		053122F	53.40	.00	.00	
CASH 000008 ACCT 1Y210	INV 05/12/2022 DUE 06/03/2022	SEP-CHK: Y DESC:Nicor Hoover Residence	DISC: .00		19001171 63090	53.40	1099:
CONDITIONS THAT PREVENT POSTING INVOICE 1452/27875							
* Invoice must be approved or voided to post.							
1452 00000 NICOR	88551401149053122		053122F	120.01	.00	.00	
CASH 000008 ACCT 1Y210	INV 05/12/2022 DUE 06/28/2022	SEP-CHK: Y DESC:Nicor Hoover Maintenance	DISC: .00		19001171 63090	120.01	1099:
CONDITIONS THAT PREVENT POSTING INVOICE 1452/27876							
* Invoice must be approved or voided to post.							
1452 00000 NICOR	30831034894053122		053122F	71.65	.00	.00	
CASH 000008 ACCT 1Y210	INV 05/12/2022 DUE 06/28/2022	SEP-CHK: Y DESC:Nicor Kingfisher	DISC: .00		19001171 63090	71.65	1099:
CONDITIONS THAT PREVENT POSTING INVOICE 1452/27877							
* Invoice must be approved or voided to post.							
1452 00000 NICOR	50980197128053122		053122F	65.23	.00	.00	
CASH 000008 ACCT 1Y210	INV 05/12/2022 DUE 06/28/2022	SEP-CHK: Y DESC:Nicor Meadowhawk Lodge	DISC: .00		19001171 63090	65.23	1099:
CONDITIONS THAT PREVENT POSTING INVOICE 1452/27878							
* Invoice must be approved or voided to post.							
1452 00000 NICOR	87946110001053122		053122F	234.10	.00	.00	
CASH 000008 ACCT 1Y210	INV 05/11/2022 DUE 06/28/2022	SEP-CHK: Y DESC:Nicor Harris	DISC: .00		19001183 63090	234.10	1099:



CONDITIONS THAT PREVENT POSTING INVOICE 1452/27879
* Invoice must be approved or voided to post.

1452 00000 NICOR 24614203628053122 053122F 91.71 .00
CASH 000008 INV 05/11/2022 SEP-CHK: Y DISC: .00
ACCT 1Y210 DEPT 11 DUE 06/28/2022 DESC:Nicor Blazing Star 19001171 63090 91.71 1099:

CONDITIONS THAT PREVENT POSTING INVOICE 1452/27880
* Invoice must be approved or voided to post.

1883 00000 WATER PRODUCTS-A 0309257 053122F 148.40 .00
CASH 000008 INV 05/17/2022 SEP-CHK: Y DISC: .00
ACCT 1Y210 DEPT 11 DUE 05/31/2022 DESC:Equipment/supplies for Hobbit Tunnel repairs 190011 68500 148.40 1099:

CONDITIONS THAT PREVENT POSTING INVOICE 1883/27823
* Invoice must be approved or voided to post.

2047 00000 COMED 0793673015053122 053122F 912.03 .00
CASH 000008 INV 05/06/2022 SEP-CHK: Y DISC: .00
ACCT 1Y210 DEPT 11 DUE 06/23/2022 DESC:ComEd-Hoover Multiple 19001171 63100 912.03 1099:

CONDITIONS THAT PREVENT POSTING INVOICE 2047/27835
* Invoice must be approved or voided to post.

2047 00000 COMED 9361548011053122 053122F 141.90 .00
CASH 000008 INV 05/16/2022 SEP-CHK: Y DISC: .00
ACCT 1Y210 DEPT 11 DUE 07/01/2022 DESC:ComEd Ellis House 19001160 62270 141.90 1099:

CONDITIONS THAT PREVENT POSTING INVOICE 2047/27951
* Invoice must be approved or voided to post.

2057 00000 MATTHEW CAVINESS 12022038 053122F 350.00 .00
CASH 000008 INV 05/16/2022 SEP-CHK: Y DISC: .00
ACCT 1Y210 DEPT 11 DUE 05/31/2022 DESC:Trim and shoes for horses-Ellis 19001164 63020 350.00 1099:

CONDITIONS THAT PREVENT POSTING INVOICE 2057/28058
* Invoice must be approved or voided to post.



CLERK: jgranholm BATCH: 2521

VENDOR REMIT NAME	INVOICE	PO	CHECK RUN	NET AMOUNT	EXCEEDS PO BY	PO BALANCE	CHK/WIRE
3630 00000 JUSTINE SKILLMAN <u>RecPro_#7240</u>	053122F		053122F	185.00	.00	.00	
CASH <u>000008</u> 2022/06 INV 05/11/2022 SEP-CHK: Y DISC: .00							
ACCT <u>1Y210</u> DEPT 11 DUE 05/31/2022 DESC:Refund for Nature Warriors Camp					<u>19001177 63040</u>	185.00	1099:
CONDITIONS THAT PREVENT POSTING INVOICE 3630/27833							
* Invoice must be approved or voided to post.							
3631 00000 MARCELA PEREA <u>22-00141</u>	053122F		053122F	100.00	.00	.00	
CASH <u>000008</u> 2022/06 INV 05/20/2022 SEP-CHK: Y DISC: .00							
ACCT <u>1Y210</u> DEPT 11 DUE 05/31/2022 DESC:Sec Dep Return-Moonseed					<u>19001171 63040</u>	100.00	1099:
CONDITIONS THAT PREVENT POSTING INVOICE 3631/27949							
* Invoice must be approved or voided to post.							
3633 00000 KATY WILLIAMS <u>22-00115</u>	053122F		053122F	100.00	.00	.00	
CASH <u>000008</u> 2022/06 INV 05/20/2022 SEP-CHK: Y DISC: .00							
ACCT <u>1Y210</u> DEPT 11 DUE 05/31/2022 DESC:Sec Dep Return for Kingfisher					<u>19001171 63040</u>	100.00	1099:
CONDITIONS THAT PREVENT POSTING INVOICE 3633/27948							
* Invoice must be approved or voided to post.							
44 PENDING UNPAID INVOICES				11,353.96	TOTAL		
0 INVOICE(S)				.00	REPORT POST TOTAL		
					REPORT TOTALS .00		

Kendall County Forest Preserve
Income Statement
For Period Ended 4/30/2022

5 Month Budget Percent = 41.7%

FOREST PRESERVES & PROGRAMS

	Current Year FY22		Prior Year FY21		YTD Variance	
	Budget	YTD	Budget	YTD	\$ Change	% Change
Beginning Balance	\$	470,609	\$	171,805	\$	298,803
Revenue						
Revenue - Administration		781,540	969,163	229,938	-200,645	-87%
Revenue - Ellis House & Equestrian Center	64.9%	155,024	139,822	48,678	-3,198	-7%
Revenue - Hoover FP	12.9%	39,300	35,031	9,470	23,347	247%
Revenue - Env. Education	3.3%	197,780	154,112	89,614	43,119	48%
Revenue - Natural Area Volunteers	16.4%	-	-	-	0	
Revenue - Grounds & Natural Resources	0.0%	29,000	29,171	970	2,946	304%
Revenue - Pickerill Pigott FP	2.4%	750	12,584	5,171	-5,171	-100%
Total Revenue	100.0%	1,203,394	1,339,883	383,841	(139,602)	-36%
Expenditure						
Expenditure - Administration	32.0%	385,515	358,479	151,068	29,048	19%
Expenditure - Ellis House & Equestrian Center	15.7%	189,032	182,402	61,967	6,329	10%
Expenditure - Hoover FP	18.4%	220,843	201,674	75,911	12,105	16%
Expenditure - Env. Education	15.0%	180,633	170,620	65,783	-4,583	-7%
Expenditure - Natural Area Volunteers	0.0%	-	-	-	0	
Expenditure - Grounds & Natural Resources	18.3%	219,921	203,939	72,774	29,354	40%
Expenditure - Pickerill Pigott FP	0.6%	7,450	7,450	3,427	1,951	57%
Total Expenditure	100.0%	1,203,394	1,124,564	430,929	74,204	17%
ENDING BAL	\$	470,609	\$	124,717	\$	84,997
Surplus/(Deficit)	\$	-	\$	(47,088)	\$	(213,806)

Kendall County Forest Preserve
Income Statement
For Period Ended 4/30/2022

5 Month Budget Percent = 41.7%

FOREST PRESERVE CATEGORIES

	Current Year FY22		Prior Year FY21		YTD Variance	
	Budget	YTD	Budget	YTD	\$ Change	% Change
Beginning Balance						
Revenue						
Property Tax	660,740	-	640,646	-	0	0.0%
Interest Income	200	71	591	59	12	7.7%
Other Income	41,261	17,445	34,350	8,755	8,689	17.7%
Donations	8,900	2,742	8,950	-	2,742	0.0%
Rental Revenue	37,750	32,217	43,623	13,221	18,996	14.4%
Program Revenue	337,404	174,213	282,834	134,192	40,021	30%
Grants	-	-	-	-	-	0.0%
Farm License Revenue	95,379	7,725	95,379	5,714	2,011	5.3%
Security Deposits	18,800	8,276	16,217	5,760	2,516	14.0%
Credit Card Revenue	2,960	1,551	2,219	1,053	498	34.6%
Transfers In			215,074	215,086	-12	0.0%
Total Revenue	1,203,394	244,238	1,339,883	383,841	(139,602)	-36%
Expenditure						
Personnel	673,924	252,909	671,755	266,327	-13,418	-5%
Benefits	268,734	129,572	231,244	96,964	32,608	34%
Contractual	58,008	31,394	51,868	14,890	16,505	111%
Commodities	120,800	62,537	111,630	37,607	24,930	66%
Other	81,928	28,721	58,067	15,142	13,579	90%
Total Expenditure	1,203,394	505,133	1,124,564	430,929	74,204	17%
ENDING BAL	\$ 470,609	\$ 209,714	\$ 387,124	\$ 124,717	\$ 84,997	68.2%
Surplus/(Deficit)	\$ -	\$ (260,895)	\$ 215,319	\$ (47,088)	\$ (213,806)	

Kendall County Forest Preserve
Income Statement
For Period Ended 4/30/2022

5 Month Budget Percent = 41.7%

ADMINISTRATION

	Current Year FY22		Prior Year FY21		YTD Variance	
	Budget	YTD	Budget	YTD	\$ Change	% Change
Revenue						
Property Tax	660,740	-	640,646	-	12	20%
Interest Income	200	71	591	59	9,179	114%
Other Income	17,261	17,204	9,754	8,025	2,742	35%
Donations	5,000	2,742	5,500	-	2,011	47%
Farm License Revenue	95,379	7,725	95,379	5,714	498	
Security Deposit Revenue						
Credit Card Revenue	2,960	1,551	2,219	1,053		
Program Revenue						
Transfers In						
Total Revenue	781,540	29,292	969,163	229,938	(200,645)	-87%
	100.0%	3.7%	100.0%	23.7%		
Expenditure						
Personnel	178,452	68,567	193,426	80,764	-12,198	-15%
Benefits	140,509	81,729	111,829	59,644	22,086	37%
Contractual	28,308	20,562	22,418	5,316	15,246	287%
Commodities	16,200	6,560	19,306	5,343	1,217	23%
Other	22,046	2,697	11,500	-	2,697	
Total Expenditure	385,515	180,115	358,479	151,068	29,048	19%
	100.0%	46.7%	42.1%			
Surplus/(Deficit)	\$ 396,025	\$ (150,823)	\$ 610,684	\$ 78,870		

Kendall County Forest Preserve
Income Statement
For Period Ended 4/30/2022

5 Month Budget Percent = 41.7%

ELLIS HOUSE & EQUESTRIAN CENTER

	Current Year FY22		Prior Year FY21		YTD Variance	
	Budget	YTD	Budget	YTD	\$ Change	% Change
Revenue						
Donations	-	-	200	-		
Security Deposit	12,500	4,000	9,600	4,100	-100	
Credit Card Revenue	-	-	-	-		
Program Revenue	142,524	41,480	130,022	44,578	-3,098	-7%
Total Revenue	155,024	45,480	139,822	48,678	(3,198)	-7%
Expenditure						
Personnel	112,992	44,459	152,311	43,955	504	1%
Employee Benefits	13,490	4,259	15,885	4,037	223	6%
Contractual	11,200	2,850	11,200	2,167	683	32%
Commodities	29,350	12,895	24,290	7,583	5,312	70%
Other	22,000	3,834	19,000	4,226	-392	-9%
Total Expenditure	189,032	68,296	222,686	61,967	6,329	10%
Surplus/(Deficit)	\$ (34,008)	\$ (22,816)	\$ (82,864)	\$ (13,289)		

Kendall County Forest Preserve
Income Statement
For Period Ended 4/30/2022

5 Month Budget Percent = 41.7%

HOOVER FOREST PRESERVE

	Current Year FY22		Prior Year FY21		YTD Variance	
	Budget	YTD	Budget	YTD	\$ Change	% Change
Revenue						
Donations	-	-	28,414	7,810	20,732	265%
Rental Revenue	33,000	28,542	6,617	1,660	2,616	158%
Security Deposit Rev	6,300	4,276	-	-	-	-
Program Revenue	-	-	-	-	-	-
Total Revenue	39,300	32,817	35,031	9,470	23,347	247%
Expenditure						
Personnel	127,330	44,062	119,066	46,331	-2,269	-5%
Employee Benefits	43,331	16,791	38,691	14,302	2,489	17%
Contractual	-	-	-	-	-	-
Commodities	39,100	23,864	37,300	14,404	9,461	66%
Other	11,082	3,298	6,617	875	2,424	277%
Total Expenditure	220,843	88,016	201,674	75,911	12,105	16%
Surplus/(Deficit)	\$ (181,543)	\$ (55,198)	\$ (166,643)	\$ (66,441)		

Kendall County Forest Preserve
Income Statement
For Period Ended 4/30/2022

5 Month Budget Percent = 41.7%

ENVIRONMENTAL EDUCATION

	Current Year FY22		Prior Year FY21		YTD Variance	
	Budget	YTD	Budget	YTD	\$ Change	% Change
Revenue						
Donations						
Security Deposit						
Credit Card Revenue						
Program Revenue						
Total Revenue						
	1.5%					
		2,900	1,300	-		
	96.5%	194,880	152,812	89,614	43,119	48%
	100.0%	197,780	132,733	89,614	43,119	48%
	82.2%	148,423	143,304	58,079	-2,513	-4%
	11.1%	20,050	19,057	5,950	-1,032	-17%
Total Expenditure						
	3.0%	5,450	2,559	224	492	220%
	3.7%	6,700	5,700	1,530	-1,530	
	100.0%	180,633	61,200	65,783	(4,583)	-7%
Surplus/(Deficit)						
		\$ 17,147	\$ 71,533	\$ 23,831		

Kendall County Forest Preserve
Income Statement
For Period Ended 4/30/2022

5 Month Budget Percent = 41.7%

GROUPS & NATURAL RESOURCES

	Current Year FY22		Prior Year FY21		YTD Variance	
	Budget	YTD	Budget	YTD	\$ Change	% Change
Revenue						
Other Income		241	24,596	730	-489	-67%
Donations	1,000	-	1,950	-		
Grants	-	-	-	-		
Credit Card Revenue						
Rental Revenue	4,000	3,675	2,625	240	3,435	1431%
Total Revenue	29,000	3,916	29,171	970	2,946	304%
Expenditure						
Personnel	106,727	40,255	103,932	37,198	3,057	8%
Employee Benefits	51,344	21,875	45,452	13,032	8,843	68%
Contractual	18,500	7,982	18,250	7,407	576	8%
Commodities	23,250	13,125	20,725	6,627	6,498	98%
Other	20,100	18,892	15,250	8,512	10,381	122%
Total Expenditure	219,921	102,129	203,609	72,774	29,354	40%
Surplus/(Deficit)	\$ (190,921)	\$ (98,213)	\$ (174,438)	\$ (71,804)		

Kendall County Forest Preserve
Income Statement
For Period Ended 4/30/2022

5 Month Budget Percent = 41.7%

PICKERILL PIGOTT FP

Revenue
Donations
Other Income
Rental Revenue
Security Deposit
Total Revenue
Expenditure
Personnel
Employee Benefits
Contractual
Commodities
Other
Total Expenditure
Surplus/(Deficit)

	Current Year FY22		Prior Year FY21		YTD Variance	
	Budget	YTD	%	Budget	YTD	%
	-	-		-	-	
	-	-		-	-	
	750	-		12,584	5,171	41.1%
	-	-		-	-	-100%
	750	-	100.0%	12,584	5,171	41.1%
	-	-		-	-	
	-	-		-	-	
	7,450	5,377	72.2%	7,450	3,427	46.0%
	-	-		-	-	
	7,450	5,377	72.2%	7,450	3,427	46.0%
	\$ (6,700)	\$ (5,377)		\$ 5,134	\$ 1,744	
					1,951	57%
					1,951	57%

Forest Preserve District Debt Service - Series 2003/2012
Fund 1902
For Period Ended 4/30/2022

5 Month Budget % = 41.7%

ACCOUNT & DESCRIPTION	Budget 2022	Actual YTD	% of Budget
Beginning Balance	\$ 937,583	\$ 937,583	
REVENUE			
190211 41010 Current Tax	442,900		0.0%
190211 41350 Interest Income	250	117	46.7%
Total Revenue	443,150	117	0.0%
EXPENDITURE			
190211 68640 Fiscal Agent Fee	1,057		0.0%
190211 68650 Debt Service - Interest 2012	18,975	12,525	66.0%
190211 68700 Debt Service - Principal 2012	405,000	405,000	100.0%
Total Expenditure	425,032	417,525	98.2%
Ending Balance	\$ 955,701	\$ 520,175	
Revenue over/(under) Expenditure	\$ 18,118		

Forest Preserve District Debt Service - Series 2007/15/16/17
Fund 1903
For Period Ended 4/30/2022

5 Month Budget % = **41.7%**

ACCOUNT & DESCRIPTION	Budget 2022	Actual YTD	% of Budget
Beginning Balance	\$ 4,635,395	\$ 4,635,395	
REVENUE			
190311 41010 Current Tax	4,937,318		0.0%
190311 41350 Interest Income	650	249	38.3%
Total Revenue	4,937,968	249	0.0%
EXPENDITURE			
190311 66500 Other Expenditure	475		0.0%
190311 68640 Fiscal Agent Fee	1,107	475	42.9%
190311 68710 Debt Service - Interest 2015	354,040	177,250	50.1%
190311 68720 Debt Service - Principal 2015	40,000	40,000	100.0%
190311 68730 Debt Service - Interest 2016	290,088	146,094	50.4%
190311 68740 Debt Service - Principal 2016	105,000	105,000	100.0%
190311 68750 Debt Service - Interest 2017	477,125	279,250	58.5%
190311 68760 Debt Service - Principal 2017	3,255,000	3,255,000	100.0%
Total Expenditure	4,522,835	4,003,069	88.5%
Ending Balance	\$ 5,050,528	\$ 632,575	
Revenue over/(under) Expenditure	\$ 415,133		

**KCFP Endowment Fund
Fund 1904
For Period Ended 4/30/2022**

5 Month Budget % = 41.7%

<u>ACCOUNT & DESCRIPTION</u>	<u>Budget 2022</u>	<u>Actual YTD</u>	<u>% of Budget</u>
Beginning Balance	\$ 883,179	\$ 883,179	
REVENUE			
190411 41350 Interest Income	6,715	381	5.7%
Total Revenue	6,715	381	5.7%
EXPENDITURE			
190411 62150 Contractual Services	27,625	11,662	42.2%
Total Expenditure	27,625	11,662	42.2%
Ending Balance	<u>\$ 862,269</u>	<u>\$ 871,898</u>	
Revenue over/(under) Expenditure	\$ (20,910)		

**Forest Preserve Capital Fund
Fund 1907
For Period Ended 4/30/2022**

ACCOUNT & DESCRIPTION	5 Month Budget % = 41.7%		
	Budget 2022	Actual YTD	% of Budget
Beginning Balance	\$ 137,986	\$ 286,713	
REVENUE			
190711 40370 Transfer In from OSLAD Fund #1905			
190711 40400 Transfer In from 2021 Bond Proceeds Fund #1912			
190711 41350 Interest Income	100,784	103	0.0%
190711 42490 Other Revenue	5,000		0.0%
190711 43430 Grant Award - Morton Arboretum Landscape	50,000		0.0%
190711 43740 Grant Award - ICECF Land Acquisition	10,000	10,000	100.0%
190711 43770 Grant Award - ICECF K-12 Pollinator	11,000		0.0%
190711 43780 Grant Award - ICECF Pilot Pollinator Meadows	10,000		0.0%
Total Revenue	186,784	10,103	5.4%
EXPENDITURE			
190711 61430 Transfer to Land Cash Fund - Reservation Woods	200,000		0.0%
190711 62160 Equipment Replacement Contingency	33,762	31,244	92.5%
190711 66500 Project Fund Expense	104,121	11,075	10.6%
190711 68500 Project Fund Expenses	275	275	99.9%
190711 68510 Project Fund Expense - ICECF K-12 Pollinator	5,550	4,834	87.1%
190711 68520 Project Fund Expense - ICECF Pilot Pollinator Meadows			
190711 68530 Project Fund Expense - Preserve improvements			
190711 68610 Project Fund Expense - Morton Arboretum Landscape	37,714	19,530	51.8%
Total Expenditure	381,422	66,957	17.6%
Ending Balance	\$ (56,652)	\$ 229,859	
Revenue over/(under) Expenditure	\$ (194,638)		

KCFP Fox River Bluffs Access RTP Grant Fund
Fund 1908
For Period Ended 4/30/2022

5 Month Budget % = 41.7%

ACCOUNT & DESCRIPTION	Budget 2022	Actual YTD	% of Budget
Beginning Balance	\$ 30,300	\$ 30,300	
REVENUE			
190811 42970 Grant Award	30,300		0.0%
Total Revenue	30,300	0	0.0%
EXPENDITURE			
190811 70650 Professional Services	30,300		0.0%
Total Expenditure	30,300	0	0.0%
Ending Balance	<u>\$ 30,300</u>	<u>\$ 30,300</u>	
Revenue over/(under) Expenditure	\$ -		

**FP Land Cash
Fund 1910**

For Period Ended 4/30/2022

5 Month Budget % = **41.7%**

ACCOUNT & DESCRIPTION	Budget 2022	Actual YTD	% of Budget
Beginning Balance	\$ 205,214	\$ 205,214	
REVENUE			
191011 40380 Transfer in From Forest Preserve Capital Fund (1907)			
191011 42490 Other Revenue		50	
191011 42910 Transfer In From Land Cash			
191011 42970 Grant Awards	124,271	124,271	100.0%
Total Revenue	124,271	124,321	100.0%
EXPENDITURE			
191011 61300 Transfer Out to Capital Fund #1907			
191011 67410 Land Acquisition	329,485	135,167	41.0%
Total Expenditure	329,485	135,167	41.0%
Ending Balance	\$ -	\$ 194,369	
Revenue over/(under) Expenditure	\$ (205,214)		

**KCFP Liability Insurance Fund
Fund 1911**

For Period Ended 4/30/2022

5 Month Budget % = 41.7%

ACCOUNT & DESCRIPTION	Budget 2022	Actual YTD	% of Budget
Beginning Balance	\$ 46,300	\$ 46,300	
REVENUE			
191111 40020 Transfer from FP			
191111 40320 Transfer from FP Operating Fund			
191111 41350 Insurance Claim Reimbursement			
191111 42120 Interest Income			
Total Revenue	0		
EXPENDITURE			
191111 68990 Claims/Deductibles	25,000		0.0%
Total Expenditure	25,000	0	0.0%
Ending Balance	\$ 21,300	\$ 46,300	
Revenue over/(under) Expenditure	\$ (25,000)		

**KCFP Series 2021 Bond Proceeds Fund
Fund 1912**

For Period Ended 4/30/2022

5 Month Budget % = 41.7%

ACCOUNT & DESCRIPTION	Budget 2022	Actual YTD	% of Budget
Beginning Balance	\$ 100,919	\$ 100,919	
REVENUE			
191211 41350 Interest Income		13	
191211 42970 Bond Proceeds			
Total Revenue	0	13	
EXPENDITURE			
191211 61370 Transfer to Fox River Bluffs Fund			
191211 61420 Transfer to FP Capital Fund #1907	100,784		0.0%
191211 61440 Transfer to FP Fund 1913			
Total Expenditure	100,784	0	0.0%
Ending Balance	\$ 135	\$ 100,931	
Revenue over/(under) Expenditure	\$ (100,784)		

Forest Preserve District Pickerill-Piggott IDNR-PARC Grant Fund
Fund 1913
For Period Ended 4/30/2022

5 Month Budget % = **41.7%**

ACCOUNT & DESCRIPTION	Budget 2022	Actual YTD	% of Budget
Beginning Balance	\$ 1,062,110	\$ 1,062,110	
REVENUE			
191311 41350 Interest Income	200		0.0%
191311 42970 Grant Award	828,200		0.0%
191311 43800 Transfer from FP Fund 1912			
Total Revenue	828,400	0	0.0%
EXPENDITURE			
191311 70040 Supplies			
191311 70050 Contractual Services			
191311 70060 Consultants			
191311 70330 Construction	1,036,265		0.0%
191311 70650 Professional Services	27,340	8,807	32.2%
Total Expenditure	1,063,605	8,807	0.8%
Ending Balance	\$ 826,905	\$ 1,053,303	
Revenue over/(under) Expenditure	\$ (235,205)		

**Forest Preserve District American Rescue Plan Act (ARPA) Fund
Fund 1914
For Period Ended 4/30/2022**

5 Month Budget % = 41.7%

ACCOUNT & DESCRIPTION	Budget 2022	Actual YTD	% of Budget
Beginning Balance	\$ 7,594	\$ 7,594	
REVENUE			
191411 40390 Kendall County ARPA Fund Revenue	100,000		0.0%
191411 41350 Interest Income			
Total Revenue	100,000	0	0.0%
EXPENDITURE			
191411 51160 Salaries - Part Time	17,280		0.0%
191411 51390 Salaries - Full Time	32,600	12,677	38.9%
191411 61160 IMRF Expense	2,272	992	43.7%
191411 63050 FICA Expense	2,494	753	30.2%
191411 63060 Health Insurance Expense	11,500	5,530	48.1%
191411 68530 Preserve Improvements	36,830	845	2.3%
191411 70330 Construction		(18,930)	
Total Expenditure	102,976	1,868	1.8%
Ending Balance	\$ 4,618	\$ 5,727	
Revenue over/(under) Expenditure	\$ (2,976)		

Forest Preserve District Debt Service - Series 2021
Fund 1915
For Period Ended 4/30/2022

5 Month Budget % = **41.7%**

ACCOUNT & DESCRIPTION	Budget 2022	Actual YTD	% of Budget
Beginning Balance	\$ -	\$ -	
REVENUE			
191511 41010 Current Tax	82,226		0.0%
191511 41350 Interest Income	100		0.0%
Total Revenue	82,326	0	0.0%
EXPENDITURE			
191511 66500 Miscellaneous Expense	475		0.0%
191511 68640 Fiscal Agent Fee	1,107		0.0%
191511 68790 Debt Service - Interest 2021	34,354		0.0%
191511 68800 Debt Service - Principal 2021			
Total Expenditure	35,936	0	0.0%
Ending Balance	\$ 46,390	\$ -	
Revenue over/(under) Expenditure	\$ 46,390		

To: KCFPD Finance Committee

From: Dave Guritz, Director
Antoinette White, Grounds and Natural Resources Division Supervisor

RE: Pickerill Estate House Pre-Construction Projects Progress Report

Date: May 26, 2022

Work has steadily progressed with construction prep activities.

Earlier this year, Grounds Maintenance completed clearing of the septic field area, and all vegetation was cleared from around the perimeter of the estate house. Grounds also completed projects to secure the storage shed.

Final tree and shrub clearing within the construction footprint, carpet removal, and window protection was completed by Matt Kellogg.

The order for the purchase of the two HVAC rooftop units with Trane has been completed under the US Communities - State of Illinois cooperative purchasing agreement today in consultation with the project architect and President Gilmour. The final proposal will be presented to Commission for formal approval at the next Commission meeting.

Grounds Maintenance began demolition of the interior drywall/ceiling demo in the public washroom area to prep for RJ Kuhn's donation of services to demolish and cap existing plumbing fixtures, and to prepare for the Kluber Architects inspection to confirm the walls to be demolished are not load bearing.

I am touching base with Ted McCannon at EDS to get a handle on timeframe for septic design. The EDS proposal included \$425 for engineering signing and sealing, which will not be required by PBZ and the Health Department.

Public/private utility locates and mapping has been completed by JULIE and Bloodhound.

Lighting, flooring, and countertop orders will be placed in June.

The RJ Kuhn questionnaire has been received and forwarded to the State's Attorney's Office.

The District is waiting on final responses from Garbe Iron Works and Dry County Enterprises, Inc.



Proposal

(Valid for 30 days from Proposal date)

**PROPRIETARY AND CONFIDENTIAL PROPERTY OF Trane U.S. Inc.
DISTRIBUTION TO OTHER THAN THE NAMED RECIPIENT IS PROHIBITED**

Prepared For:

Kendall County Forest Preserve District, Kendall
County, Illinois
110 W. Madison Street
Yorkville, IL 60560

Date: May 25, 2022

Proposal Number: R1-30-10006-22-001

State of IL Contract Number: 22-510CPOGS-CPOGS-B-25977

Shipping Address:

Kendall County Highway Department
6780 IL-47
Yorkville, IL 60560

Job Name:

Kendall County Forest Preserve District -
Ken Pickerill Estate House Public Access Project

Delivery Terms:

Freight Allowed and Prepaid - F.O.B. Factory

Payment Terms:

Net 30 Days (Invoiced once shipped)

Trane U.S. Inc. is pleased to provide the following proposal for your review and approval.

Pricing is based on drawings prepared by Kluber, Inc., stamped "Bid Documents" dated January 28, 2022.

Item A: (Qty: 2) Impack Pkgd. Heat Pump Rooftop R-410A (13WC) (RTU-1, 2)

- R-410A convertible heat pump 15 SEER
- 208-230/1/60
- 1-2" Filter frame (Field Installed)
- Hinged Filter Access Door (Field Installed)
- 2 heat/1 coll digital non-programmable (Field Installed)
- Evaporator defrost control (Field Installed)
- Electric heater 208/240/1 (Field Installed)
- Low ambient control kit (Field Installed)
- Lifting lug kit (Field Installed)
- 1st yr Labor warranty whole unit

Not Including: Controls, Start-up, Disconnects, Maintenance Service, Extra belts, sheaves, & motors, Spare filters, Power & control wiring, Owner training, Field testing/Inspection

Total Net Price (Excluding Sales Tax) \$ 12,878.00

Add to provide start-up on above "RTUs"\$ 2,007.00

Tax Status: Taxable <input type="checkbox"/> Exempt <input checked="" type="checkbox"/>	IF EXEMPT PLEASE SUBMIT COMPLETED TAX EXEMPTION CERTIFICATE WITH YOUR SIGNED PROPOSAL OR WITH YOUR PURCHASING DOCUMENTS, KEEP YOUR ORIGINAL ON FILE IN THE OFFICE. YOU WILL BE CHARGED TAX IF A VALID EXEMPTION CERTIFICATE IS NOT ON FILE BEFORE EQUIPMENT, PARTS OR SERVICES ARE PROVIDED. SEE WWW.TAXSITES.COM/STATE-LINKS.HTML FOR TAX FORMS.
---	---

Sincerely,

Mo Alikhan,
Trane U.S. Inc.
7100 South Madison
Willowbrook, IL 60527
Office Phone: (630) 734-3200
Fax: (630) 323-9040
mma

This proposal is subject to your acceptance of the attached Trane terms and conditions.

COVID-19 NATIONAL EMERGENCY CLAUSE

The parties agree that they are entering into this Agreement while the nation is in the midst of a national emergency due to the Covid-19 pandemic ("Covid-19 Pandemic"). With the continued existence of Covid-19 Pandemic and the evolving guidelines and executive orders, it is difficult to determine the impact of the Covid-19 Pandemic on Trane's performance under this Agreement. Consequently, the parties agree as follows:

1. Each party shall use commercially reasonable efforts to perform its obligations under the Agreement and to meet the schedule and completion dates, subject to provisions below;
2. Each party will abide by any federal, state (U.S.), provincial (Canada) or local orders, directives, or advisories regarding the Covid-19 Pandemic with respect to its performance of its obligations under this Agreement and each shall have the sole discretion in determining the appropriate and responsible actions such party shall undertake to so abide or to safeguard its employees, subcontractors, agents and suppliers;
3. Each party shall use commercially reasonable efforts to keep the other party informed of pertinent updates or developments regarding its obligations as the Covid-19 Pandemic situation evolves; and
4. If Trane's performance is delayed or suspended as a result of the Covid-19 Pandemic, Trane shall be entitled to an equitable adjustment to the project schedule and/or the contract price.

CUSTOMER ACCEPTANCE	TRANE ACCEPTANCE
_____ Kendall County Forest Preserve District	Trane U.S. Inc.
_____ David Guritz	_____ Authorized Representative
_____ David Guritz	Evan Kattan Printed Name
_____ Executive Director	_____ Title
Purchase Order _____	
Acceptance Date <u>May 26, 2022</u>	Signature Date _____

TERMS AND CONDITIONS - COMMERCIAL EQUIPMENT

"Company" shall mean Trane U.S. Inc..

1. Acceptance. These terms and conditions are an integral part of Company's offer and form the basis of any agreement (the "Agreement") resulting from Company's proposal (the "Proposal") for the sale of the described commercial equipment and any ancillary services (the "Equipment"). **COMPANY'S TERMS AND CONDITIONS AND EQUIPMENT PRICES ARE SUBJECT TO PERIODIC CHANGE OR AMENDMENT.** The Proposal is subject to acceptance in writing by the party to whom this offer is made or an authorized agent ("Customer") delivered to Company within 30 days from the date of the Proposal. Prices in the Proposal are subject to change at any time upon notice to Customer. If Customer accepts the Proposal by placing an order, without the addition of any other terms and conditions of sale or any other modification, Customer's order shall be deemed acceptance of the Proposal subject to Company's terms and conditions. If Customer's order is expressly conditioned upon Company's acceptance or assent to terms and/or conditions other than those expressed herein, return of such order by Company with Company's terms and conditions attached or referenced serves as Company's notice of objection to Customer's terms and as Company's counteroffer to provide Equipment in accordance with the Proposal and the Company's terms and conditions. If Customer does not reject or object in writing to Company within 10 days, Company's counteroffer will be deemed accepted. Notwithstanding anything to the contrary herein, Customer's acceptance of the Equipment will in any event constitute an acceptance by Customer of Company's terms and conditions. This Agreement is subject to credit approval by Company. Upon disapproval of credit, Company may delay or suspend performance or, at its option, renegotiate prices and/or terms and conditions with Customer. If Company and Customer are unable to agree on such revisions, this Agreement shall be cancelled without any liability.

2. Connected Services. In addition to these terms and conditions, the Connected Services Terms of Service ("Connected Services Terms"), available at <https://www.trane.com/TraneConnectedServicesTerms>, as updated from time to time, are incorporated herein by reference and shall apply to the extent that Company provides Customer with Connected Services, as defined in the Connected Services Terms.

3. Title and Risk of Loss. All Equipment sales with destinations to Canada or the U.S. shall be made as follows: FOB Company's U.S. manufacturing facility or warehouse (full freight allowed). Title and risk of loss or damage to Equipment will pass to Customer upon tender of delivery of such to carrier at Company's U.S. manufacturing facility or warehouse.

4. Pricing and Taxes. Within thirty (30) days following Customer acceptance of the Proposal without addition of any other terms and conditions of sale or any modification, Customer shall provide notification of release for immediate production at Company's factory. Prices for Equipment are subject to change at any time prior to shipment to reflect any cost increases related to the manufacture, supply, and shipping of Equipment. This includes, but is not limited to, cost increases in raw materials, supplier components, labor, utilities, freight, logistics, wages and benefits, regulatory compliance, or any other event beyond Company's control. If shipment is delayed due to Customer's actions, Company may also charge Customer with storage fees. If a release is not received within 6 months following order acceptance, Company reserves the right to cancel any order. Company shall be entitled to equitable adjustments in the contract price to reflect any cost increases as set forth above and will provide notice to Customer prior to the date for which the increased price is to be in effect for the applicable customer contract. In no event will prices be decreased. The price of Equipment does not include any present or future foreign, federal, state, or local property, license, privilege, sales, use, excise, value added, gross receipts or other like taxes or assessments. Such amounts will be itemized separately to Customer, who will make prompt payment to Company. Company will accept valid exemption documentation for such taxes and assessments from Customer, if applicable. All prices include packaging in accordance with Company's standard procedures. Charges for special packaging, crating or packing are the responsibility of Customer.

5. Delivery and Delays. Delivery dates are approximate and not guaranteed. Company will use commercially reasonable efforts to deliver the Equipment on or before the estimated delivery date, will notify Customer if the estimated delivery dates cannot be honored, and will deliver the Equipment and services as soon as practicable thereafter. In no event will Company be liable for any damages or expenses caused by delays in delivery.

6. Performance. Company shall be obligated to furnish only the Equipment described in the Proposal and in submittal data (if such data is issued in connection with the order). Company may rely on the acceptance of the Proposal and submittal data as acceptance of the suitability of the Equipment for the particular project or location. Unless specifically stated in the Proposal, compliance with any local building codes or other laws or regulations relating to specifications or the location, use or operation of the Equipment is the sole responsibility of Customer. If Equipment is tendered that does not fully comply with the provisions of this Agreement and Equipment is rejected by Customer, Company will have the right to cure within a reasonable time after notice thereof by substituting a conforming tender whether or not the time for performance has passed.

7. Force Majeure. Company's duty to perform under this Agreement and the Equipment prices are contingent upon the non-occurrence of an Event of Force Majeure. If the Company shall be unable to carry out any material obligation under this Agreement due to an Event of Force Majeure, this Agreement shall at Company's election (i) remain in effect but Company's obligations shall be suspended until the uncontrollable event terminates or (ii) be terminated upon 10 days' notice to Customer, in which event Customer shall pay Company for all parts of the Work furnished to the date of termination. An "Event of Force Majeure" shall mean any cause or event beyond the control of Company. Without limiting the foregoing, "Event of Force Majeure" includes: acts of God; acts of terrorism, war or the public enemy; flood; earthquake; tornado; storm; fire; civil disobedience; pandemic insurrections; riots; labor/labour disputes; labor/labour or material shortages; sabotage; restraint by court order or public authority (whether valid or invalid); and action or non-action by or inability to obtain or keep in force the necessary governmental authorizations, permits, licenses, certificates or approvals if not caused by Company; and the requirements of any applicable government in any manner that diverts either the material or the finished product to the direct or indirect benefit of the government.

8. Limited Warranty. Company warrants the Equipment manufactured by Company for a period of the lesser of 12 months from initial start-up or 18 months from date of shipment, whichever is less, against failure due to defects in material and manufacture and that it has the capacities and ratings set forth in Company's catalogs and bulletins ("Warranty"). **Equipment manufactured by Company that includes required start-up and sold in North America will not be warranted by Company unless Company performs the Equipment startup.** Exclusions from this Warranty include damage or failure arising from: wear and tear; corrosion, erosion, deterioration; modifications made by others to the Equipment; repairs or alterations by a party other than Company that adversely affects the stability or reliability of the Equipment; vandalism; neglect; accident; adverse weather or environmental conditions; abuse or improper use; improper installation; commissioning by a party other than Company; unusual physical or electrical or mechanical stress; operation with any accessory, equipment or part not specifically approved by Company; refrigerant not supplied by Company; and/or lack of proper maintenance as recommended by Company. Company shall not be obligated to pay for the cost of lost refrigerant or lost product. Company's obligations and liabilities under this Warranty are limited to furnishing replacement equipment or parts, at its option, FCA (Incoterms 2000) factory or warehouse (f.o.b. factory or warehouse for US domestic purposes) at Company-designated shipping point, freight-allowed to Company's warranty agent's stock location, for all non-conforming Company-manufactured Equipment (which have been returned by Customer to Company). Returns must have prior written approval by Company and are subject to restocking charge where applicable. Equipment, material and/or parts that are not manufactured by Company ("Third-Party Product(s)") are not warranted by Company and have such warranties as may be extended by the respective manufacturer. **CUSTOMER UNDERSTANDS THAT COMPANY IS NOT THE MANUFACTURER OF ANY THIRD-PARTY PRODUCT(S) AND ANY WARRANTIES, CLAIMS, STATEMENTS, REPRESENTATIONS, OR SPECIFICATIONS ARE THOSE OF THE THIRD-PARTY MANUFACTURER, NOT COMPANY AND CUSTOMER IS NOT RELYING ON ANY WARRANTIES, CLAIMS, STATEMENTS, REPRESENTATIONS, OR SPECIFICATIONS REGARDING THE THIRD-PARTY PRODUCT THAT MAY BE PROVIDED BY COMPANY OR ITS AFFILIATES, WHETHER ORAL OR WRITTEN. COMPANY MAKES NO REPRESENTATION OR WARRANTY OF ANY KIND, INCLUDING WARRANTY OF MERCHANTABILITY OR FITNESS FOR PARTICULAR PURPOSE. ADDITIONALLY, COMPANY MAKES NO REPRESENTATION OR WARRANTY OF ANY KIND REGARDING PREVENTING, ELIMINATING, REDUCING OR INHIBITING ANY MOLD, FUNGUS, BACTERIA, VIRUS, MICROBIAL GROWTH, OR ANY OTHER CONTAMINANTS (INCLUDING COVID-19 OR ANY SIMILAR VIRUS)**

(COLLECTIVELY, "CONTAMINANTS"), WHETHER INVOLVING OR IN CONNECTION WITH EQUIPMENT, ANY COMPONENT THEREOF, SERVICES OR OTHERWISE. IN NO EVENT SHALL COMPANY HAVE ANY LIABILITY FOR THE PREVENTION, ELIMINATION, REDUCTION OR INHIBITION OF THE GROWTH OR SPREAD OF SUCH CONTAMINANTS INVOLVING OR IN CONNECTION WITH ANY EQUIPMENT, THIRD-PARTY PRODUCT, OR ANY COMPONENT THEREOF, SERVICES OR OTHERWISE AND CUSTOMER HEREBY SPECIFICALLY ACKNOWLEDGES AND AGREES THERETO. No warranty liability whatsoever shall attach to Company until Customer's complete order has been paid for in full and Company's liability under this Warranty shall be limited to the purchase price of the Equipment shown to be defective. Additional warranty protection is available on an extra-cost basis and must be in writing and agreed to by an authorized signatory of the Company. EXCEPT FOR COMPANY'S WARRANTY EXPRESSLY SET FORTH HEREIN, COMPANY DOES NOT MAKE, AND HEREBY EXPRESSLY DISCLAIMS, ANY WARRANTIES, EXPRESS OR IMPLIED CONCERNING ITS PRODUCTS, EQUIPMENT OR SERVICES, INCLUDING, WITHOUT LIMITATION, ANY WARRANTY OF DESIGN, MERCHANTABILITY OR OF FITNESS FOR A PARTICULAR PURPOSE, OR OTHERS THAT ARE ALLEGED TO ARISE FROM COURSE OF DEALING OR TRADE.

9. Indemnity. To the fullest extent permitted by law, Company and Customer shall indemnify, defend and hold harmless each other from any and all claims, actions, costs, expenses, damages and liabilities, including reasonable attorneys' fees, resulting from death or bodily injury or damage to real or personal property, to the extent caused by the negligence or misconduct of their respective employees or other authorized agents in connection with their activities within the scope of this Agreement. Neither party shall indemnify the other against claims, damages, expenses or liabilities to the extent attributable to the acts or omissions of the other party. If the parties are both at fault, the obligation to indemnify shall be proportional to their relative fault. The duty to indemnify will continue in full force and effect, notwithstanding the expiration or early termination hereof, with respect to any claims based on facts or conditions that occurred prior to expiration or termination.

10. Insurance. Upon request, Company will furnish evidence of its standard insurance coverage. If Customer has requested to be named as an additional insured under Company's insurance policy, Company will do so but only subject to Company's manuscript additional insured endorsement under its primary Commercial General Liability policies. In no event does Company waive any rights of subrogation.

11. Customer Breach. Each of the following events or conditions shall constitute a breach by Customer and shall give Company the right, without an election of remedies, to terminate this Agreement, require payment prior to shipping, or suspend performance by delivery of written notice: (1) Any failure by Customer to pay amounts when due; (2) any general assignment by Customer for the benefit of its creditors, or if Customer becomes bankrupt or insolvent or takes the benefit of any statute for bankrupt or insolvent debtors, or makes or proposes to make any proposal or arrangement with creditors, or if any steps are taken for the winding up or other termination of Customer or the liquidation of its assets, or if a trustee, receiver, or similar person is appointed over any of the assets or interests of Customer; (3) Any representation or warranty furnished by Customer in connection with this Agreement is false or misleading in any material respect when made; or (4) Any failure by Customer to perform or comply with any material provision of this Agreement. Customer shall be liable to the Company for all Equipment furnished and all damages sustained by Company (including lost profit and overhead).

12. Limitation of Liability. NOTWITHSTANDING ANYTHING TO THE CONTRARY, IN NO EVENT SHALL COMPANY BE LIABLE FOR ANY SPECIAL, INCIDENTAL, INDIRECT CONSEQUENTIAL, PUNITIVE, EXEMPLARY DAMAGES (INCLUDING WITHOUT LIMITATION REFRIGERANT LOSS, BUSINESS INTERRUPTION, LOST DATA, LOST REVENUE, LOST PROFITS), OR CONTAMINANTS LIABILITIES, EVEN IF A PARTY HAS BEEN ADVISED OF SUCH POSSIBLE DAMAGES OR IF SAME WERE REASONABLY FORESEEABLE AND REGARDLESS OF WHETHER THE CAUSE OF ACTION IS FRAMED IN CONTRACT, NEGLIGENCE, ANY OTHER TORT, WARRANTY, STRICT LIABILITY, OR PRODUCT LIABILITY. In no event will Company's liability in connection with the provision of products or services or otherwise under this Agreement exceed the entire amount paid to Company by Customer under this Agreement.

13. CONTAMINANTS LIABILITY

The transmission of COVID-19 may occur in a variety of ways and circumstances, many of the aspects of which are currently not known. HVAC systems, products, services and other offerings have not been tested for their effectiveness in reducing the spread of COVID-19, including through the air in closed environments. IN NO EVENT WILL COMPANY BE LIABLE UNDER THIS AGREEMENT OR OTHERWISE FOR ANY BODILY INJURY (INCLUDING DEATH), DAMAGE TO PROPERTY, OR ANY OTHER LIABILITIES, DAMAGES OR COSTS RELATED TO CONTAMINANTS (INCLUDING THE SPREAD, TRANSMISSION, MITIGATION, ELIMINATION, OR CONTAMINATION THEREOF) (COLLECTIVELY, "CONTAMINANTS LIABILITIES") AND CUSTOMER HEREBY EXPRESSLY RELEASES COMPANY FROM ANY SUCH CONTAMINANTS LIABILITIES.

14. Nuclear Liability. In the event that the Equipment sold hereunder is to be used in a nuclear facility, Customer will, prior to such use, arrange for insurance or governmental indemnity protecting Company against all liability and hereby releases and agrees to indemnify Company and its suppliers for any nuclear damage, including loss of use, in any manner arising out of a nuclear incident, whether alleged to be due, in whole or in part to the negligence or otherwise of Company or its suppliers.

15. Intellectual Property; Patent Indemnity. Company retains all ownership, license and other rights to all patents, trademarks, copyrights, trade secrets and other intellectual property rights related to the Equipment, and, except for the right to use the Equipment sold, Customer obtains no rights to use any such intellectual property. Company agrees to defend any suit or proceeding brought against Customer so far as such suit or proceeding is solely based upon a claim that the use of the Equipment provided by Company constitutes infringement of any patent of the United States of America, provided Company is promptly notified in writing and given authority, information and assistance for defense of same. Company will, at its option, procure for Customer the right to continue to use said Equipment, or modify it so that it becomes non-infringing, or replace same with non-infringing Equipment, or to remove said Equipment and to refund the purchase price. The foregoing will not be construed to include any Agreement by Company to accept any liability whatsoever in respect to patents for inventions including more than the Equipment furnished hereunder, or in respect of patents for methods and processes to be carried out with the aid of said Equipment. The provision of Equipment by Company does not convey any license, by implication, estoppel, or otherwise, under patent claims covering combinations of said Equipment with other devices or elements. The foregoing states the entire liability of Company with regard to patent infringement. Notwithstanding the provisions of this paragraph, Customer will hold Company harmless against any expense or loss resulting from infringement of patents or trademarks arising from compliance with Customer's designs or specifications or instructions.

16. Cancellation. Equipment is specially manufactured in response to orders. An order placed with and accepted by Company cannot be delayed, canceled, suspended, or extended except with Company's written consent and upon written terms accepted by Company that will reimburse Company for and indemnify Company against loss and provide Company with a reasonable profit for its materials, time, labor, services, use of facilities and otherwise. Customer will be obligated to accept any Equipment shipped, tendered for delivery or delivered by Company pursuant to the order prior to any agreed delay, cancellation, suspension or extension of the order. Any attempt by Customer to unilaterally revoke, delay or suspend acceptance for any reason whatever after it has agreed to delivery of or accepted any shipment shall constitute a breach of this Agreement. For purposes of this paragraph, acceptance occurs by any waiver of inspection, use or possession of Equipment, payment of the invoice, or any indication of exclusive control exercised by Customer.

17. Invoicing and Payment. Unless otherwise agreed to in writing by Company, equipment shall be invoiced to Customer upon tender of delivery thereof to the carrier. Customer shall pay Company's invoices within net 30 days of shipment date. Company reserves the right to add to any account outstanding for more than 30 days a service charge equal to the lesser of the maximum allowable legal interest rate or 1.5% of the principal amount due at the end of each month. Customer shall pay all costs (including attorneys' fees) incurred by Company in attempting to collect amounts due and otherwise enforcing these terms and conditions. If requested, Company will provide appropriate lien waivers upon receipt of payment. Company may at any time decline to ship, make delivery or perform work except upon receipt of cash payment, letter of credit, or security, or upon other terms

and conditions satisfactory to Company. Customer agrees that, unless Customer makes payment in advance, Company will have a purchase money security interest in all Equipment to secure payment in full of all amounts due Company and its order for the Equipment, together with these terms and conditions, form a security agreement (as defined by the UCC in the United States and as defined in the Personal Property Security Act in Canada). Customer shall keep the Equipment free of all taxes and encumbrances, shall not remove the Equipment from its original installation point and shall not assign or transfer any interest in the Equipment until all payments due Company have been made. The purchase money security interest granted herein attaches upon Company's acceptance of Customer's order and on receipt of the Equipment described in the accepted Proposal but prior to its installation. The parties have no agreement to postpone the time for attachment unless specifically noted in writing on the accepted order. Customer will have no rights of set off against any amounts, which become payable to Company under this Agreement or otherwise.

18. Claims. Company will consider claims for concealed shortages in shipments or rejections due to failure to conform to an order only if such claims or rejections are made in writing within 15 days of delivery and are accompanied by the packing list and, if applicable, the reasons in detail why the Equipment does not conform to Customer's order. Upon receiving authorization and shipping instructions from authorized personnel of Company, Customer may return rejected Equipment, transportation charges prepaid, for replacement. Company may charge Customer any costs resulting from the testing, handling, and disposition of any Equipment returned by Customer which are not found by Company to be nonconforming. All Equipment damaged during shipment and all claims relating thereto must be made with the freight carrier in accordance with such carrier's policies and procedures. Claims for Equipment damaged during shipment are not covered under the warranty provision stated herein.

19. Export Laws. The obligation of Company to supply Equipment under this Agreement is subject to the ability of Company to supply such items consistent with applicable laws and regulations of the United States and other governments. Company reserves the right to refuse to enter into or perform any order, and to cancel any order, under this Agreement if Company in its sole discretion determines that performance of the transaction to which such order relates would violate any such applicable law or regulation. Customer will pay all handling and other similar costs from Company's factories including the costs of freight, insurance, export clearances, import duties and taxes. Customer will be "exporter of record" with respect to any export from the United States of America and will perform all compliance and logistics functions in connection therewith and will also comply with all applicable laws, rules and regulations. Customer understands that Company and/or the Equipment are subject to laws and regulations of the United States of America which may require licensing or authorization for and/or prohibit export, re-export or diversion of Company's Equipment to certain countries, and agrees it will not knowingly assist or participate in any such diversion or other violation of applicable United States of America laws and regulations. Customer agrees to hold harmless and indemnify Company for any damages resulting to Customer or Company from a breach of this paragraph by Customer.

20. General. Except as provided below, to the maximum extent provided by law, this Agreement is made and shall be interpreted and enforced in accordance with the laws of the state of New York for Equipment shipped to a U.S. location and the laws of the province to which Equipment is shipped within Canada, without regard to its conflict of law principles that might otherwise call for the application of a different state's or province's law, and not including the United Nations Convention on Contracts for the International Sale of Goods. Any action or suit arising out of or related to this Agreement must be commenced within one year after the cause of action has accrued. To the extent the Equipment is being used at a site owned and/or operated by any agency of the Federal Government, determination of any substantive issue of law shall be according to the Federal common law of Government contracts as enunciated and applied by Federal judicial bodies and boards of contract appeals of the Federal Government. This Agreement contains all of the agreements, representations and understandings of the parties and supersedes all previous understandings, commitments or agreements, oral or written, related to the subject matter hereof. This Agreement may not be amended, modified or terminated except by a writing signed by the parties hereto. No documents shall be incorporated herein by reference except to the extent Company is a signatory thereon. If any term or condition of this Agreement is invalid, illegal or incapable of being enforced by any rule of law, all other terms and conditions of this Agreement will nevertheless remain in full force and effect as long as the economic or legal substance of the transaction contemplated hereby is not affected in a manner adverse to any party hereto. Customer may not assign, transfer, or convey this Agreement, or any part hereof, or its right, title or interest herein, without the written consent of the Company. Subject to the foregoing, this Agreement shall be binding upon and inure to the benefit of Customer's permitted successors and assigns. This Agreement may be executed in several counterparts, each of which when executed shall be deemed to be an original, but all together shall constitute but one and the same Agreement. A fully executed facsimile copy hereof or the several counterparts shall suffice as an original.

21. Equal Employment Opportunity/Affirmative Action Clause. Company is a federal contractor that complies fully with Executive Order 11246, as amended, and the applicable regulations contained in 41 C.F.R. Parts 60-1 through 60-60, 29 U.S.C. Section 793 and the applicable regulations contained in 41 C.F.R. Part 60-741; and 38 U.S.C. Section 4212 and the applicable regulations contained in 41 C.F.R. Part 60-250 Executive Order 13496 and Section 29 CFR 471, appendix A to subpart A, regarding the notice of employee rights in the United States and with Canadian Charter of Rights and Freedoms Schedule B to the Canada Act 1982 (U.K.) 1982, c. 11 and applicable Provincial Human Rights Codes and employment law in Canada.

22. U.S. Government Work.

The following provision applies only to direct sales by Company to the US Government. The Parties acknowledge that Equipment ordered and delivered under this Agreement are Commercial Items as defined under Part 12 of the Federal Acquisition Regulation (FAR). In particular, Company agrees to be bound only by those Federal contracting clauses that apply to "commercial" suppliers and that are contained in FAR 52.212-5(e)(1).

The following provision applies only to indirect sales by Company to the US Government. As a Commercial Item Subcontractor, Company accepts only the following mandatory flow down provisions: 52.219-8; 52.222-26; 52.222-35; 52.222-36; 52.222-39; 52.247-64. If the sale of the Equipment is in connection with a U.S. Government contract, Customer certifies that it has provided and will provide current, accurate, and complete information, representations and certifications to all government officials, including but not limited to the contracting officer and officials of the Small Business Administration, on all matters related to the prime contract, including but not limited to all aspects of its ownership, eligibility, and performance. Anything herein notwithstanding, Company will have no obligations to Customer unless and until Customer provides Company with a true, correct and complete executed copy of the prime contract. Upon request, Customer will provide copies to Company of all requested written communications with any government official related to the prime contract prior to or concurrent with the execution thereof, including but not limited to any communications related to Customer's ownership, eligibility or performance of the prime contract. Customer will obtain written authorization and approval from Company prior to providing any government official any information about Company's performance of the work that is the subject of the Proposal or this Agreement, other than the Proposal or this Agreement.

23. Limited Waiver of Sovereign Immunity. If Customer is an Indian tribe (in the U.S.) or a First Nation or Band Council (in Canada), Customer, whether acting in its capacity as a government, governmental entity, a duly organized corporate entity or otherwise, for itself and for its agents, successors, and assigns: (1) hereby provides this limited waiver of its sovereign immunity as to any damages, claims, lawsuit, or cause of action (herein "Action") brought against Customer by Company and arising or alleged to arise out of the furnishing by Company of any product or service under this Agreement, whether such Action is based in contract, tort, strict liability, civil liability or any other legal theory; (2) agrees that jurisdiction and venue for any such Action shall be proper and valid (a) if Customer is in the U.S., in any state or United States court located in the state in which Company is performing this Agreement or (b) if Customer is in Canada, in the superior court of the province or territory in which the work was performed; (3) expressly consents to such Action, and waives any objection to jurisdiction or venue; (4) waives any requirement of exhaustion of tribal court or administrative remedies for any Action arising out of or related to this Agreement; and (5) expressly acknowledges and agrees that Company is not subject to the jurisdiction of Customer's tribal court or any similar tribal forum, that Customer will not bring any action against Company in tribal court, and that Customer will not avail itself of any ruling or direction of the tribal court permitting or directing it to suspend its payment or other obligations under this Agreement. The individual signing on behalf of Customer warrants and represents that such individual is duly authorized to

provide this waiver and enter into this Agreement and that this Agreement constitutes the valid and legally binding obligation of Customer, enforceable in accordance with its terms.

1-26.130-4 (1221b)
Supersedes 1-26.130-4(1221)



Submittal

Prepared For:
Kendall County

Date: May 25, 2022

Job Name:
Kendall County Forest Preserve Ken Pickerill House

Trane U.S. Inc. is pleased to provide the following submittal for your review and approval.

Product Summary

Qty Product

2 1.5-5 Ton Pkgd. Heat Pump Rooftop R-410A (13WC)

Mo Alikhan
Trane U.S. Inc.
7100 South Madison
Willowbrook, IL 60527
Office Phone: (630) 734-3200

The attached information describes the equipment we propose to furnish for this project, and is submitted for your approval.

Product performance and submittal data is valid for a period of 6 months from the date of submittal generation. If six months or more has elapsed between submittal generation and equipment release, the product performance and submittal data will need to be verified. It is the customer's responsibility to obtain such verification.

Table of Contents

Product Summary	1
1.5-5 Ton Pkgd. Heat Pump Rooftop R-410A (13WC) (Items A1, A2).....	3
Tag Data	3
Product Data	3
Mechanical Specifications.....	4
Dimensional Drawings	6
Weight, Clearance & Rigging.....	10
Accessory.....	12
Field Installed Options - Part/Order Number Summary	13
1.5-5 Ton Pkgd. Heat Pump Rooftop R-410A	13

Tag Data - 1.5-5 Ton Pkgd. Heat Pump Rooftop R-410A (13WC) (Qty: 2)

Item	Tag(s)	Qty	Description	Model Number
A1	RTU-1	1	1.5-5 Ton Pkgd. Heat Pump Rooftop R-410A	4WCY5036*1000
A2	RTU-2	1	1.5-5 Ton Pkgd. Heat Pump Rooftop R-410A	4WCY5048*1000

Product Data - 1.5-5 Ton Pkgd. Heat Pump Rooftop R-410A (13WC)

All Units

- R-410A convertible heat pump 15 SEER
- 208-230/1/60
- 1-2" Filter frame (Field Installed)
- Hinged Filter Access Door (Field Installed)
- 2 heat/1 coll digital non-programmable (Field Installed)
- Evaporator defrost control (Field Installed)
- Low ambient control kit (Field Installed)
- Lifting lug kit (Field Installed)
- 1st yr Labor warranty whole unit

Item: A1 Qty: 1 Tag(s): RTU-1

- 3 Tons, 14 /16 SEER
- 11.27/15.0kw 208/240/1 (Field Installed)

Item: A2 Qty: 1 Tag(s): RTU-2

- 4Tons, 14 /16 SEER
- 15.0/20.0kw 208/240/1 (Field Installed)

Mechanical Specifications - 1.5-5 Ton Pkgd. Heat Pump Rooftop R-410A**Item: A1, A2 Qty: 2 Tag(s): RTU-1, RTU-2****Standard Indoor Thermostats**

Two stage heating/cooling or one stage heating/cooling thermostats shall be available in either manual or automatic changeover.

Electric Heaters

Each heater assembly shall include power supply fusing if over 48 amps, automatic resetting limit switches and heat limiter for thermal protection. Heaters shall be provided with polarized plugs for quick connection to unit low voltage wiring. Electric heat modules shall be UL listed.

4WCY5 - General

The units shall be horizontal airflow as shipped and convertible to downflow. All units shall be factory assembled, piped, internally wired and fully charged with refrigerant. Units shall be certified to UL Standard 1995. All units shall be factory run tested to check cooling operation, fan and blower rotation and control or TXV sequence. Units shall be designed to operate at ambient temperatures between 115.0 F and 55.0 F in cooling as manufactured. Cooling performance shall be rated in accordance with AHRI standards.

4WCY5 - Unit Casing

All components shall be mounted in a weather-resistant steel cabinet with an enamel finish. Access panels shall be provided for unit controls and indoor coil and fans. Indoor air section compartment shall be completely insulated with fireproof, permanent, odorless fiber material. Knockouts shall be provided for utility and control connections. Drain connections shall be provided to accommodate indoor water runoff.

4WCY5 - Compressor

The compressor shall be hermetically sealed, high efficiency scroll compressors. Internal overcurrent and over temperature protection, internal pressure relief shall be standard. Other features include centrifugal oil pump, low vibration and noise.

4WCY5 - Refrigeration System

All units shall have refrigerant control. Service pressure tap ports and a refrigerant line filter shall be standard.

4WCY5 - Evaporator Coil

Internally enhanced 3/8" OD seamless copper tubing mechanically bonded to aluminum fins, factory pressure and leak tested at 480 - 650 psig. All units have TXV to control refrigerant flow.

4WCY5 - Condenser Coil

The Spine Fin TM condenser coil shall be continuously wrapped, corrosion resistant all aluminum with minimum brazed joints. This coil is 3/8" OD seamless aluminum tubing glued to a continuous aluminum fin. Coils are lab tested to withstand 2000.0 lb of pressure per square inch. The outdoor coil provides low airflow resistance and efficient heat transfer. The coil is protected on all four sides by louvered panels.

4WCY5 - Indoor Air Fan

Constant Torque, forward-curved, centrifugal wheel in a Composite Vortica ® Blower housing. Motor shall have thermal overload protection and permanently lubricated motor bearings. Motor/blower assembly isolated from unit with rubber mounts.

4WCY5 - Outdoor Fan

One direct-drive, statically and dynamically balanced propeller fan shall be used in a draw-through vertical discharge configuration. Permanently lubricated weather proof motor shall have built-in thermal overload protection.

4WCY5 - System Controls

System controls include condenser fan, evaporator fan and compressor contactors. Accessories Roof

4WCY5 - Electric Heaters

Each heater assembly shall include power supply fusing if over 48 amps, automatic resetting limit switches and heat limiters for thermal protection. Heaters shall be provided with polarized plugs for quick connection to unit low voltage wiring. Electric heat modules shall be UL listed.

4WCY5 - Single Source Power Entry

This accessory when used with electric heat accessory shall allow single source power connection to unit and heater combination. Single source power entry kits shall have specific matching heater(s). Kit shall include high voltage terminal blocks, fuse blocks and fuses, cut-to-length interconnecting wiring, and junction box (if required) to provide power sources with fuse protection as required for both the unit and accessory heater. Kit components shall install within the heater cabinet in the heater access section. Single source branch power circuit shall be protected and wired in accordance with local codes.

Dimensional Drawings - 1.5-5 Ton Pkgd. Heat Pump Rooftop R-410A
Item: A1 Qty: 1 Tag(s): RTU-1

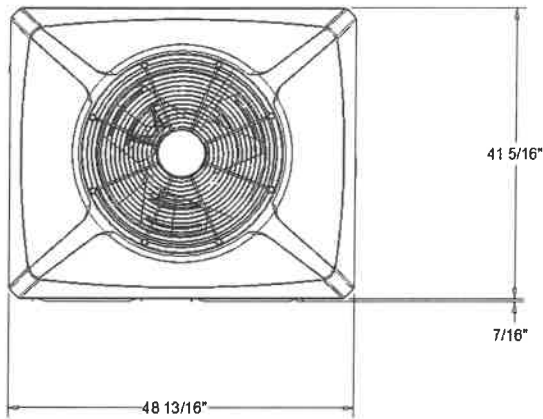

UNIT - TOP VIEW

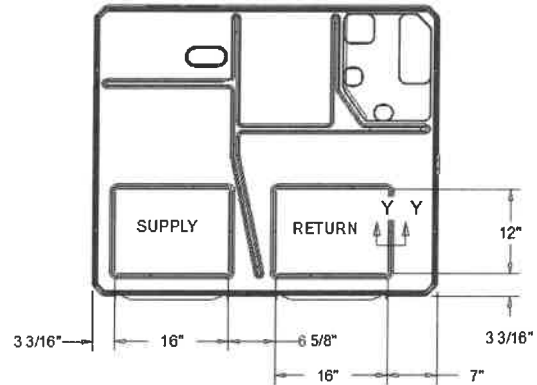

UNIT - BOTTOM PENETRATION VIEW

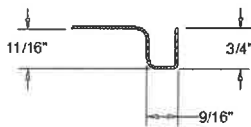

SECTION Y-Y
 TYPICAL (8) SIDES OF
 DOWNFLOW DUCT OPENINGS

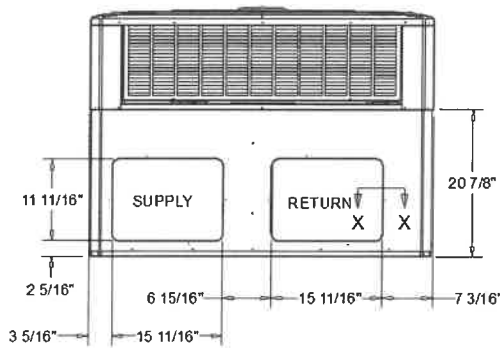

UNIT - BACK AND PENETRATION VIEW

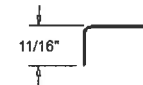

SECTION X-X
 TYPICAL (8) SIDES OF
 SIDEFLOW DUCT OPENINGS

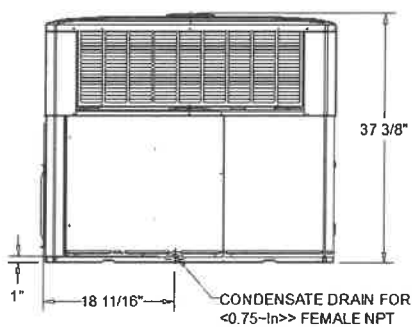

UNIT - LEFT SIDE VIEW

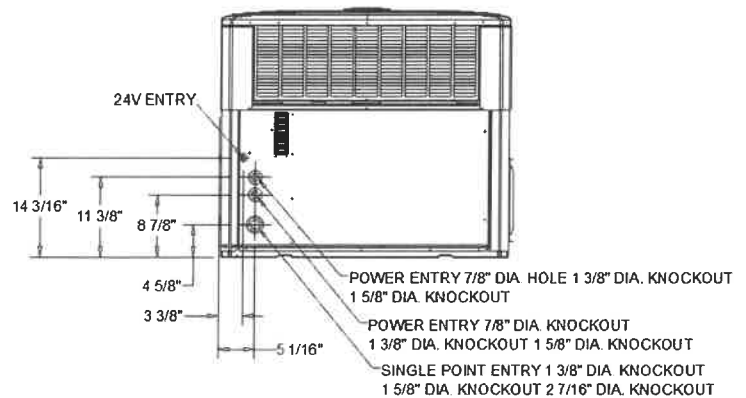

UNIT - RIGHT SIDE VIEW

Dimensional Drawings - 1.5-5 Ton Pkgd. Heat Pump Rooftop R-410A

Item: A1 Qty: 1 Tag(s): RTU-1

ELECTRICAL / GENERAL DATA

POWER CONNECTION Model: 4WCY5036A1 Voltage Range: 208-230/1.60 Min. Circuit Ampacity: 24.7 Max. Circuit Breaker: 40.0 Prot. Rtg. Recmd: 40.0 EER/SEER: - Noise Rating #: 12.00/15.00 69.4		COMPRESSOR Number: 1 Phase: 1 Rated Load Amps: 15.4 Locked Rotor Amps: 84.0	
OUTDOOR MOTOR Number: 1 Horsepower: 0.20 Phase: 1 Full Load Amps: 1.1 Locked Rotor Amps: 2.0	INDOOR MOTOR Number: 1 Horsepower: 0.5 Motor Speed (RPM): VARIABLE Phase: 1 Full Load Amps: 4.3 Locked Rotor Amps:	REFRIGERANT Type: R-410A Factory Charge: 7.2 lb Circuit #1:	
HEATER Model: BAYHTRV115 Voltage: 208/240 Phase: 1 Heater Capacity (Kw): 11.27/15.0 Heater (Btu): 38,500/51,200 # of Stages: 2 Stage # 1: 7.5/10.0 Stage # 2: 3.75/5.0 MCA: 68.0/78.0 MBS: 70.0/80.0		SINGLE CIRCUIT POWER AMPACITY AND OVER CURRENT PROTECTION Single Power Entry Kit Minimum Circuit Ampacity Maximum Over-Current Device 1. Single Circuit Power fuses are supplied if required for unit and / or heater 2. Wiring requirements if unit and electric heaters are operated from a single circuit using a single power entry kit.	

NOTES:

UNIT ONLY

1. Rated in accordance with A.H.R.I. Standard 210/240.
2. Rated in accordance with D.O.E. test procedure.
3. Rated in accordance with A.H.R.I. Standard 270.

ELECTRIC HEATER ACCESSORY ONLY

4. Any power supply and circuits must be wired and protected in accordance with local electrical codes.
5. The MCA values listed are for electric heater only.
6. The MCA values listed are for electric heater only.
7. Field wire must be rated at least 75 C.
8. The HACR circuit breaker is for U.S.A. installations only.
9. For Canada installations reference only.

Dimensional Drawings - 1.5-5 Ton Pkgd. Heat Pump Rooftop R-410A
 Item: A2 Qty: 1 Tag(s): RTU-2

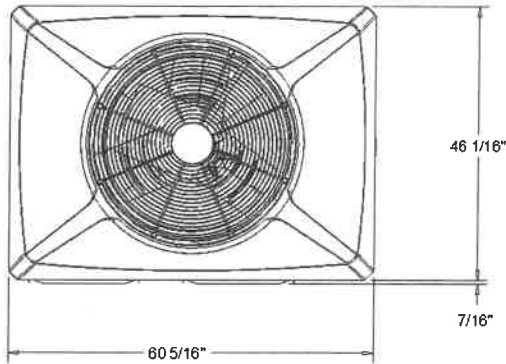

UNIT - TOP VIEW

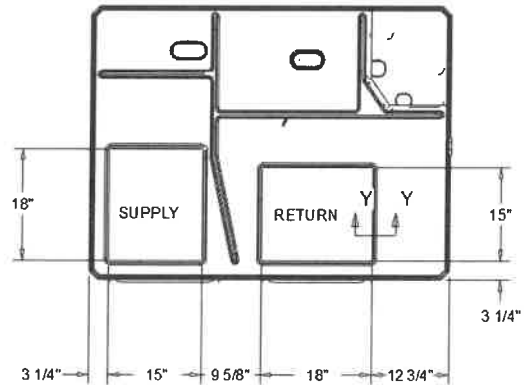

UNIT - BOTTOM PENETRATION VIEW

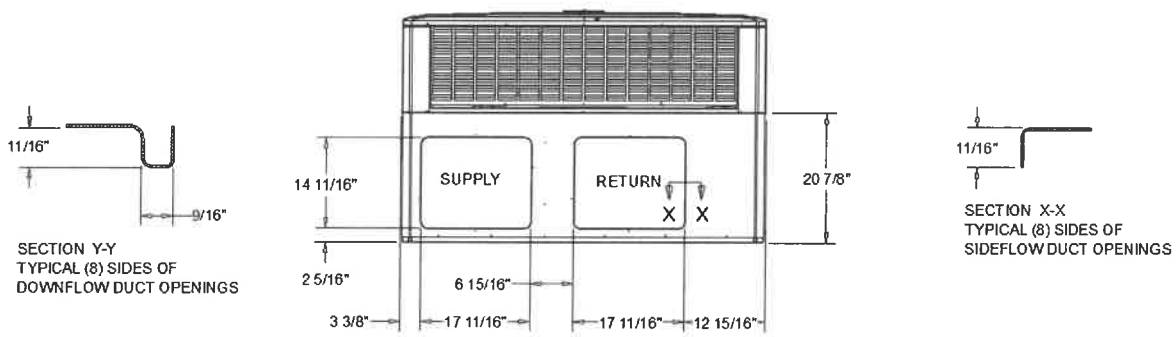

UNIT - BACK AND PENETRATION VIEW

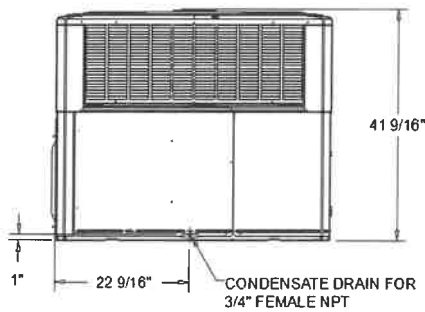

UNIT - LEFT SIDE VIEW

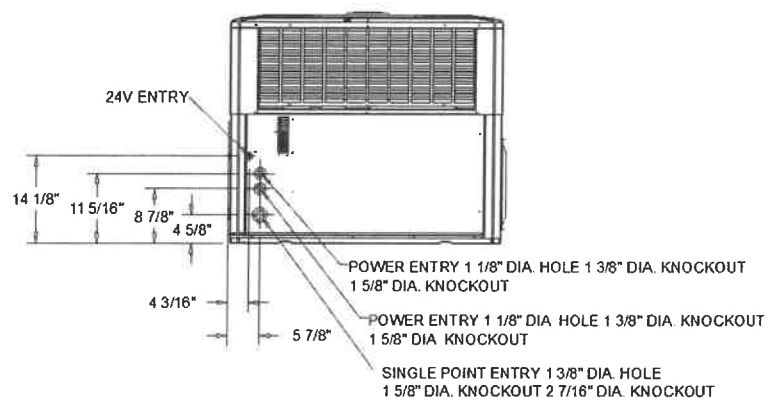

UNIT - RIGHT SIDE VIEW

Dimensional Drawings - 1.5-5 Ton Pkgd. Heat Pump Rooftop R-410A
Item: A2 Qty: 1 Tag(s): RTU-2

ELECTRICAL / GENERAL DATA

POWER CONNECTION Model: Voltage Range: Min. Circuit Ampacity: Max. Circuit Breaker: Prot. Rtg. Recmd: EER/SEER Noise Rating # :		COMPRESSOR Number: 1 Phase: 1 Rated Load Amps: 21.2 Locked Rotor Amps: 104.0	
OUTDOOR MOTOR Number: 1 Horsepower: 0.16 Phase: 1 Full Load Amps: 0.9 Locked Rotor Amps: 1.65	INDOOR MOTOR Number: 1 Horsepower: 0.75 Motor Speed (RPM): VARIABLE Phase: 1 Full Load Amps: 6.8 Locked Rotor Amps:	REFRIGERANT Type: R-410A Factory Charge: 9.6 lb Circuit #1:	
HEATER Model: BAYHTRV120 Voltage: 208/240 Phase: 1 Heater Capacity (Kw): 15.0/20.0 Heater (Btu): 51200/68300 # of Stages: 2 Stage # 1: 7.5/10.0 Stage # 2: 7.5/10.0 MCA: 90.0/104.0 MBS: 90.0/110.0		SINGLE CIRCUIT POWER AMPACITY AND OVER CURRENT PROTECTION Single Power Entry Kit Minimum Circuit Ampacity Maximum Over-Current Device 1. Single Circuit Power fuses are supplied if required for unit and / or heater 2. Wiring requirements if unit and electric heaters are operated from a single circuit using a single power entry kit.	

NOTES:

UNIT ONLY

1. Rated in accordance with A.H.R.I. Standard 210/240.
2. Rated in accordance with D.O.E. test procedure.
3. Rated in accordance with A.H.R.I. Standard 270.

ELECTRIC HEATER ACCESSORY ONLY

4. Any power supply and circuits must be wired and protected in accordance with local electrical codes.
5. The MCA values listed are for electric heater only.
6. The MCA values listed are for electric heater only.
7. Field wire must be rated at least 75 C.
8. The HACR circuit breaker is for U.S.A. installations only.
9. For Canada installations reference only.

Weight, Clearance & Rigging - 1.5-5 Ton Pkgd. Heat Pump Rooftop R-410A
Item: A1 Qty: 1 Tag(s): RTU-1

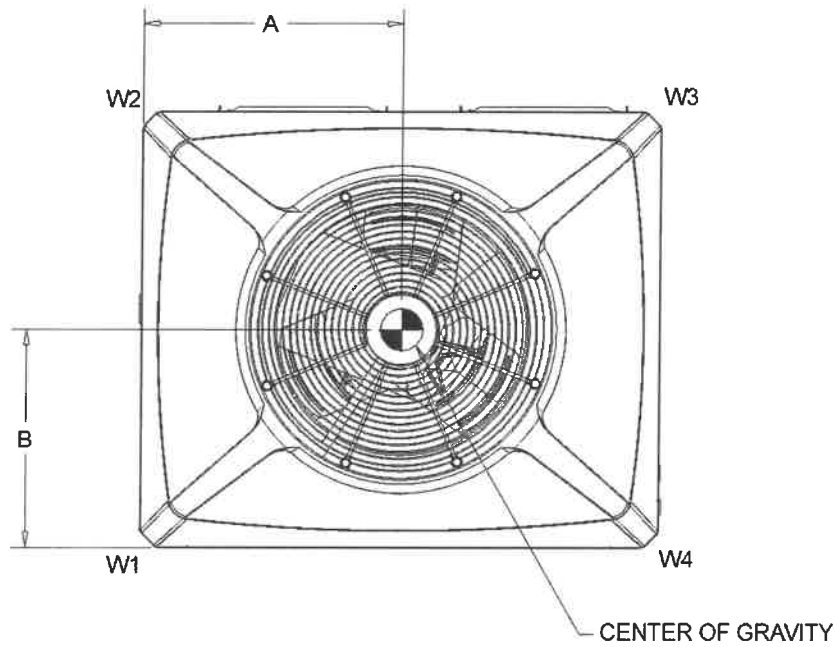

UNIT WEIGHT		CORNER WEIGHT				CENTER OF GRAVITY	
SHIPPING	NET	W1	W2	W3	W4	A	B
468.0 lb	372.0 lb	134.0 lb	84.0 lb	80.0 lb	94.0 lb	15 13/16"	20"
CLEARANCE TO COMBUSTIBLE MATERIAL		RECOMMENDED SERVICE CLEARANCE					
BOTTOM	0	UNIT		WITH O.A. DAMPER/ECON.	WITH 2 POS. DAMPER		
BACK SIDE	1"	BACK SIDE	12"		30"		
LEFT SIDE	6"	LEFT SIDE	36"	42"			
RIGHT SIDE	6"	RIGHT SIDE	24"				
FRONT SIDE	12"	FRONT SIDE	42"				
TOP	36"						

LIFTING LUG KITS
 FOUR REUSABLE LUGS IN EACH KIT ALLOW UNITS TO BE EASILY LIFTED TO ROOFTOP INSTALLATIONS.
 THESE LUGS SNAP (NO SCREWS REQUIRED) INTO SLOTS IN THE UNIT DRIP LIP CHANNEL.

Weight, Clearance & Rigging - 1.5-5 Ton Pkgd. Heat Pump Rooftop R-410A
Item: A2 Qty: 1 Tag(s): RTU-2

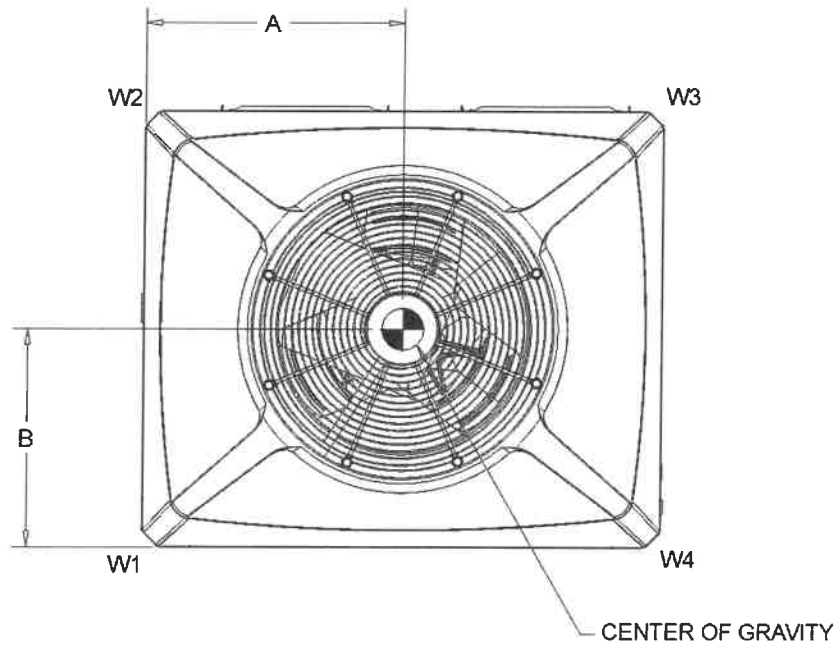

UNIT WEIGHT		CORNER WEIGHT				CENTER OF GRAVITY	
SHIPPING	NET	W1	W2	W3	W4	A	B
623.0 lb	495.0 lb	152.0 lb	90.0 lb	88.0 lb	115.0 lb	16 5/16"	25"
CLEARANCE TO COMBUSTIBLE MATERIAL		RECOMMENDED SERVICE CLEARANCE					
BOTTOM	0	UNIT		WITH O.A. DAMPER/ECON.	WITH 2 POS. DAMPER		
BACK SIDE	1"	BACK SIDE	12"		30"		
LEFT SIDE	6"	LEFT SIDE	36"	42"			
RIGHT SIDE	6"	RIGHT SIDE	24"				
FRONT SIDE	12"	FRONT SIDE	42"				
TOP	36"						

LIFTING LUG KITS
 FOUR REUSABLE LUGS IN EACH KIT ALLOW UNITS TO BE EASILY LIFTED TO ROOFTOP INSTALLATIONS.
 THESE LUGS SNAP (NO SCREWS REQUIRED) INTO SLOTS IN THE UNIT DRIP LIP CHANNEL.

Accessory - 1.5-5 Ton Pkgd. Heat Pump Rooftop R-410A
Item: A1, A2 Qty: 2 Tag(s): RTU-1, RTU-2

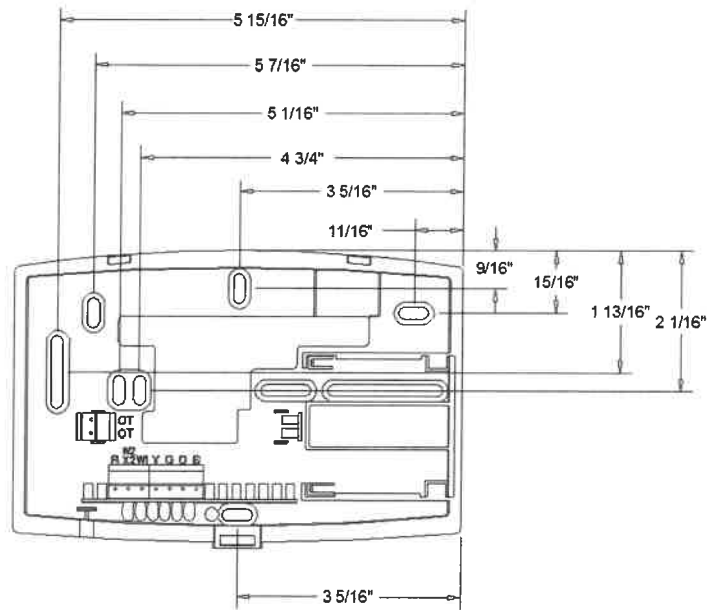

FRONT VIEW OF SUB BASE
(TERMINAL BLOCK AND DRAWER NOT SHOWN)

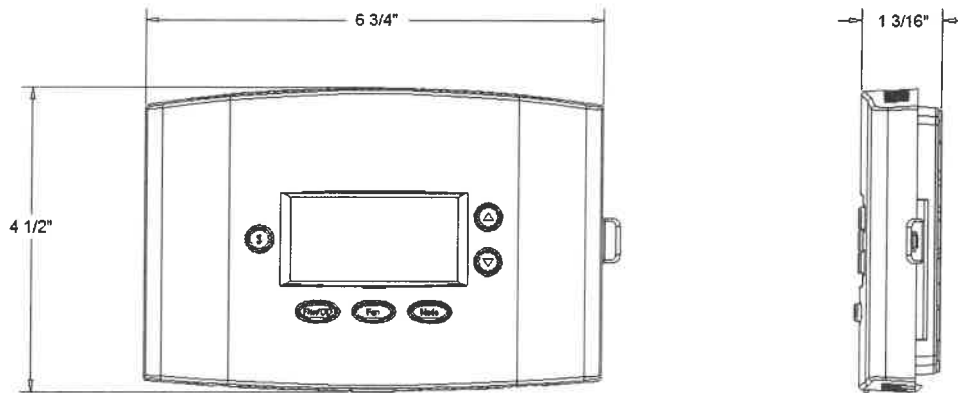

FRONT VIEW

THERMOSTAT - TCONT401A

Field Installed Options - Part/Order Number Summary

This is a report to help you locate field installed options that arrive at the jobsite. This report provides part or order numbers for each field installed option, and references it to a specific product tag. It is NOT intended as a bill of material for the job.

Product Family - 1.5-5 Ton Pkgd. Heat Pump Rooftop R-410A

Item	Tag(s)	Qty	Description	Model Number
A1	RTU-1	1	1.5-5 Ton Pkgd. Heat Pump Rooftop R-410A	4WCY5036*1000

Field Installed Option Description	Part/Ordering Number
11.27/15.0kw 208/240/1	BAYHTRV115F
1-2" Filter frame	BAYFLTR101C
Hinged Filter Access Door	BAYACCDOR1A
2 heat/1 coll digital non-programmable	TCONT401AN21MA
Evaporator defrost control	BAYLOAM011A
Low ambient control kit	BAYLOAM105A
Lifting lug kit	BAYLIFT002B

Item	Tag(s)	Qty	Description	Model Number
A2	RTU-2	1	1.5-5 Ton Pkgd. Heat Pump Rooftop R-410A	4WCY5048*1000

Field Installed Option Description	Part/Ordering Number
15.0/20.0kw 208/240/1	BAYHTRV120F
1-2" Filter frame	BAYFLTR201C
Hinged Filter Access Door	BAYACCDOR2A
2 heat/1 coll digital non-programmable	TCONT401AN21MA
Evaporator defrost control	BAYLOAM011A
Low ambient control kit	BAYLOAM105A
Lifting lug kit	BAYLIFT002B



HVAC Systems and Energy Services



Easier, simpler and quicker with cooperative purchasing

State of Illinois Contract
#22-510CPOGS-B-25977

Becoming a participant of the Illinois State Board of Education (ISBE) Education Purchasing Program (EPP) enables public agencies to drive efficiency, effectiveness and real savings with world-class government procurement resources and solutions. The entire portfolio of Trane equipment and services is available via a State of Illinois and ISBE approved purchasing program, saving time and money.

The ISBE EPP gives you greater purchasing power to unleash the potential of your buildings with Trane solutions. Trane is an industry leader in energy efficient, connected indoor comfort systems, providing full lifecycle support through a world-class services organization. Our mission is to collaborate with organizations to reduce the energy intensity of the world. Through innovative technology and unsurpassed expertise in buildings, we're helping organizations achieve real and enduring sustainability results.

Trane® Energy Services. Trane can help you manage both energy supply and demand. Our extensive portfolio of energy services can help you navigate energy purchasing strategies, energy sourcing, storage and consumption. We're experts in a wide range of distributed energy resources using renewable energy (cogeneration, photovoltaic, biomass, biogas and wind power) to lower operating costs, reduce environmental impact and gain energy independence and resiliency. Trane is an Energy Services Company (ESCO) accredited by NAESCO® and certified through the Canadian Federal Buildings initiative.

Elevate Your Purchasing Power

Cooperative purchasing can put your best building within reach. All agreements offered through the ISBE EPP are competitively solicited and awarded by a public agency/governmental entity (e.g. city, county, or school district) via a thorough Request for Proposal (RFP). By utilizing a cooperative purchasing program, public agencies can drive efficiency and effectiveness saving valuable time, resources, and money.

Solutions | The entire portfolio of Trane products and services is included in the contract.



HVAC Systems—Scalable system solutions for maintaining ideal temperature, humidity and CO₂



Energy Services—Managing your energy supply and demand to reduce cost, optimize performance and improve sustainability



Optimized Equipment—Ductless, DX, Unitary, Air Handling, Terminal, and Chilled Water Systems



Building Services—Reliable, preventative and proactive scheduled maintenance and repair by factory trained technicians



Building Automation Systems—Making precise control easier, mobile and data-rich



Rental Systems—Promptly provides temporary, scalable HVAC and power from standard applications to complex solutions



Intelligent Services™—Monitoring and analytics to optimize your building and minimize unexpected downtime



Parts & Supplies—High performance OEM and wholesale parts and supplies to install and keep your HVAC system running

Clean air technologies by Trane.



Want to know more? Email us at TraneStateContractIL@trane.com | Call us at (888) 770-6469 | Visit us at trane.com/chicago



The Trane cooperative contract is made available nationwide through the OMNIA Partners portfolio. For more information about OMNIA Partners visit: www.omniapartners.com/publicsector



Trane – by Trane Technologies (NYSE: TT), a global climate innovator – creates comfortable, energy efficient indoor environments through a broad portfolio of heating, ventilating and air conditioning systems and controls, services, parts and supply. For more information, please visit trane.com or tranetechnologies.com.

All trademarks referenced in this document are the trademarks of their respective owners.

© 2022 Trane. All Rights Reserved.

Cooperative Participation

State of Illinois Specific Terms and Conditions

1. This participating agreement executed by the State of Illinois may be designated as available to all or certain governmental units and/or qualifying not for profit agencies. "Governmental unit" means State of Illinois, any State agency as defined in Section 1-15.100 of the Illinois Procurement Code (30 ILCS 500/), officers of the State of Illinois, any public authority which has the power to tax, or any other public entity created by statute. 30ILCS 525/.
2. In no event will the total term of any participating agreement, including the initial term and any extensions or amendments, exceed ten (10) years.
3. This participating agreement and all related public records maintained by, provided to, or required to be provided to the State, are subject to the Illinois Freedom of Information Act notwithstanding any provision to the contrary that may be found in this contract. 5 ILCS 140.
4. Any participating agreement executed by the State of Illinois is contingent upon and subject to the availability of funds. The State of Illinois, at its sole option, may terminate or suspend any participating agreement, in whole or in part, without penalty or further payment being required, if (1) the Illinois General Assembly or the Federal funding source fails to make an appropriation sufficient to pay such obligation, or if funds needed are insufficient for any reason (30 ILCS 500/20-60), (2) the Governor of Illinois decreases the Agency's funding by reserving some or all of the Agency's appropriation(s) pursuant to power delegated to the Governor by the Illinois General Assembly, that a reduction is necessary or advisable based upon actual or projected budgetary considerations. Vendor will be notified in writing of the failure of appropriation or of a reduction or decrease.
5. Any claim against any State of Illinois, any State of Illinois agency as defined in Section 1-15.100 of the Illinois Procurement Code (30 ILCS 500/), or officers of the State of Illinois arising out of any participating agreement must be filed exclusively with the Illinois Court of Claims. 705 ILCS 505/1. Payments, including late payment charges, will be paid in accordance with the State Prompt Payment Act and rules when applicable. 30 ILCS 540; 74 Ill. Adm. Code 900. This shall be Vendor's sole remedy for late payments by the State of Illinois. Payment terms contained in Vendor's invoices shall have no force or effect. The State of Illinois shall not enter into binding arbitration to resolve any dispute arising out of any participating agreement. The State of Illinois does not waive sovereign immunity.
6. Illinois may further evaluate the lead entity's awarded contracts to make best value determinations.
7. Registration in the Illinois Procurement Gateway is required before a participating agreement with the State of Illinois may be executed. For information on registration, please visit www.ipg.vendorreg.com.
8. Registration in BidBuy is required before a contract with the State of Illinois can be executed. For information on registration, please see the BidBuy [Vendor Registration Manual](#).
9. Any vendor with a participating agreement may be required to meet an Illinois Business Enterprise Program goal (30 ILCS 575/).
10. Any vendor with a participating agreement may be required to meet a contracting goal with Illinois small businesses (30 ILCS 500/45-90).

Bid Solicitation: 22-510CPOGS-CPOGS-B-25977

Header Information

Bid Number:	22-510CPOGS-CPOGS-B-25977	Description:	PB JPMC for K-12 PPE with Trane	Bid Opening Date:	12/01/2021 12:00:00 PM
Purchaser:	Alexandria Wilson	Organization:	CPOGS - CPO Office for General Services		
Department:	CPOGS51001 - Chief Procurement Office Of General Services	Location:	AA001 - Chief Procurement Office Of General Services		
Fiscal Year:	22	Type Code:	15 - Request for Proposal (RFP)	Allow Electronic Quote:	No
Alternate Id:	15-JLP-023	Required Date:		Available Date :	11/15/2021 09:31:54 AM
Info Contact:	Contact Alexandria Wilson at Alexandria.Wilson@Illinois.gov	Bid Type:	OPEN	Informal Bid Flag:	Yes
Purchase Method:	Open Market				

Pre Bid Conference: N/A

Bulletin Desc: THIS IS NOT A BID OPPORTUNITY. Piggyback JPMC for K-12 Personal Protective Equipment (PPE) and other included cooperative contract offerings that will be available to governmental units and qualified not-for-profit agencies denoted in the piggyback contract.

Ship-to Address:	CPO-GS Executive Assistant 401 S Spring St Stratton Rm 520 Springfield, IL 62706 US Email: diana.siegrist@Illinois.gov Phone: (217)558-2231	Bill-to Address:	CPO-GS Executive Assistant 401 S Spring St Stratton Rm 520 Springfield, IL 62706 US Email: diana.siegrist@Illinois.gov Phone: (217)558-2231	Print Format:	
-------------------------	--	-------------------------	--	----------------------	--

File Attachments: [Notice of Award Form - Trane SIGNED.pdf](#)

Form Attachments:

Required Quote Attachments

SPO Name: Sandy Robinson

Is this a Small Business Set Aside Procurement?: No

Is there a BEP/VBP Participation Goal?: No

Link to Original Contract :

Amendments:

Amendment #	Amendment Date	Amendment Note
1	12/16/2021 09:54:28 AM	The purpose of this amendment is to attach the SPO-signed Notice of Award. THIS WAS NOT A BID OPPORTUNITY - THE VENDOR AND COOPERATIVE HAVE ALREADY BEEN SELECTED FOR PIGGYBACK. Attachment File Changes: Header 1. File 'Notice of Award Form - Trane SIGNED.pdf': File 'Notice of Award Form - Trane SIGNED.pdf' added .

Item Information

Item # 1: (345 - 74) JPMC Piggyback for K-12 Personal Protective Equipment and other included cooperative contract offerings.

NIGP Code: 345-74
Personal Protective Equipment (PPE), Blood Borne Pathogen Protection, (Not Otherwise Classified)

Qty	Unit Cost	UOM	Total Discount Amt.	Tax Rate	Tax Amount	Total Cost
-----	-----------	-----	---------------------	----------	------------	------------

1.0		EA - Each				
-----	--	-----------	--	--	--	--

Manufacturer:

Brand:

Model:

Make:

Packaging:

Additional NIGP Code : 345-00

Bid Tab

Close Window

Copyright © 2022 Periscope Holdings, Inc. - All Rights Reserved.
ILLINOIS_ILI_AWS_PROD_BUYSPED_1_bso



Notice of Award Form

Agency and Awarded Vendor Information

Description:

Bid Number: Agency:

Vendor Selected for Award:

Line Item Description:

Total Award Amount Number of unsuccessful bidders/offerors

Terms (Add Renewal Terms as appropriate)	Length	Value
Initial Term	1 year	\$0 Indefinite JPMC
Add Renewal Term 1,2,3	Delete Renewal Term	

Farm Leases and Concessions

Value to the State:

Estimated Financial Return to the State for the Life of the Contract (Includes Renewals)

Value to the Vendor:

Estimated Gross Revenue to the Vendor for the Life of the Contract (Includes Renewals)

Business Enterprise Program/Veterans Business Program

Awarded bidder/offeror BEP/VBP Utilization Plan Goals 30 ILCS 575/7 (6)

% of VBP Per Utilization Plan: % of BEP Per Utilization Plan:

List each bidder or offeror's name	Total bid amount	The name(s) of the certified BEP firm(s) identified in the bidder's or offeror's submitted utilization plan	The bid's <i>Amount</i> awarded to certified BEP firms identified in the utilization plan	The <i>Percentage</i> of the bid's amount awarded to certified BEP firms identified in the utilization plan

*NA indicates that the offeror's pricing remained sealed.



Notice of Award Form

Agency Contact

Contact Name:	Alexandria Wilson	Telephone Number:	(217)685-0567
Email Address:	Alexandria.Wilson@Illinois.gov	Fax Number:	
Street Address:	401 S. Spring Street	City:	Springfield
State:	Illinois	Zip Code:	62706

SPO Written Determination for Contract Award Decision

- General** - Applies to Split Awards, Award to Other than Lowest Responsible and Responsive Bidder. The Rationale described by the purchasing agency in the recommendation to award seems reasonable, and serves as the basis for the contract decision.
- Invitation for Bid** - The contract was procured through the Invitation for Bid Process, and the contract has been awarded to the lowest priced responsive and responsible bidder.
- Request for Proposal** - Based on factors set forth in the Request for Proposal, the contract has been awarded to the offeror whose proposal is most advantageous to the State.
- Renewal** - The contract is a renewal in accordance with the terms of the existing contract. The award decision is based on justification presented by the purchasing agency's justification.

Other:

Signature Field Digitally signed by Sandy E. Robinson II
Date: 2021.11.17 10:00:27 -06'00'

Date:

To: Kendall County Finance Committee
 From: Antoinette White, Grounds and Natural Resources Division Supervisor
 RE: Grounds Maintenance Full Time Salaries – Market Adjustment Study
 Date: May 26, 2022

Below is a summary of the Full-Time Grounds Maintenance salaries and benefits. The summary includes two scenarios of salary increases with budget impacts.

The first scenario is with a 4% increase starting July 2, 2022 and an additional 4% increase December 1, 2022 (extending to November 30, 2023).

The second scenario is with an 8% increase effective December 1, 2022 (extending through November 30, 2023).

Dept	Total Salary	Total Benefits	Total Compensation	Per Pay Period Salary	Total Take Home Per Pay Period (2 weeks)	Total salary pay out difference at 4% 10 Pay Periods	Total Salary Pay Difference with additional 4% FY23	Total Increase From July 2, 2022 to November 30, 2023	Total Increase from 12/1/22 to 11/30/23 at 8%
GM-H	\$33,510.88	\$16,843.25	\$50,354.13	\$1,288.88	\$950.62	\$515.55	\$1,394.05	\$1,909.60	\$2,680.87
GM-ARPA	\$33,110.00	\$16,329.34	\$49,439.34	\$1,273.46	\$938.31	\$509.38	\$1,377.38	\$1,886.76	\$2,648.80
GM	\$33,904.00	\$16,445.42	\$50,349.42	\$1,304.00	\$1,021.37	\$521.60	\$1,410.41	\$1,932.01	\$2,712.32
								\$5,728.37	\$8,041.99

The agencies below were contacted to review total compensation packages. Below is a comparison of average benefit packages of other local counties and cities. Benefit packages include IMRF at 6.97% of total salary; FICA at 7.65% of total salary, plus medical, dental and life insurance.

	Average Additional Compensation
Forest Preserve District of Will County	\$ 18,364.00
Kane County	\$ 16,510.75
City of Yorkville	\$ 21,357.80
Kendall County Forest Preserve District	\$ 16,539.34

Recommendations:

Based on discussions held with District Grounds Maintenance full time staff members, District staff recommends approval of an initial inflation relief and market adjustment increase of 4% for all full-time Grounds Maintenance Workers effective July 2, 2022, with an additional 4%-6% to be considered within fiscal constraints of the FY23 budget. Total impact to the FY22 budget is \$1,546.53. Position vacancies due to difficulties in securing part time employees have generated significant salary savings over the proposed expenditures.

To: Kendall County Finance Committee

From: Antoinette White, Grounds and Natural Resources Division Supervisor

RE: Grounds Maintenance Staffing Updates: Market Research and YTD Salary Expenditures Analysis

Date: April 28, 2022

Current Staff Salaries

Kendall County Forest Preserve District Grounds and Natural Resources Division Supervisor
\$42,780.00

Kendall County Forest Preserve District Hoover Grounds Supervisor and Resident
\$57,067.90

Kendall County Forest Preserve District Salary of Preserve Grounds and Projects Manager
\$37,806.00

Kendall County Forest Preserve District Salary Range of FT Grounds Maintenance
\$32,600.00 - **\$33,904.00**

Illinois Average Salary of a Grounds Maintenance Worker (Source: Indeed.com)
\$35,251.00 - \$45,367.00

[Home](#) > [Career Explorer](#) > [Grounds Maintenance Worker](#) > [Salaries](#)

Grounds Maintenance Worker salary in Illinois

How much does a Grounds Maintenance Worker make in Illinois?

Average base salary 

\$40,062

Per year 

same as national average

Most common benefits

Overtime
\$5,031 per year

Others
401(k)

[View more](#)

The average salary for a grounds maintenance worker is \$40,062 per year in Illinois and \$5,031 overtime per year. 95 salaries reported updated at April 14 2022.

Is this useful?



Maybe



Other Agencies

DeKalb County Forest Preserve (2020)

- Natural Resource Manager \$56,180.80 to \$69,243.20
- Maintenance Supervisor \$49,920.00 to \$69,243.20
- Maintenance / NR Technician \$29,120.00 to \$38,480.00
- Part Time \$13.00 to \$16.00 /hr.

Yorkville Park and Rec (2023 est.)

- Superintendent of Parks \$115,188.00
- Maintenance Workers \$46,992.00 to \$57,607.00

Oswegoland Park District

- Grounds Crew / Maintenance Starting: \$24,960

Rockford Park District

- Grounds Maintenance Starting: \$29,120.00

Forest Preserve District of Will County

- Operations Supervisor \$73,860.38 to \$76,810.00
- Natural Resource Management Supervisor \$83,124.91

Forest Preserve District of Kane County

- Grounds Maintenance Worker (hired in 2019) \$36,000.12 to \$39,868.92
- Grounds Maintenance Crew Leader \$49,857.34 to \$62,408.06
- Project Planner \$65,681.72
- Natural Resources Project Coordinator \$68,615.82 to \$87,016.54
- Assistant Manager of Site Operations \$70,583.42
- Manager of Natural Resources \$93,644.72

FY2022 Budget Analysis

As of March 31, 2022 (8 out of 26 pay periods), Grounds and Natural Resources Division salaries are below straight-line budget figures:

Grounds and Natural Resources:	FY22 Budget	YTD (8/26 PP)	%	Budget Straightline YTD	Difference
· Part-time:	\$ 16,764.00	\$ 2,745.25	16.4%	\$ 5,158.15	\$ 2,412.90
· Full-time:	\$ 89,963.00	\$ 25,422.71	28.3%	\$ 27,680.92	\$ (563.79)
Hoover Grounds:					
· Part-time:	\$ 36,752.52	\$ 6,013.96	16.4%	\$ 11,308.47	\$ 5,294.51
· Full-time	\$ 90,578.00	\$ 25,431.29	28.1%	\$ 27,870.15	\$ 2,438.86
ARPA					
· Part-time:	\$ 17,280.00	\$ -			\$ -
· Full-time:	\$ 32,600.00	\$ 8,984.62	27.6%	\$ 10,030.77	\$ 1,046.15
Total Salary Savings over Straightline Expenditures					\$ 10,628.64

Recommendation:

Consider market adjustment salary increases for full time Grounds Maintenance Worker (3) positions and the Grounds and Natural Resources Division Supervisor position.

O'Malley Welding and Fabricating, Inc.

1209 Badger St
 Yorkville IL 60560
 630-553-1604

QUOTE

DATE	QUOTE NO.
3/14/2022	1210

NAME / ADDRESS
Kendall County Forest Preserve 110 W Madison ST Yorkville, IL 60560

Ship To

P.O. NO.	TERMS
	Net 30

DESCRIPTION	QTY	COST	TOTAL
Maramech Entry Gate: Field measure and verify, provide shop drawings for approval, fabricate, and install Minooka style gate. Provide sandblasting, 2- coat powder coat. Outside sourced labor: Provide 24" x 4' concrete footing		8,150.00	8,150.00
		2,400.00	2,400.00

Sales Tax (8.25%)	\$0.00
TOTAL	\$10,550.00

Fax #
630-553-1605



To: Kendall County Finance Committee
From: Antoinette White, Grounds and Natural Resources Division Supervisor
RE: District Equipment Auction Recommendations Report
Date: May 26, 2022

The District has replaced the Hoover Cub Cadet (2182) with the purchase from DeKane Equipment, Big Rock, IL of a new Cub Cadet (XT2). DeKane Equipment was not interested in a trade in of the Cub Cadet (2182).

District Staff is recommending selling unused equipment on Govdeals.com. Govdeals.com is a website for public to bid on items sold strictly by government entities.

The equipment recommend to sell:

- Mower - Riding 1995 John Deere series 525 Harris Serial# MOF525A140214
- Mower - Riding Cub Cadet 2182 60" Deck - USED HooverModel #142743100 / Serial #826222

The 1995 John Deere (series 525) mower is not currently used and would not be recommend for repairs.

The Cub Cadet (2182) mower has \$1,400 in estimated repair costs.

District staff recommends listing the above mowers for sale on Govdeals.com with items for pick-up only, and full fees being placed on the buyer.

Client Name

City, State

Online Sales - Terms and Conditions

All bidders and other participants of this service agree they have read and fully understand these terms and agree to be bound thereby.

Guaranty Waiver. All assets are offered for sale “AS IS, WHERE IS.” **Client Name (Seller)** makes no warranty, guaranty or representation of any kind, expressed or implied, as to the merchantability or fitness for any purpose of the property offered for sale. The Buyer is not entitled to any payment for loss of profit or any other money damages – special, direct, indirect or consequential.

Description Warranty. **Seller** warrants to the Buyer the property offered for sale will conform to its description. Any claim for misdescription must be made prior to removal of the property. If **Seller** confirms the property does not conform to the description, **Seller** will keep the property and refund any money paid. The liability of the **Seller** shall not exceed the actual purchase price of the property. **Please note upon removal of the property, all sales are final.**

Personal and Property Risk. Persons attending during exhibition, sale, or removal of goods assume all risks of damage of or loss to person and property and specifically release the **Seller** and **GovDeals** from liability therefore.

Consideration of Bid. **Seller** reserves the right to reject any and all bids and to withdraw from sale any of the assets listed at any time until the Seller has received payment in full for the assets and Buyer has removed the assets from the Seller's premises in their entirety.

Buyer's Certificate. If applicable, successful bidders will receive a Buyer's Certificate by email from **GovDeals** as their notice of award.

Buyer's Premium & Additional Fees. If a Buyer's Premium and/or Additional Fees are shown on the auction page Bid Box, then that amount (expressed as a percentage of the final selling price or a specified amount) will be added to the final selling price of all items in addition to any taxes imposed.

Payment. Payment in full is due not later than **5 business days** from the time and date of the close of the auction. Please refer to the payment instructions listed on the auction page for complete payment terms and methods. Please refer to the Bid Box for all fees and taxes that may be associated with the auction.

State/Local Sales and/or Use Tax. Buyers are subject to State and/or local sales and/or use tax unless they provide a proper exemption certificate. Please review the Payment Instructions for all information related to Sales Tax and Tax Exemptions.

Removal. All assets must be removed within **ten (10) business days** from the time and date of the close of the auction. Purchases will be released only upon receipt of payment as specified. Successful buyers are responsible for loading and removal of any and all property awarded to them from the place where the property is located as indicated on the website and in the Buyer's Certificate. The Buyer will make all arrangements and perform all work necessary, including packing, loading and transportation of the property. Under no circumstances will **Seller** assume responsibility for packing, loading or shipping. See instructions

on each auction page for complete removal details. A daily storage fee of \$25.00 may be charged for any item not removed within the ten (10) business days allowed and stated on the Buyer's Certificate.

Vehicle Titles. Seller will issue a title or certificate upon removal of the vehicle. Titles may be subject to restrictions as indicated in the asset description on the website.

Approval. Some Auctions/Sales are subject to Seller approval prior to award to the high bidder. Please review the auction/sale page for full terms of the sale and whether the final bid/sale is subject to approval.

Default. Default shall include (1) failure to observe these terms and conditions; (2) failure to make good and timely payment; or (3) failure to remove all assets within the specified time. Default may result in termination of the contract and suspension from participation in all future sales until the default has been cured. If the Buyer fails in the performance of their obligations, **Seller** may exercise such rights and may pursue such remedies as are provided by law. **Seller reserves the right to reclaim and resell all items not removed by the specified removal date.**

Acceptance of Terms and Conditions. By submitting a bid, the bidder agrees they have read, fully understand and accept these Terms and Conditions, and agree to pay for and remove the property, by the dates and times specified. These Terms and Conditions are available for review in the bid box at the top of each page of each asset listed on GovDeals. Specific Instructions (Payment, Removal, and Special) appearing on the asset page will override certain sections of these Terms and Conditions.

Sales to Employees. Employees of the **Seller** may bid on the property listed for auction, so long as they do NOT bid while on duty.

Liquidity Services Operations LLC dba GovDeals

Financial Settlement Services (FSS) Addendum

This Addendum is between Liquidity Services Operations LLC dba GovDeals, Inc. ("GovDeals"), a Delaware corporation having its principal place of business at 100 Capitol Commerce Blvd. Suite 110, Montgomery, Alabama 36117, and _____ (Client) having its principal place of business at _____.

It is understood the Client elects GovDeals to collect all proceeds due the Client from the winning bidder and remit the proceeds to the Client less the GovDeals fee.

GovDeals will charge the winning bidder a "Buyer's Premium", therefore, the Client is not allowed to charge the winning bidder an additional "Buyer's Premium".

GovDeals will collect all proceeds from the winning bidder, including the "Buyer's Premium" through PayPal, credit card or wire transfer. This is the only means of payment by the bidder.

The Client will not release an asset to the winning bidder until the Client has received verification from GovDeals that payment has been received from the winning bidder. Prior to an item being released to the winning bidder, the Client will ensure the winning bidder or his/her agent has signed a "Bill of Sale" containing the following notation: "Asset is sold as is, where is and without warranty. Once the asset is removed from the seller's premises there is no refund of monies previously paid". The Bill of Sale must be printed from the Seller Asset Management (SAM). Any other "Bill of Sale" used by the Client must be submitted to GovDeals for approval.

No proceeds will be remitted to the Client for any asset sold without verification of payment from GovDeals and verification from the Client the item has been picked up by the winning bidder. Approved payment from the winning bidder through PayPal, credit card, or wire transfer will be noted in SAM. It is the Client's responsibility to notify GovDeals when an item has been picked up, which is accomplished by the Client accessing SAM and selecting the "Picked Up" option from the "Paid, not picked up" report.

GovDeals will remit all proceeds collected, less the "Buyer's Premium" and the GovDeals fee to the Client on a weekly basis for all assets marked in SAM as 'Picked Up'. All proceeds will be remitted electronically by Automatic Clearing House/Electronic Funds Transfer (ACH/EFT). A detailed backup will be submitted to the Client to support the amount remitted.

Under no circumstance will the Client collect any proceeds directly from the winning bidder and if requested to do so, the Client should refer the winning bidder directly to GovDeals for payment instructions.

GovDeals will absorb all costs of Charge Backs by PayPal or a credit card company where an item is released to the winning bidder after the Client receives proper payment notification from GovDeals, GovDeals receives proper pickup notification from the Client and the Client obtained and retained a signed "Bill of Sale" from the winning bidder.

GovDeals will refund proceeds collected to the winning bidder in those rare occasions where the winning bidder pays for an asset but never picks it up and subsequently convinces PayPal or the credit card company to withdraw the amount from GovDeals' bank account. It is the Client's responsibility to request a credit on the asset paid for but not picked up as soon as the allowable pick up time passes. By taking the credit, it insures GovDeals will not charge the Client a fee and will allow the Client to resell the asset. If the asset is mistakenly placed in 'picked up' status by the Client and GovDeals has remitted payment, the Client agrees to refund this amount back to GovDeals.

A GovDeals' Client Account Manager or a GovDeals Help Desk Representative will train the Client on how to effectively use the Financial Settlement Services feature and provide ongoing support as needed. There are no additional costs to the Client for training and support.

GovDeals is covered by a Crime Insurance Policy with a limit of \$5,000,000, which will protect the Client against any loss of funds.

David Guritz

Subject: FW: [External]RE: Billing Spreadsheet
Attachments: Groot \$524.64 (19001183 63070-\$415.09, 19001168 63070-\$109.56).pdf

From: David Guritz
Sent: Thursday, May 26, 2022 2:18 PM
To: Julia J. Granholm <jgranholm@kendallcountyil.gov>
Cc: Steven Markulin <steven.markulin@wasteconnections.com>
Subject: RE: [External]RE: Billing Spreadsheet

Julia:

Per Steve's email below, we should see a \$782.96 credit post to the Groot billing statement for June.

I have attached our most recent statement as well.

Our current monthly billing total per agreement, April through November, is \$524.64.

The Groot billing statements appear a bit off, so for June, pay nothing to begin to draw down the credit.

For July, pay as follows: \$524.64 monthly amount owed - 258.32 remaining credit = \$266.32

KCFPD Payments	Service Dates	District payments	Contract Amounts Owed
12-May-21	May 1-31	\$ 500.61	\$ 500.61
9-Jun-21	June 1-30	\$ 504.71	\$ 500.61
14-Jul-21	July 1-31	\$ 875.61	\$ 500.61
12-Aug-21	August 1-31	\$ 500.61	\$ 500.61
15-Sep-21	September 1-30	\$ 500.61	\$ 500.61
13-Oct-21	October 1-31	\$ 500.61	\$ 500.61
9-Nov-21	November 1-30	\$ 500.61	\$ 500.61
15-Dec-21	December 1-31	\$ 500.61	\$ 256.99
12-Jan-22	Jan 1-31	\$ 500.61	\$ 256.99
9-Feb-22	Feb 1-28	\$ 548.61	\$ 256.99
Less Additional Service Requests/Previous Credits		\$ (375.00)	
Total paid on monthly service owed		\$ 5,058.20	\$ 4,275.24
Amount to be Credited to KCFPD		\$ 782.96	

That will take care of the credit, and we can resume regular payments beginning in August.

Thanks!

Dave

Dave Guritz
Director
Kendall County Forest Preserve District
(630) 553-4131
dguritz@co.kendall.il.us

To: Kendall County Forest Preserve District Finance Committee
From: David Guritz, Executive Director
RE: Rt. 71 Path IGA Status Report and IDOT Letter of Agreement
Date: May 26, 2022

The final draft of the IDOT-Letter of Agreement is attached for review.
The following is the anticipated schedule for approval of the IGA.

Kendall County Scheduled Date for Approval	June 7, 2022
United City of Yorkville Scheduled date for Approval	June 28, 2022 (latest date for approval)
Village of Oswego Scheduled date for Approval	June 14 or June 27

Recommendation

District staff recommends approval of the final IDOT Letter of Agreement at the June 21, 2022 Commission meeting, subject to approval of the Rt. 71 Shared Use Path Intergovernmental Agreement by all parties to the agreement.



Illinois Department of Transportation

Office of Highways Project Implementation / Region 2 / District 3
700 East Norris Drive / Ottawa, Illinois 61350-1628

January 2022

Judy Gilmour, President
Kendall County Forest Preserve District
110 West Madison Street
Yorkville, IL 60560

LETTER OF UNDERSTANDING

FAP 311 (IL 71)

Section (1-1)R,BR1

Kendall County

Reconstruction from East of IL 126 to Orchard Road

Job No. C-93-019-14

Contract No. 66D26

Dear President Gilmour:

As previously discussed, the Illinois Department of Transportation (IDOT), District 3 office in Ottawa is currently preparing plans for the improvement of Illinois Route 71. The project limits are from east of Illinois Route 126 in Yorkville to Orchard/Minkler Road in Oswego.

The proposed improvement involves the removal of the existing pavement and construction of new pavement to provide two lanes in each direction with a raised median, turn lanes where warranted, storm sewer, modernization of traffic signals, curb and gutter, drainage improvements, bicycle and pedestrian accommodations, and safety improvements. Existing SN 047-0059 carrying IL Route 71 over Morgan Creek will be removed and replaced with a proposed triple 12'X10' box culvert. A shared use path is to be constructed the length of the project.

Based on previous discussions, the Kendall County Forest Preserve expressed its willingness to share in the cost of construction of a section of the shared use path from the City of Yorkville corporate limits to Orchard Road, except for any property within the corporate limits of a municipality. Recently, there has been a change in the federal/state policy pertaining to the local agency cost participation associated with the shared use path beginning January 2022. The State will now pay 100% of all costs for the construction on new paths within the project termini as long as the local agency agrees to maintain the path.

This Letter of Understanding serves to formally confirm that the Kendall County Forest Preserve is desirous to have the shared use path constructed at the location noted above and agrees to maintaining the path.

Matters of the shared use path relevant to the Village of Oswego and the City of Yorkville will be addressed in separate letters of understanding respectively with Oswego and Yorkville.

The proposed improvement is currently funded for Fiscal Year 2022, subject to plan readiness.

Please mark the appropriate response in the box and sign below to indicate if you concur or not with proposed improvement and maintenance responsibilities. If you do not concur with any or all the proposed improvements or responsibilities, please provide any comments explaining the reasons and any changes you recommend. Return one copy of the letter to the IDOT District 3 office in Ottawa and retain the second for your files.

Contract No. 66D26

- The Kendall County Forest Preserve agrees to the maintenance responsibilities as stated above.
- The Kendall County Forest Preserve does not agree to the maintenance responsibilities as stated above. (please provide comments below)

Comments

Kendall County Forest Preserve District agrees to the maintenance responsibilities for the above IDOT-constructed shared-use path.

An intergovernmental agreement between the Kendall County Forest Preserve District, Kendall County, United City of Yorkville, and Village of Oswego has been entered into by all parties setting forth the conditions for the long term maintenance of the shared-use path.

KCFPD-IGA approval date: 05/17/2022

Judy Gilmour, President

Date

If you have any questions or require further information, please contact Mr. Brad Duncan, Studies & Plans Project Engineer, at (815) 434-8420.

Sincerely,

Masood Ahmad, P.E.
Region Two Engineer

By: Scott Ferguson, P.E.
Acting Studies and Plans Engineer

David Guritz

Subject: FW: Lower Little Rock Creek Dam Removal Project

From: David Guritz

Sent: Tuesday, May 3, 2022 6:54 PM

To: Steve Zimmerman <szimmerman@res.us>

Cc: Tim Moritz <tmoritz@res.us>; Antoinette White <awhite@co.kendall.il.us>

Subject: Lower Little Rock Creek Dam Removal Project

Steve:

I heard back from County & received some positive news.

Looks like the target for total project budget if we were working to complete this project within the next two years (including consulting fees, Section 319 grant application, permitting, and construction) would need to come in at no more than \$400,000. That's the cash on hand, with the Section 319 reimbursing \$160,000 that could be used potentially for a second phase of work.

Presuming the District would have its rolling grant fund established, available and unobligated by 2024, this total project figure could be potentially increased to a total project budget of \$650,000 with a reimbursable Section 319 award of \$260,000 (40%) that could be used potentially for a second phase of work.

<https://www2.illinois.gov/epa/topics/water-quality/watershed-management/nonpoint-sources/Documents/NOFO-S319-FY22.pdf>

Some time ago, Steve Pescitelli suggested that just the removal of the dam structure would likely be in the range of \$200,000.

Site equipment access could pose some challenges, so I would suggest thinking about alternative approaches.

If you would like the District to consider a first phase construction estimating effort, with Section 319 grant application, we'd could present the concept ideas and approaches to the Board of Commissioners for discussion.

Scope of work should examine opportunities for immediate upstream and downstream habitat enhancement projects (Phragmites control and upstream wetlands restoration; "overflow" pond erosion control and shoreline improvements; shoreline stabilization and seeding/planting) prioritized within the overall project budget.

U of I – INHS will be surveying for mussels this summer, and there are State-listed species present that will require IDNR-ITA along with USACoE permits.

Sincerely,

Dave

Dave Guritz

Director

Kendall County Forest Preserve District

(630) 553-4131

From: Matt Asselmeier
Sent: Tuesday, May 3, 2022 1:35 PM
To: David Guritz <dguritz@co.kendall.il.us>; Scott Koeppel <skoeppe@kendallcountyil.gov>
Subject: RE: Little Rock Creek Watershed Planning - Kendall County Stormwater Impact Fees

Dave:

There is \$387,000 in the Fox River Watershed Escrow Account.

Thanks,

Matthew H. Asselmeier, AICP, CFM
Senior Planner
Kendall County Planning, Building & Zoning
111 West Fox Street
Yorkville, IL 60560-1498
PH: 630-553-4139
Fax: 630-553-4179

From: David Guritz
Sent: Tuesday, May 3, 2022 1:27 PM
To: Scott Koeppel <skoeppe@kendallcountyil.gov>; Matt Asselmeier <masselmeier@co.kendall.il.us>
Subject: Little Rock Creek Watershed Planning - Kendall County Stormwater Impact Fees

Scott & Matt:

Do you have an approximate amount available so the District can structure our proposal accordingly?

We would likely want to pursue federal grant funds (EPA Section 319) to stretch out the funds available.

As far as cash flow, it would be difficult for the District to underpin the costs for this project anytime in the next 2-3 years. Our capital funds are tied up with other projects.

If the Kendall County Board could transfer the total estimated cost of the project with the provision that unused funds are returned, that would be the best approach as far as the District is concerned.

We will want to check in with the State's Attorney's Office to make sure this arrangement would be acceptable. I would also need to know that total amount Kendall County would be able/willing to extend so we handle the project budget accordingly.

If, for example, dam removal (\$250,000) + shoreline/habitat restoration (\$350,000) produces a \$600,000 project budget, with EPA Section 319 funds extending \$240,000 (40%), would KC extend the full \$600,000, less \$240,000 reimbursed by the grant?

Thanks in advance for your clarifications.

Sincerely,

Dave Guritz
Director
Kendall County Forest Preserve District
(630) 553-4131
dguritz@co.kendall.il.us

From: Scott Koepfel
Sent: Tuesday, May 3, 2022 1:09 PM
To: Matt Asselmeier <masselmeier@co.kendall.il.us>; David Guritz <dguritz@co.kendall.il.us>
Subject: RE: [External]RE: Little Rock Creek Watershed Planning - Kendall County Stormwater Impact Fees

Dave,

If you can get a proposal in front of a committee of the commission and then send a formal request to the Planning, Building, and Zoning Committee we can get this project moving.

Thank you,

Scott Koepfel

From: Matt Asselmeier <masselmeier@co.kendall.il.us>
Sent: Monday, May 2, 2022 6:29 PM
To: David Guritz <dguritz@co.kendall.il.us>
Cc: Scott Koepfel <skoepfel@kendallcountyil.gov>
Subject: FW: [External]RE: Little Rock Creek Watershed Planning - Kendall County Stormwater Impact Fees

Dave:

Please see the following information from Greg Chismark.

Thanks,

Matthew H. Asselmeier, AICP, CFM
Senior Planner
Kendall County Planning, Building & Zoning
111 West Fox Street
Yorkville, IL 60560-1498
PH: 630-553-4139
Fax: 630-553-4179

From: Greg Chismark [mailto:gchismark@wbkengineering.com]
Sent: Monday, May 2, 2022 4:54 PM
To: Matt Asselmeier <masselmeier@co.kendall.il.us>
Cc: Scott Koepfel <skoepfel@kendallcountyil.gov>
Subject: RE: [External]RE: Little Rock Creek Watershed Planning - Kendall County Stormwater Impact Fees

Matt,

I think the County Board can transfer the funds and there are probably several different ways that can happen.

First though, I am assuming the FPD would formally request funding to the Board for approval with a description of the project and estimated project cost. At that point the County could approve the project and agree to support with of fee-in-lieu funds.

The Board could make this a reimbursement arrangement after expenses are incurred and submitted to the Board for reimbursement.

The Board could authorize a transfer after a contract is entered into by the Forest Preserve, with a provision that unused funds are returned.

The Board could transfer the total estimated cost of the project prior to any contract with the provision that unused funds are returned.

There is nothing in the ordinance that says how this is to be handled. I think it is up to the Board how much control they want and how much of a process they want to create.

Hope this helps.

Greg

Greg Chismark, PE

President

Direct: (630) 338-8527 | Main: (630) 443-7755

gchismark@wbkengineering.com

WBK Engineering, LLC

116 W. Main Street, Suite 201, St. Charles, IL 60174

From: Matt Asselmeier <masselmeier@co.kendall.il.us>

Sent: Monday, May 2, 2022 2:16 PM

To: Greg Chismark <gchismark@wbkengineering.com>

Cc: Scott Koeppel <skoeppel@kendallcountyil.gov>

Subject: RE: [External]RE: Little Rock Creek Watershed Planning - Kendall County Stormwater Impact Fees

To be clear, the funds can be transferred from one taxing body to another?

Thanks,

Matthew H. Asselmeier, AICP, CFM

Senior Planner

Kendall County Planning, Building & Zoning

111 West Fox Street

Yorkville, IL 60560-1498

PH: 630-553-4139

Fax: 630-553-4179