

DRAFT
November 12, 2024



**2024 – 2044
Long Range
Transportation Plan**



NOVEMBER 19, 2024

Table of Contents

Introduction	-3-
Existing Highway System	-4-
Expected Deficiencies Created by New Growth	-4-
Current & Anticipated Transportation Funding	-5-
Motor Fuel Tax	-5-
County Highway Fund	-7-
County Bridge Fund	-8-
Federal Aid Matching Fund	-9-
Transportation Sales Tax Funds	-9-
Federal Funds	-10-
Needed Highway / Bridge Improvements	-11-
Intersection Improvements	-11-
Capacity Improvements	-11-
Bridge Improvements	-11-
Maintenance & Pavement Preservation	-12-
Assumptions	-13-
Analysis	-14-
Conclusion	-15-
 List of Exhibits	
Exhibit 1:	Historical Highway Department Funding
Exhibit 2:	Tax Levy Data
Exhibit 3:	Estimated Annual Funding Levels for Capital Improvements
Exhibit 4:	Consumer Price Index (2008-2023)
Exhibit 5:	2024-2044 Anticipated Capital Improvements
Exhibit 6:	Capital Improvement Map
Exhibit 7:	Financial Analysis of 2024-2044 Transportation Plan
Exhibit 8:	Projected Future Traffic
Exhibit 9:	Design Standards
Exhibits 9a – 9e:	Geometric Features
Exhibit 10:	5-Year Transportation Plan – Revised 9/17/24

Introduction

Between the years 2000 and 2010, Kendall County, Illinois was identified as the fastest growing county in the nation, based on the percentage increase in population. The 2020 decennial census confirmed continuing growth, as Kendall County was, by far, the fastest growing county in the State of Illinois for the decade 2010 - 2020. The County has obviously experienced a very robust economy for nearly two decades. The dramatic downturn in the economy near the end of the last decade, which brought a sudden halt to the housing market, is fading rapidly as both residential and commercial growth currently abound in many areas of Kendall County.

Numerous opportunities, and some obstacles too, will result from the many changes this county has been experiencing; not the least of which is an anticipated strain on the transportation system. All highway agencies and all modes of transportation will be affected. This transportation plan does not seek to present a comprehensive, agency-wide and intermodal solution, but will simply focus on the needs of the County Highway System, based on historical and anticipated growth.

Many transportation plans utilize detailed traffic modeling techniques to predict where capacity improvements will be needed. It is an appropriate application of the technology available today to make certain predictions for future transportation needs. This Plan, on the other hand, focuses on long-range transportation improvements and the funding required to make such improvements. It makes logical assumptions for intersection and roadway capacity improvements based on a review of municipal comprehensive plans, historical growth, evaluation of growth trends, and engineering judgment. Specific highway and bridge improvement projects are identified in an effort to estimate the total cost of improving and maintaining the County Highway System over the next 20 years. These project needs are then compared with the County's ability to fund them, given the current and projected revenue streams over the same time period.

In more urban counties, there is frequently more emphasis on public transportation, mass transit, and Intelligent Transportation Systems (ITS) as those counties reach a point where add-lanes projects have diminishing returns. And even though Kendall County has been growing faster than all other counties in Illinois, its total population and population densities are still relatively low compared to other counties in the Chicago Metropolitan Area. With these existing population densities, and those expected during the next 20 years, it is assumed that services provided by PACE and METRA, as well as ITS will play a very limited role in solving Kendall's transportation challenges. Rather, the focus of this plan is to analyze the County Highway System and suggest recommendations that will improve capacity and safety. Additionally, the cyclical nature of residential development was clearly exposed in 2008, when homebuilding stopped, land values decreased, and foreclosures exploded. This also will extend the time period when mass transit will be a viable alternative for the residents of Kendall County.

COVID-19 has created another interesting wrinkle in the delivery of improved transportation networks. As more people are working from home, recent numbers for annualized average daily traffic on many roadways have remained unchanged or even decreased from data obtained 5 years ago. Going forward, it may be more difficult determining which corridors are projected to

see significant increases in traffic, and correspondingly assign capital improvement dollars, as many individuals choose to work remotely on a more permanent basis.

Obviously, any study encompassing the span of 20 years will integrate numerous assumptions and will have certain inaccuracies. We believe that this study, based more heavily on engineering judgment, is not inherently more inaccurate than those based on empirical evaluations.

Existing Highway System

Kendall County currently has about 132 centerline miles (280 lane miles) of pavement and 31 bridges on the County Highway System, including the recently opened Eldamain Bridge over the Fox River. These facilities consist almost entirely of 2-lane-type roadways and bridges, with the exception of the Orchard Road Corridor in Montgomery and Oswego, and small sections of Ridge Road in the City of Joliet and Village of Minooka. There is only one 4-lane bridge on the entire system; that being the Orchard Road Bridge over Burlington Northern Santa Fe (BNSF) Railroad in Oswego.

In general terms, the physical condition of the County Highway System is good. From a capacity viewpoint, the condition is also good, with the exception of a few intersections and short roadway segments in the more urban areas that are rapidly becoming congested.

Expected Deficiencies Created by New Growth

Although the current report card on the County Highway System is good, it is not expected to stay that way indefinitely, unless significant improvements are made to the County Highway System; improvements that will address capacity needs, including intersection improvements, traffic signalization or roundabout construction, as well as some add-lanes projects.

The Chicago Metropolitan Agency for Planning (CMAP) has forecasted that the 2050 population for Kendall County will grow dramatically to nearly 193,000... a 46% increase from the 2020 census population of 131,869. The number of households is also expected to increase proportionally, and employment is projected to grow by a whopping 200%. This growth will put a tremendous burden on the entire transportation network in Kendall County, including state, county, municipal and township facilities.

The projected increase in the number of households in Kendall County will create an estimated 200,000 new daily trips by 2050, compared to the number of trips in 2020. This will add millions of new vehicle-miles per day to the existing system. Much of this new traffic will travel on the County Highway System for at least a part of their average trip.

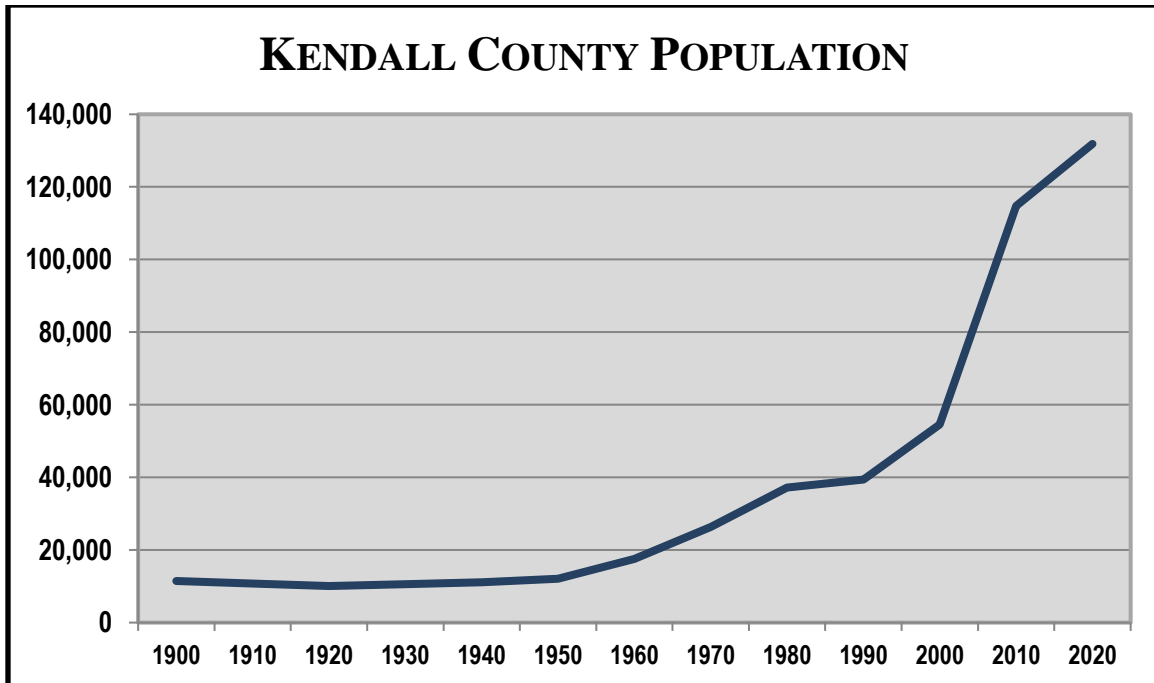

Many of the existing county highways, such as Galena Road, Orchard Road, Plainfield Road, and Ridge Road, simply cannot accommodate the overwhelming increase in traffic. In fact, several of these roadways are already approaching the 2-lane threshold, in which consideration should be given to making capacity improvements. Additionally, the increase in traffic will drive the need for numerous intersection improvements, designed to improve safety at the crowded intersections.

Current & Anticipated Transportation Funding

There are several revenue sources that will help fund the needed capital improvements and provide maintenance for transportation infrastructure on the County System. They are described in some detail herein. Please refer to Exhibit 1, Historical Highway Department Funding, and Exhibit 3, Estimated Annual Funding Levels for Capital Improvements, for more information. These revenues are described in more detail below.

Motor Fuel Tax: Kendall County, like all other counties in the State of Illinois, receives motor fuel taxes based on the number of registered vehicles in the county. According to Illinois Secretary of State, there were 118,018 registered vehicles in Kendall County in 2023. The motor fuel taxes collected can be used for both capital improvements and maintenance. In 2019, the Illinois Legislature approved the Rebuild Illinois Program, which doubled the State Motor Fuel Tax - increasing the gas tax from 19¢ per gallon to 38¢ per gallon, and indexing it to inflation. Additionally, a bonding component of this program provided an additional \$4.1 million dollars to Kendall County in the first 3 years of the program. This is the first increase to MFT in almost 30 years, and will help to fund needed improvements on both the State and Local Highway Systems. Although Kendall County expects to receive a significant increase in Motor Fuel Taxes, the increase represents only about a 15% increase in the overall capital program.

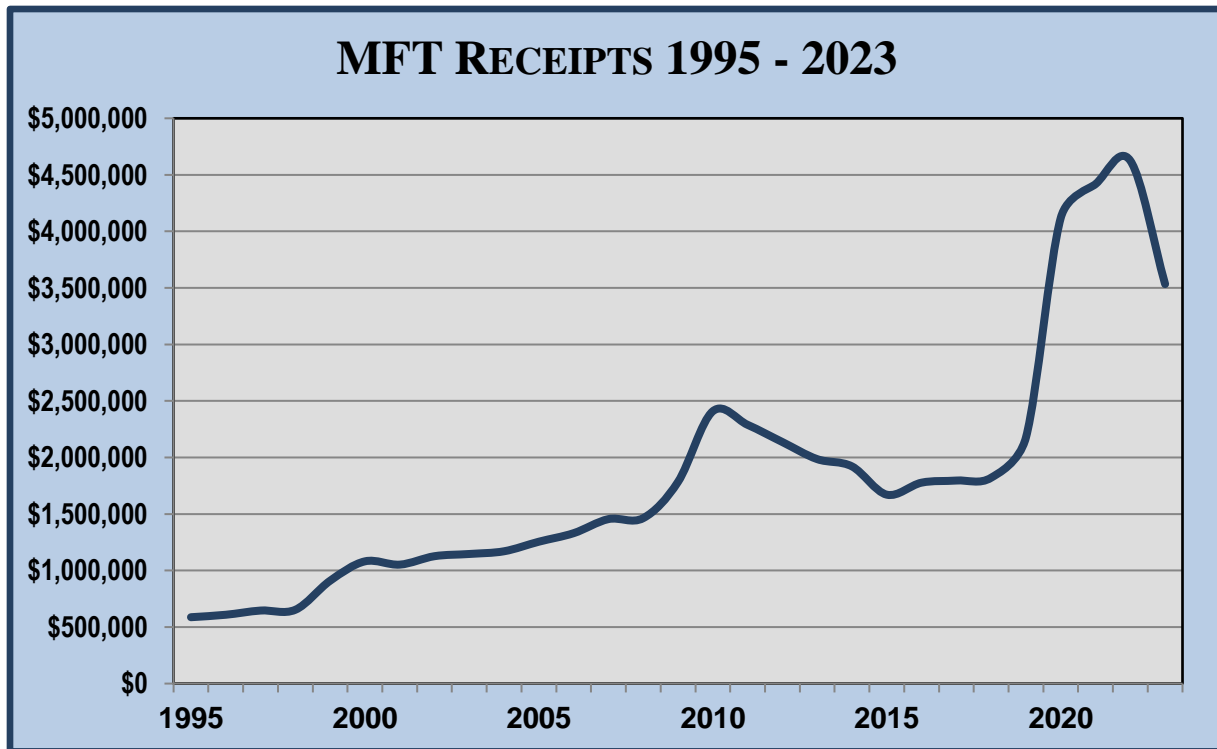

Motor Fuel Tax Trends

- *Continuing increases in population will result in more registered vehicles in Kendall County. Therefore, MFT revenues should trend upwards.*
- *As a result of ReBuild Illinois increases to the State’s motor fuel taxes, all local agencies have seen a significant increase in motor fuel tax revenues beginning in 2020. Additionally, all local agencies are enjoying a 3-year bond component of the legislation, which will add about \$4 million over 3 years to the MFT fund.*
- *A 1.5% per year growth factor is predicted over the next 20 years for County Motor Fuel Taxes (see Exhibit 3 & 7), beginning with estimated receipts of \$3.25 million in 2024.*

As a footnote to the assessment of this fund, it is important to note that Kendall County must be vigilant in evaluating opportunities to more accurately document vehicle registrations for those vehicles with residence in Kendall County. As a county with major populations centers such as Aurora and Joliet located in adjacent counties, and to a lesser degree the cities of Plainfield, Montgomery, Sandwich, and Minooka, there have been many documented cases where vehicles owned by Kendall County residents have been incorrectly registered in the adjacent counties. Kendall County Administrative Services was successful in working with the Secretary of State’s Office on multiple occasions to accurately assign vehicle registrations to the correct counties.

Finally, it is important to note that increases in electric vehicles could someday compromise the collection of motor fuel taxes in Illinois and across the Country. However, as of January 15, 2024, Illinois Secretary of State identified just 877 electric vehicles registered in Kendall County; so this does not appear to be an issue for Kendall County in the near term.

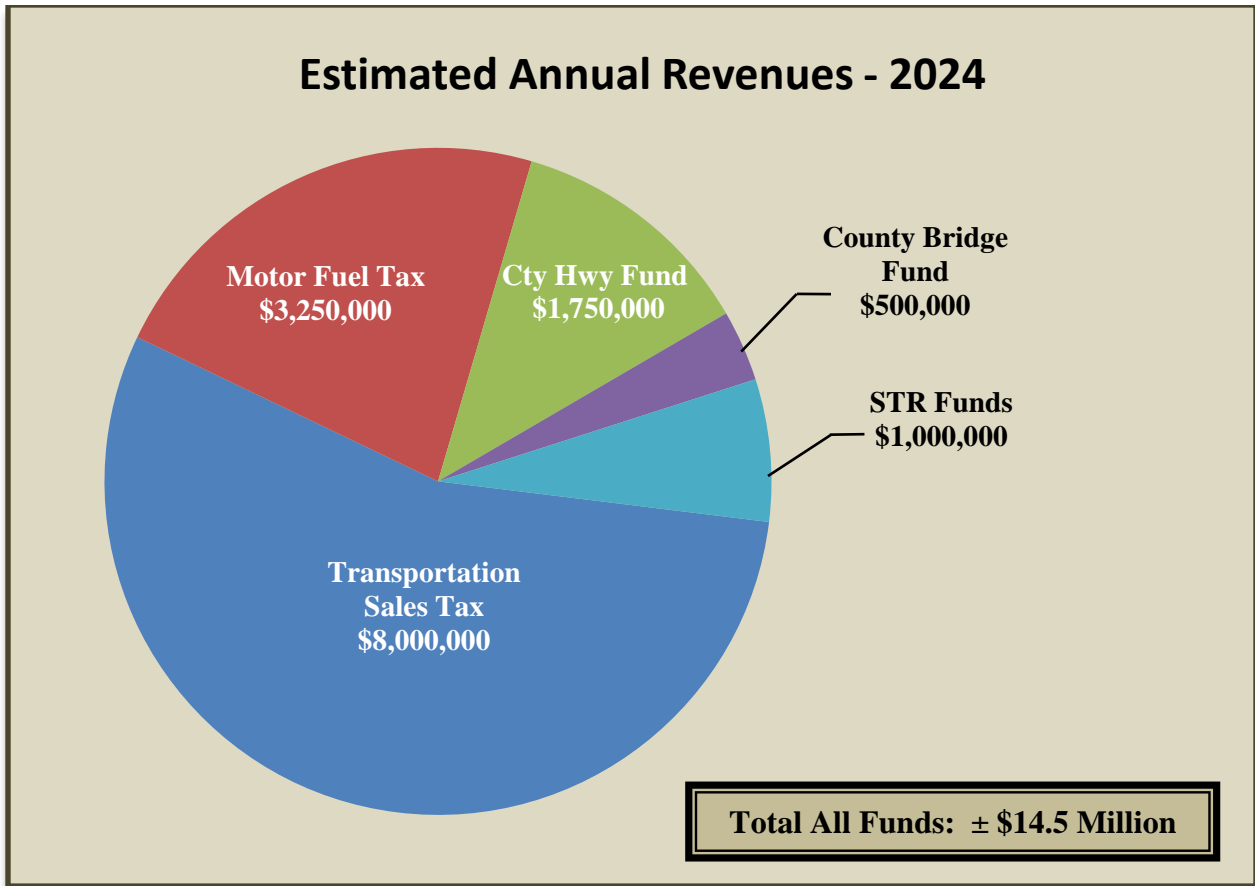

County Highway Fund: The County Highway Fund is a property tax supported fund. Over 85% of all revenues in this fund are derived from property taxes. The fund itself is used for operating expenses for the Kendall County Highway Department. Salaries, maintenance supplies, equipment maintenance, and other operational expenses come out of this fund. No capital-type road or bridge improvements are funded from the County Highway Fund. Even though the historical funding is shown in Exhibit 1 and Exhibit 2, it has been done so only for informational purposes, and has not been included in the Total Capital Funds, since capital improvements have not historically been funded from the County Highway Fund.

County Highway Fund Trends

- *The property tax component of the County Highway Fund had been increasing at a rate of about 4.8% per year during the period from 1998 to 2008 until tax revenues from the Federal Aid Matching Fund were directed to the Highway Fund beginning in 2008. This move was a result of increasing costs for commodities and salaries, as well as the redundancy created by the initiation of the Transportation Sales Tax Fund, which went into effect on July 1, 2007. It also allowed the Board to budget capital equipment costs out of the County Highway Fund, rather than the General Fund. Since 2010, the property tax extension for the Highway Fund has changed little (see Exhibit 2).*

- *Following historical trends, it is now expected that revenues in this fund will stabilize at the new levels, and will only see minor increases for the foreseeable future. A 1.0% per year growth factor is provided, which is a slightly conservative estimate based on the historical growth in this fund, as shown in Exhibit 2.*
- *It is predicted that this fund will continue to provide revenues for all operational expenses of the Highway Department, and will not contribute in any way to future capital highway improvements. It has therefore not been included in the Total Capital Funds in Exhibits 1, 3, & 7.*

As mentioned previously, funds in the County Highway Fund are operational and have not been programmed for capital improvements. Conversely, funds in the County Bridge Fund, Motor Fuel Tax Fund and Transportation Sales Tax Fund will be used for capital improvements and have been estimated in the Capital Program in the attached exhibits

County Bridge Fund: The County Bridge Fund is also a property tax supported fund, receiving nearly all of its revenues from property taxes. Although the fund has increased significantly over the past 25 years, it has actually decreased over the past 10 years, mainly because of the creation of the Transportation Sales Tax, which has bolstered all capital funds for the Highway Department. The Bridge Fund Levy for 2024 is nearly 17% less than in was in 2008.

The cost of bridges has increased dramatically over the past 10 years, far outpacing the increases in pavement construction, and dwarfing the increases in the consumer price index. This fund, along with the Motor Fuel Tax Fund and Federal Aid Matching Fund, has historically been the mainstay for bridge rehabilitation and replacement on the County Highway System. With the elimination of the Federal Aid Matching Fund, the County Bridge Fund and the Transportation Sales Tax Fund will be the main sources of funding for bridges on the County Highway System.

Although Kendall County has only 31 bridges on the County Highway System, the County is frequently petitioned by Townships to participate in bridge projects on the Township System (48 bridges). The County typically helps fund these projects on a 50/50 basis. The annual cost of the joint bridge projects is relatively small, with occasional upward spikes. But a general downward trend in joint bridge projects is expected as township facilities are consumed by municipalities through annexations.

County Bridge Fund Trends

- *This Fund is not expected to grow since the introduction of the Sales Tax for Transportation, which funds can be used just like Bridge Funds for new bridge construction and rehabilitation. Additionally, the restraints of PTELL will undoubtedly limit increases to the fund in future years as the Board struggles to achieve a balanced budget. For the purposes of this study, a 1.0% per year inflator has been calculated for this fund beginning in FY 2024.*

- *The cost of bridges is expected to continue to increase and likely outpace inflation as the cost of structural components increases. This will reduce the “buying power” of this fund.*

Federal Aid Matching Fund: This fund has historically been supported entirely by property taxes. The monies received were used to match federally funded projects, and were also used for other road and bridge improvements on any other federal aid route. The fund has experienced a roller coaster ride over the past 30 years, going from \$384 in revenues in 1993 to \$250,000 in 2003, and increasing to \$350,000 in 2006.

With the introduction of the Sales Tax for Transportation in 2007, there is no longer a need to maintain this fund, since expenditure line items are essentially the same in the two funds. Therefore, the property tax revenues of the FAM Fund, since FY 08, have been re-allocated to the County Highway Fund, and used for operational and maintenance purposes. The yearly levy in this fund has been reduced to zero. This simplifies real estate tax levies and yields more revenues for operational expenses in the Highway Fund as discussed previously.

In fiscal year 2024, Kendall County levied approximately \$1,500,000 in the County Highway Fund, \$500,000 in the County Bridge Fund, bringing the total direct funds (real estate taxes) for highways to \$2 million... exactly the same levy as in 2014 (refer to the Chart on Page 7). In fact, the combined property tax levy for the Highway Department has remained essentially unchanged since 2009.

Federal Aid Matching Fund Trends

- *As stated, the Federal Aid Matching Fund has become a shell fund that is not expected to fund any future improvements. These funding duties will now rest with the Transportation Sales Tax Fund. The F.A.M. Fund has been removed as a source of revenue from all future funding scenarios.*

Transportation Sales Tax Fund: On November 7, 2006, voters in Kendall County approved an increase of 1/2¢ in the local sales tax for transportation purposes. This tax, similar to the Public Safety Sales Tax, was officially implemented July 1, 2007, and the first revenues were received from Illinois Department of Revenue (IDOR) in October 2007. With reductions in other Capital Funds, this revenue stream is instrumental in maintaining the County Highway System at such a high level. The Fund is expected to be used strictly for capital improvements on the County Highway System.

By statute, funds can be used for any transportation purpose for which a county may expend funds under the Illinois Highway Code; meaning that these funds can be used for engineering, land acquisition and construction of highways and bridges. These activities are exactly the same as those funded under the Federal Aid Matching Fund, hence the recommendation to consolidate the Federal Aid Matching Fund into the other real-estate-based funds, namely the County Highway Fund and County Bridge Fund.

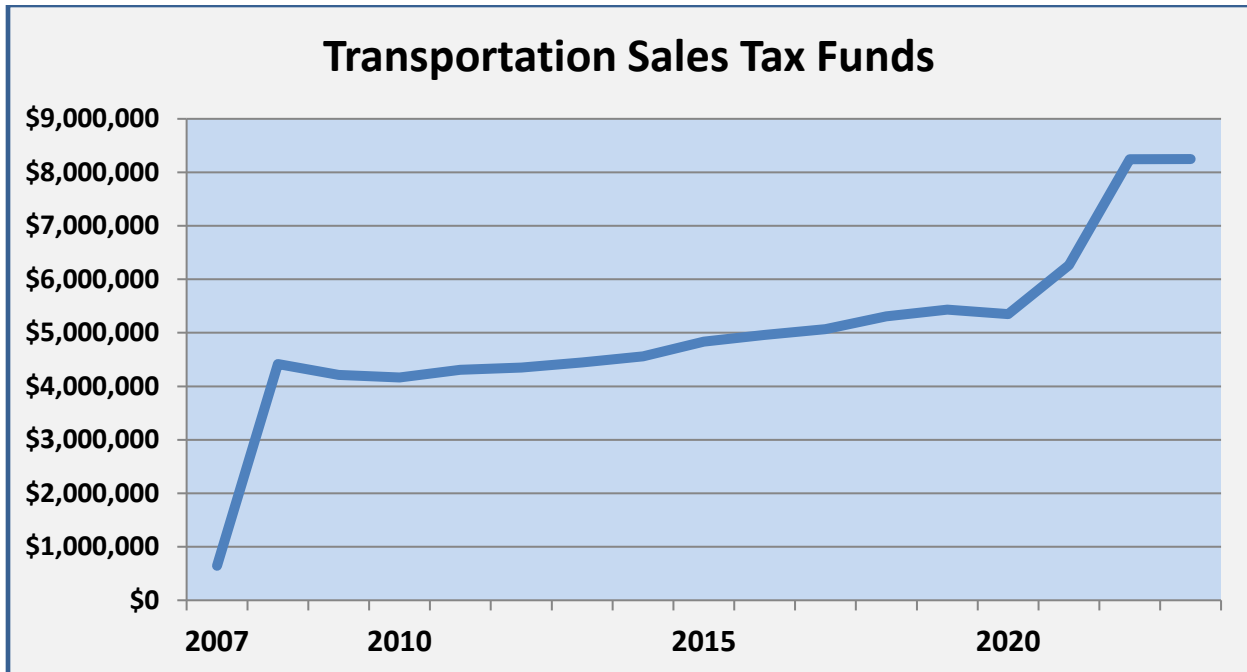

Transportation Sales Tax Trends

- *Annual Transportation Sales Tax Funds were running at a level between \$5 and \$6 million in recent years. With inflation hitting a 40-year high; and the price of gasoline more than double what it had been in 2020, sales tax revenues are soaring. Increases can also be attributed to the recent legislation that required the collection of sales tax for on-line purchases. With new businesses continuing to locate in Oswego, Yorkville, and Plano, sales taxes should remain strong for the foreseeable future. Sales tax receipts are projected to begin at \$8.0 million in the current year, and then grow at a rate of approximately 2% per year over the period of this study.*
- *The Kendall County Board cannot increase the sales tax without another referendum, but they can decrease or eliminate the tax at any time. Because of the enormous need for transportation funding, it is expected and assumed that the 1/2¢ tax rate will not be reduced during the life of this transportation plan.*

Federal Funds: Federal Funds include Surface Transportation-Rural Funds (STR). These federal funds are allocated to Kendall County based on a formula that includes land area, population and mileage. Funds can be used for rural county highways and also for bridge rehabilitation and reconstruction. The funds are actually never in the hands of Kendall County, but are allocated and administered by the Illinois Department of Transportation. Funds can only be spent on projects on the federal aid system and which meet federal eligibility rules.

Due to its continual urbanization, Kendall County has recently been required by federal law to be included in a Metropolitan Planning Organization (MPO). Kendall County is now represented by the Kane/Kendall Council of Mayors, under the umbrella of the Chicago Metropolitan

Agency for Planning (CMAP). CMAP is a result of the consolidation of the Chicago Area Transportation Study (CATS) and the Northeastern Illinois Planning Commission (NIPC). A potential increase in the availability of federal urban funds may come as a result of Kendall's inclusion in the Chicago Metropolitan Area. However, Kendall County will have to compete with other municipal agencies in Kendall and Kane County to garner the funds. Additionally, the pot of urban funds is expected to be small, based on Kendall's relatively small population, compared with other collar counties.

Federal Fund Trends

- *An upward spike in federal funds typically occurs with the passage of the 5-7 year federal transportation bill – most recently with the Infrastructure Investment and Jobs Act (IIJA). Revenues tend to stabilize for the remainder of the bill, and then experience another spike with passage of a subsequent bill. Exhibits 3 & 7 reflect these spikes and plateaus over the next 20 years.*
- *No significant increases in federal funds are projected under this funding plan, even though more urban revenues may become available. It is expected that these additional urban funds will not provide a consistent source of revenue for the County, but will instead be an occasional earmark for specific projects.*

Needed Highway / Bridge Improvements

Anticipated improvements on the County Highway System can be categorized in three ways: Intersection Improvements; Capacity Improvements; and Bridge Improvements.

Intersection Improvements: As the volume of vehicles entering an intersection increases, the need for turning lanes, traffic signals or roundabouts increases. Turning lanes and signals generally provide a greater level of safety for the motorists, while roundabouts can create an even greater level of safety and eliminate maintenance and electrical costs that are needed for traffic signals. Capacity of the intersection generally increases with the implementation of these improvements.

The cost of an intersection improvement can vary greatly depending on many factors. For the purposes of this study, historical costs of 3-leg and 4-leg intersections were used as a baseline, with other adjustment factors assigned where needed.

Capacity Improvements: For the purposes of this study, capacity improvements are defined as “add lane” improvements. In general, 2-lane roadways and bridges can accommodate a limited amount of traffic. As roadways approach 15,000 vehicles per day, consideration should be given to a capacity improvement. Capacity improvements are identified on several county highways where impending growth will dictate the need for additional lanes.

Bridge Improvements: These improvements are self-explanatory. Bridges that have reached the end of their useful life, or bridges that require capacity improvements must either be rehabilitated or replaced.

A list of anticipated improvements required over the next 20 years has been included in this funding plan as Exhibit 5. These projects are also represented pictorially on Exhibit 6.

It is important to note that this plan assumes financial cooperation of future developments in the capacity improvements of several roadways, including Little Rock Road, Galena Road, Grove Road, Plainfield Road, Ridge Road and Caton Farm Road. These funds are anticipated through county/municipal cooperation during the annexation phase, and can generally be described as development fees. Although not an “impact fee” in the legal sense of the word, these development fees have been discussed at length with the municipalities in Kendall County. It is the general belief that municipalities will begin to require developers to set aside funds for the future improvement of county transportation corridors that will affect their developments, or they will simply require developers to actually construct the improvements to the County Highway System.

To this end, significant progress has been made with several municipalities in Kendall County. The Village of Oswego, City of Yorkville, and City of Plano have already adopted policies to collect transportation development fees on behalf of Kendall County. As three of the larger contributors to new residential developments in the County, this should make a significant impact in the ability to improve County Highways as development occurs. Minooka, Joliet, and Plainfield are also recognizing the need to improve County corridors as part of the normal development cycle. But since collection of these fees may frequently be at building permit time, revenues will ride the cycles of boom and bust in the real estate market.

Obviously, no one can know, with certainty, to what degree Kendall County will have to participate in the listed projects. Projects along state routes, which are initiated by the state, are frequently paid for by the state. On the other hand, projects initiated by a local agency are frequently paid for, to a larger degree, by the local agency. There is also a significant degree of uncertainty with the level of funding to be provided by municipal developments. Kendall County is currently working with municipal agencies to address some of these municipal issues. In general it is assumed that underestimated costs on one project may well be balanced by overestimated costs on another project.

Maintenance & Pavement Preservation

Capital improvements to the county road and bridge system cannot simply be built and forgotten. Ongoing rehabilitation and maintenance is required each year to keep the system operating at its greatest efficiency. The cost of “maintaining” the system is included in capital costs that are summarized in Exhibit 7.

The estimated life of a flexible pavement, before it needs some type of maintenance or rehabilitation, is about 15 years. In Kendall’s case, with approximately 280 lane-miles of pavement, about 20 lane-miles (10 centerline miles) should be rehabilitated each year just to keep the system operational. The approximate cost of rehabilitating 20 lane-miles of pavement is about \$3,000,000 in 2024 dollars. It is expected that these costs will grow at some inflationary rate over the next 20 years. For the purposes of this study, an annual increase of 2.0% has been

assumed. This increase is approximately the same as the 15-year historical increase in the Consumer Price Index (1.92%), shown in Exhibit 4.

Additionally, County Highway System mileage is expected to increase from 280 lane miles currently to approximately 400 lane miles in 2044 if all improvements identified in Exhibit 5 are completed. Annualized over this 20-year period, it means that the highway system will grow an average of 2% per year. Therefore, the assumption of 2.0% annual increase in maintenance cost may be slightly underestimated for the purposes of this study.

Assumptions

As with any long term study, many assumptions must be made to reach a congruent conclusion. This study is no different. But in an effort to provide greater insight to the conclusions drawn in the final analysis, a list of some of the major assumptions is provided here.

- Kendall County will continue to maintain its highway and bridge system, without adding or deleting significant facilities from other agencies.
- Kendall County will grow at a rate that predicted by the Chicago Metropolitan Agency for Planning (CMAP), i.e., will grow to a population of 200,000 by 2040.
- Motor Fuel Taxes will continue to increase due to the projected increases in registered vehicles in the county. This also assumes that technological advances in transportation will not cause a fundamental redistribution of these funds.
- The Kendall County Board will continue to levy property taxes for the County Highway and County Bridge Funds, after consolidating revenues from the Federal Aid Matching Fund into these funds in FY 2008. Increases will not be less than an average of 1.0% in the Highway Fund over the period of this study.
- Federal funds will continue to be made available to Kendall County through the State of Illinois for improvements on the federal aid network.
- Inflation for road and bridge construction will not exceed an average of 2.0% over the period of this study. Inflation has averaged approximately 1.92% per year over the past 15 years in the Midwest Urban Area (see Exhibit 4).
- No new revenue sources will become available, other than the ones under consideration as part of this study.
- Developers will pay for new intersections on county highways that will serve their developments.
- Municipal developers will pay a significant share of the cost of constructing a 4-lane WIKADUKE Trail, and will assist in the financing of other capacity improvements through the collection of development fees.
- Kendall County will be on the receiving end of significant federal funding or other local funding for major projects identified in the long range plan.
- The life cycle costs of maintaining flexible pavements will not change dramatically due to technological advances, or for other reasons.
- The new Transportation Sales Tax, implemented in 2007, will stay at ½ ¢ for the length of this study.

Analysis

Referring to Exhibit 7, Kendall County is now receiving significant Transportation Sales Tax Revenues. It is expected that revenues from this tax will total approximately \$8 million in FY 2024. Revenues from the Sales Tax have had a significant and dramatic impact on the ability of Kendall County to provide improvements to the County Highway System, by more than doubling available funds for capital improvements. An annual inflator of 2% has been assumed for these revenues. It is certainly possible and probable that the Transportation Sales Tax will grow at an annual rate greater than 2% as the economy continues to gain strength; but a conservative estimate of just 2% is being assumed for the purpose of this study.

With the Sales Tax for Transportation in place, the total capital program for Kendall County will start near \$13 million per year in 2024, and will grow to over \$18 million per year in 2044. This is a rather nominal increase in the program, considering that inflation will likely exceed the increase in revenues to the program. Still, the combined capital revenues are very dependable, and should help to address the transportation needs of this County for the foreseeable future. It will also allow tremendous flexibility in the program by allowing the County to partner with other transportation agencies to make system-wide improvements.

The single biggest, and arguably most important, transportation project in Kendall County's history - that being construction of the Eldamain Road Extension over the Fox River – was completed in 2023. This will allow the County to turn its attention to the Ridge Road Corridor (WIKADUKE Trail). Significant increases in traffic have been observed in this corridor over the past 10 years. More is anticipated in the future. Some funding for projects in this corridor has already been committed by KKCOM; and the County will continue to pursue all available Federal and State grants for this important corridor.

The list of needed projects (Exhibit 5) also assumes that the County will receive financial participation from other agencies, collection of fees from developments within corporate limits, and federal and state funding on key components of the plan.

Averaged over 20 years, it is estimated that revenues and expenditures will be about the same, with an approximate \$11 million deficit at the end of this plan. However, so many uncertainties exist in the compilation of a long-range transportation plan, that this deficit could easily be viewed as relatively insignificant... considering it is only about 5% of the total cost of the Plan. Nevertheless, it is important that the Kendall County Board remain vigilant in awareness of the need to continue pursuit of funding for needed transportation projects.

Conclusion

Based on the information contained in this study, it is expected that existing revenue streams, including the new Sales Tax for Transportation, should address the majority of vehicular transportation needs over the life of this study, assuming Kendall County continues to be successful in collecting Transportation Development Fees for new residential developments in the County, as well as continuing to receive state and federal assistance on specific projects.

The funding plan does not currently include a public transit component. Therefore, intermodal additions to the plan will require a complete reevaluation of the capital program and its funding components.

If new highways and bridges are added to the current County Highway System, or if intermodal additions are considered, the County may want to consider additional revenue streams to fund these additional components. Sources to consider have been identified in *Transportation Fiscal Impacts of Growth in Kendall County*, prepared by Robinson Engineering Ltd. on July 6, 2004.

KENDALL COUNTY

Historical Highway Department Funding (Annual)

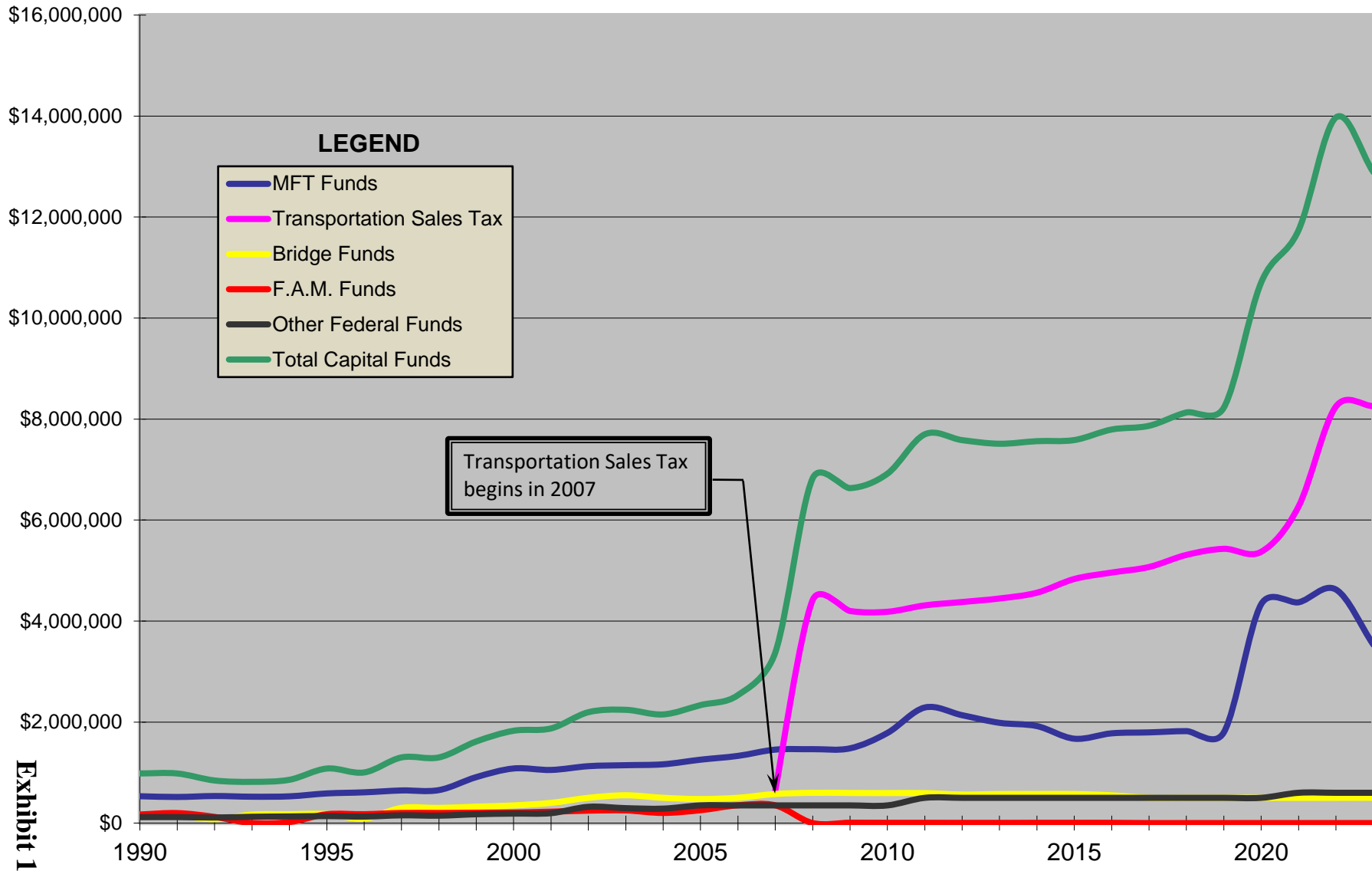

Exhibit 1

Kendall County Highway Department Historical Tax Levy Data

Year	County Highway Fund		County Bridge Fund		F.A.M. Fund		Total
	Rate	Extension	Rate	Extension	Rate	Extension	Extension
1987	0.1000	\$475,732	0.0500	\$160,572	0.0500	\$160,573	\$796,877
1988	0.0992	\$485,397	0.0496	\$167,667	0.0496	\$167,667	\$820,731
1989	0.0958	\$475,972	0.0444	\$154,861	0.0444	\$154,861	\$785,694
1990	0.0849	\$491,599	0.0412	\$164,294	0.0425	\$169,461	\$825,354
1991	0.0774	\$494,332	0.0332	\$148,521	0.0442	\$197,727	\$840,580
1992	0.0295	\$285,266	0.0148	\$76,057	0.0238	\$122,015	\$483,338
1993	0.0757	\$577,168	0.0303	\$168,947	0.0000	\$384	\$746,499
1994	0.0683	\$562,533	0.0295	\$175,932	0.0034	\$20,074	\$758,539
1995	0.0882	\$559,609	0.0284	\$180,098	0.0276	\$174,655	\$914,362
1996	0.0792	\$545,028	0.0131	\$90,150	0.0254	\$175,483	\$810,661
1997	0.0740	\$560,223	0.0397	\$300,365	0.0265	\$200,496	\$1,061,084
1998	0.0670	\$550,693	0.0365	\$300,004	0.0244	\$200,551	\$1,051,248
1999	0.0631	\$559,431	0.0367	\$325,374	0.0232	\$205,686	\$1,090,491
2000	0.0605	\$580,306	0.0364	\$349,524	0.0216	\$209,715	\$1,139,545
2001	0.0525	\$610,161	0.0364	\$400,516	0.0216	\$225,290	\$1,235,967
2002	0.0576	\$678,103	0.0426	\$500,336	0.0208	\$246,048	\$1,424,487
2003	0.0488	\$680,060	0.0395	\$550,458	0.0179	\$250,842	\$1,481,360
2004	0.0400	\$639,500	0.0313	\$500,408	0.0126	\$201,442	\$1,341,350
2005	0.0352	\$641,311	0.0251	\$475,517	0.0140	\$255,067	\$1,371,895
2006	0.0357	\$761,330	0.0235	\$501,155	0.0165	\$351,875	\$1,614,360
2007	0.0313	\$801,910	0.0225	\$576,453	0.0137	\$350,996	\$1,729,359
2008*	0.0411	\$1,251,316	0.0197	\$599,779	0.0000	\$0	\$1,851,095
2009	0.0427	\$1,399,509	0.0182	\$596,512	0.0003	\$6,555	\$2,002,576
2010	0.0436	\$1,465,512	0.0177	\$594,281	0.0002	\$5,048	\$2,064,841
2011	0.0462	\$1,465,357	0.0187	\$593,883	0.0002	\$5,076	\$2,064,316
2012	0.0509	\$1,485,191	0.0194	\$565,078	0.0002	\$4,084	\$2,054,353
2013	0.0552	\$1,474,998	0.0215	\$574,886	0.0002	\$4,005	\$2,053,889
2014	0.0584	\$1,475,080	0.0228	\$575,074	0.0002	\$5,053	\$2,055,207
2015	0.0583	\$1,475,151	0.0228	\$575,243	0.0002	\$5,057	\$2,055,451
2016	0.0569	\$1,500,055	0.0209	\$550,152	0.0000	\$5,013	\$2,055,220
2017	0.0528	\$1,500,104	0.0176	\$500,035	0.0000	\$0	\$2,000,139
2018	0.0495	\$1,499,906	0.0165	\$499,868	0.0000	\$0	\$1,999,774
2019	0.0465	\$1,500,027	0.0155	\$500,224	0.0000	\$0	\$2,000,251
2020	0.0437	\$1,500,187	0.0146	\$500,177	0.0000	\$0	\$2,000,364
2021	0.04185	\$1,499,895	0.01395	\$500,085	0.00000	\$0	\$1,999,980
2022	0.03968	\$1,500,333	0.01323	\$500,237	0.00000	\$0	\$2,000,570
2023	0.03636	\$1,505,641	0.01212	\$501,880	0.00000	\$0	\$2,007,521
2024†	0.03260	\$1,510,574	0.01087	\$503,679	0.00000	\$0	\$2,014,253

* Federal Aid Matching Revenues are rolled into County Highway Revenues

Capital Expenditures were then taken out of Highway Fund instead of General Fund

† Capital Expenditures now taken out of Transportation Sales Tax Fund

1987 to 2024 Historical Trend in Highway Funding

Fund	Tax Rate Reduction (%)	Ave. Annual Increase in Funds
County Highway Fund	67%	3.17%
County Bridge Fund	78%	3.14%
Total Extension for Highway Department	71%	2.54%

KENDALL COUNTY

Estimated Annual Funding Levels for Capital Improvements w/ No New Funds

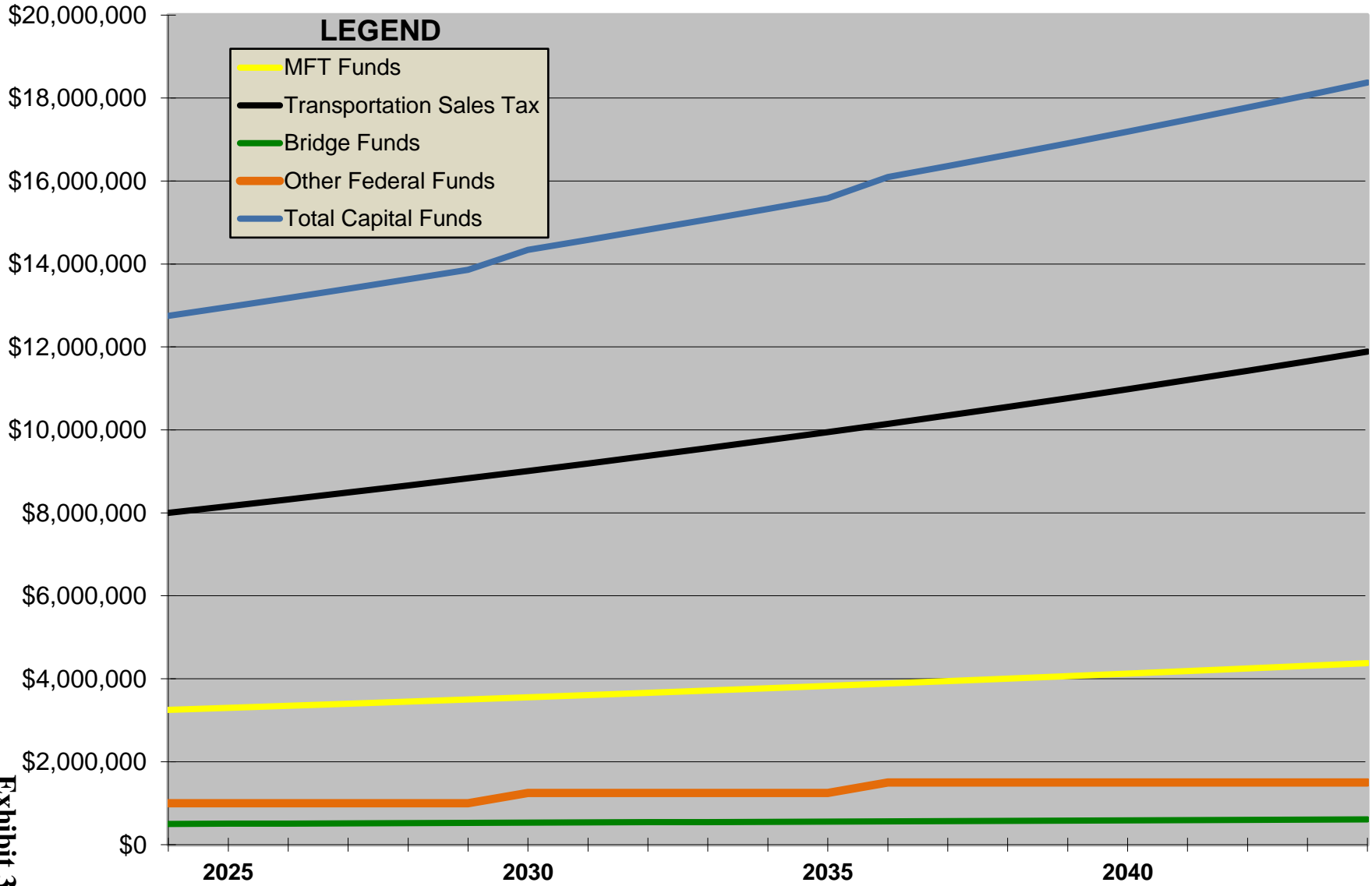

**CPI for All Urban Consumers (CPI-U)
Original Data Value**

Series CUURS23ASA0

Id: CUUSS23ASA0

Not Seasonally Adjusted

Series All items in Chicago-Naperville-Elgin, IL-

Title: IN-WI, all urban consumers

Area: Midwest

Item: All items

Base 1982-84=100

Period:

Years: 2008 to 2023

Year	Jan	Feb	Mar	Apr	May	Jun	Jul	Aug	Sep	Oct	Nov	Dec	Annual
2008	208.8	209.5	211.5	212.7	214.9	215.7	217.5	216.0	215.5	213.4	209.1	206.0	212.5
2009	207.6	207.4	207.5	207.9	209.8	211.0	210.9	211.4	211.3	211.7	212.2	211.2	210.0
2010	212.1	212.5	213.0	212.9	213.0	212.2	212.5	212.8	213.3	213.3	213.1	213.8	212.9
2011	215.2	216.2	217.9	218.8	220.1	220.2	219.3	219.7	220.0	219.6	219.2	218.2	218.7
2012	219.6	219.6	222.4	222.4	222.3	222.1	221.6	223.0	223.6	223.2	222.4	221.8	222.0
2013	222.3	224.7	224.4	224.5	225.6	225.9	225.4	225.5	225.2	224.4	223.7	223.0	224.5
2014	225.0	226.2	228.8	229.8	229.6	230.5	229.6	229.8	229.8	229.0	227.2	226.3	228.5
2015	225.9	225.8	227.4	227.7	228.5	228.8	228.6	229.5	228.8	228.6	227.6	226.3	227.8
2016	228.0	227.4	227.8	229.2	229.2	230.3	228.5	229.0	230.3	230.5	231.0	230.5	229.3
2017	232.2	232.5	232.2	233.1	233.4	233.4	233.5	234.2	235.2	234.2	235.2	234.3	233.6
2018	236.3	236.3	236.4	237.9	238.9	238.5	237.9	238.1	239.0	238.9	237.5	236.8	237.7
2019	238.2	239.7	240.0	239.7	241.8	240.8	241.6	242.0	242.4	243.2	242.7	242.1	241.2
2020	244.4	244.4	242.7	240.4	242.7	243.5	244.0	244.3	245.7	245.6	244.6	244.2	243.9
2021	246.0	247.4	249.0	251.5	253.9	255.0	255.9	256.1	256.9	258.6	259.3	260.4	254.2
2022	262.7	264.8	268.4	269.6	274.3	277.8	277.3	277.5	278.0	278.4	276.9	274.6	273.4
2023	277.0	278.0	280.3	282.4	283.4	283.6	283.5	284.0	284.4	285.2	283.9	283.8	282.5

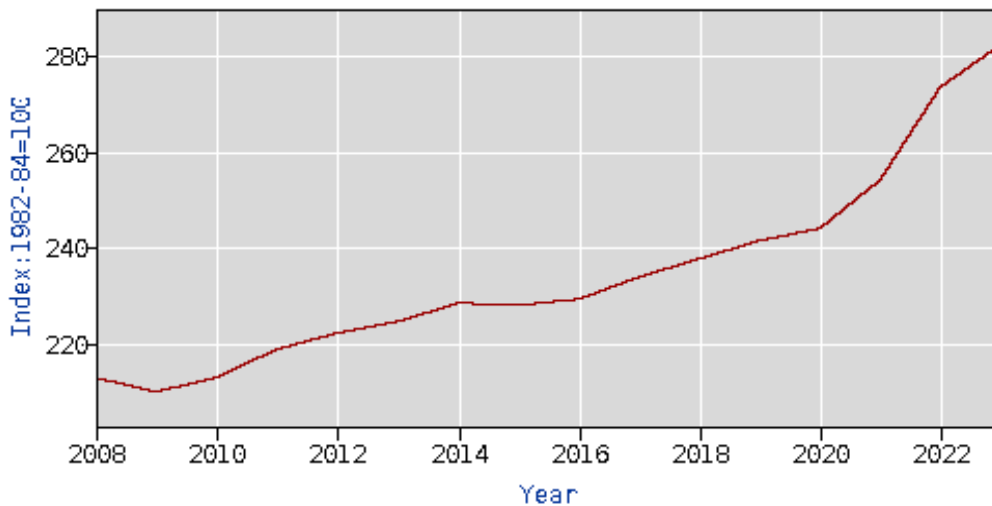

Average Annual Increase in CPI from 2008 to 2023: 1.92%

2024-2044 ANTICIPATED CAPITAL IMPROVEMENTS
Kendall County Highways

Highway	2024-2044 Anticipated Capital Improvements	Estimated Total Cost (County Share)
<i>Cannonball Trail</i>	<i>Intersection Improvement at Bristol Ridge Rd.</i>	\$750,000
	<i>Urban 3-Lane Section - Rte 47 to Galena Rd.</i>	\$7,500,000
<i>Caton Farm Road</i>	<i>Bridge Replacement East of Ashley Rd.</i>	\$1,000,000
	<i>Intersection Improvement at Grove Rd.</i>	\$1,000,000
	<i>Bridge Replacement east of Grove Rd.</i>	\$1,800,000
	<i>Bridge Replacement east of Schlapp Rd.</i>	\$2,000,000
	<i>Intersection Improvement at Ridge Rd.</i>	\$1,500,000
	<i>Urban 5-Lane Section from Schlapp Rd. to Ridge Rd.</i>	\$7,500,000
<i>Eldamain Road</i>	<i>Miscellaneous Intersection Improvements</i>	\$3,000,000
	<i>Contract C - Highpoint Rd to Walker Rd</i>	\$8,000,000
<i>Fox Road</i>	<i>Box Culvert Replacement at Pavillion Rd.</i>	\$500,000
	<i>Realignment at Illinois Railways & Eldamain Rd.</i>	\$4,000,000
<i>Fox River Drive</i>	<i>Intersection improvement at Crimmins Rd.</i>	\$2,000,000
	<i>Reconstruct Crimmins Rd. as FRD Extension</i>	\$5,000,000
	<i>Reconstruct N Johnson St. in Newark</i>	\$2,500,000
	<i>Rehabilitate Bridge over Fox River</i>	\$6,200,000
<i>Galena Road</i>	<i>Intersection Improvement at Little Rock Rd.</i>	\$1,250,000
	<i>Intersection Improvement at Rock Creek Rd.</i>	\$500,000
	<i>Intersection Improvement at Rte. 47 w/ Bridge</i>	\$1,000,000
	<i>Intersection Improvement at Cannonball w/ realignment</i>	\$4,000,000
	<i>Urban 3-Lane Section from Rte. 47 to Orchard</i>	\$18,000,000
<i>Grove Road</i>	<i>Intersection Improvement at Rte. 126</i>	\$500,000
	<i>Intersection Improvement at U.S. Route 52</i>	\$1,000,000
	<i>Intersection Improvement at Reservation w/ Realignment</i>	\$2,000,000
<i>Joliet Road</i>	<i>Bridge Replacement at Valley Run Creek</i>	\$1,500,000
<i>Little Rock Road</i>	<i>Intersection Improvement at Abe Street</i>	\$1,000,000
	<i>Intersection Improvement at Center Street</i>	\$1,000,000
	<i>Intersection Improvement at Miller Rd.</i>	\$1,000,000
	<i>Urban 3-lane Rte. 34 to Miller Rd.</i>	\$15,000,000
<i>Millbrook Road</i>	<i>Intersection Improvement at Rte 71 w/ Realignment</i>	\$2,000,000
	<i>Intersection at Fox River Drive & Whitfield Road</i>	\$2,000,000

* County Share reduced by developer donations

2024-2044 ANTICIPATED CAPITAL IMPROVEMENTS
Kendall County Highways

Highway	2024-2044 Anticipated Capital Improvements	Estimated Total Cost (County Share)
<i>Millington Road</i>	<i>Intersection Improvement at Rogers Rd.</i>	\$1,000,000
	<i>Intersection Improvement at Millhurst Rd.</i>	\$1,000,000
	<i>Extension to Duvick Road</i>	\$3,500,000
<i>Orchard Road</i>	<i>Intersection Improvement at U.S. Route 30</i>	\$1,000,000
	<i>Bridge Widening over Fox River</i>	\$7,000,000
	<i>Intersection Improvement at Tuscany Tr.</i>	\$500,000
	<i>Minkler/ Collins Connector - Intersections</i>	\$2,500,000
<i>Plainfield Road</i>	<i>Intersection Improvement at Templeton Dr.</i>	\$500,000
	<i>Intersection Improvement at Collins Rd.</i>	\$1,000,000
	<i>Intersection Improvement at Douglas Rd.</i>	\$1,000,000
	<i>Urban 3-Lane Section Linden St. to Ridge Rd.</i>	\$12,000,000
<i>Platteville Road</i>	<i>Replace structure 047-3141</i>	\$1,000,000
<i>Ridge Road</i>	<i>Construct 4-Lane Widening - Holt Rd to Black Rd</i>	\$25,000,000
	<i>Construct 4-Lane Widening - CFR to Plainfield Rd</i>	\$28,000,000
	<i>Signalization of multiple other intersections</i>	\$2,500,000
<i>Rock Creek Road</i>	<i>Transfer to City of Plano before 2044</i>	
<i>Van Emmon Road</i>	<i>Rehabilitation & JT from Rte. 47 to City Park</i>	\$1,500,000
<i>Walker Road</i>	<i>Realignment east of Fox River Drive</i>	\$3,000,000
	<i>Intersection Improvement at Lisbon Rd</i>	\$2,000,000

* County Share reduced by developer donations

Totals: \$200,000,000

HIGHWAY MAP

KENDALL COUNTY

PROPOSED CAPITAL IMPROVEMENTS

2024 - 2044

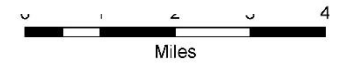
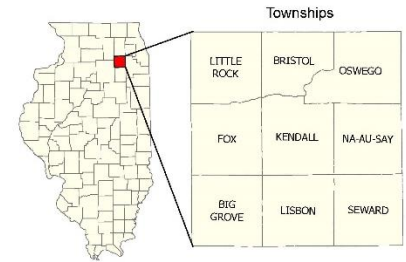

- Adjacent County
 - County
 - Interstate
 - State & Federal
 - Bituminous
 - - - Gravel
 - - - Dirt
 - Local
 - Political Townships
 - State Park
 - County Forest Preserve
 - Aurora
 - Joliet
 - Lisbon
 - Millbrook
 - Millington
 - Minooka
 - Montgomery
 - Newark
 - Oswego
 - Plainfield
 - Plano
 - Plattville
 - Sandwich
 - Yorkville
-
- Intersection Improvement
 - ⊠ Bridge Replacement or Rehab
 - Significant Roadway Improvement
 - Roadway Capacity Improvement

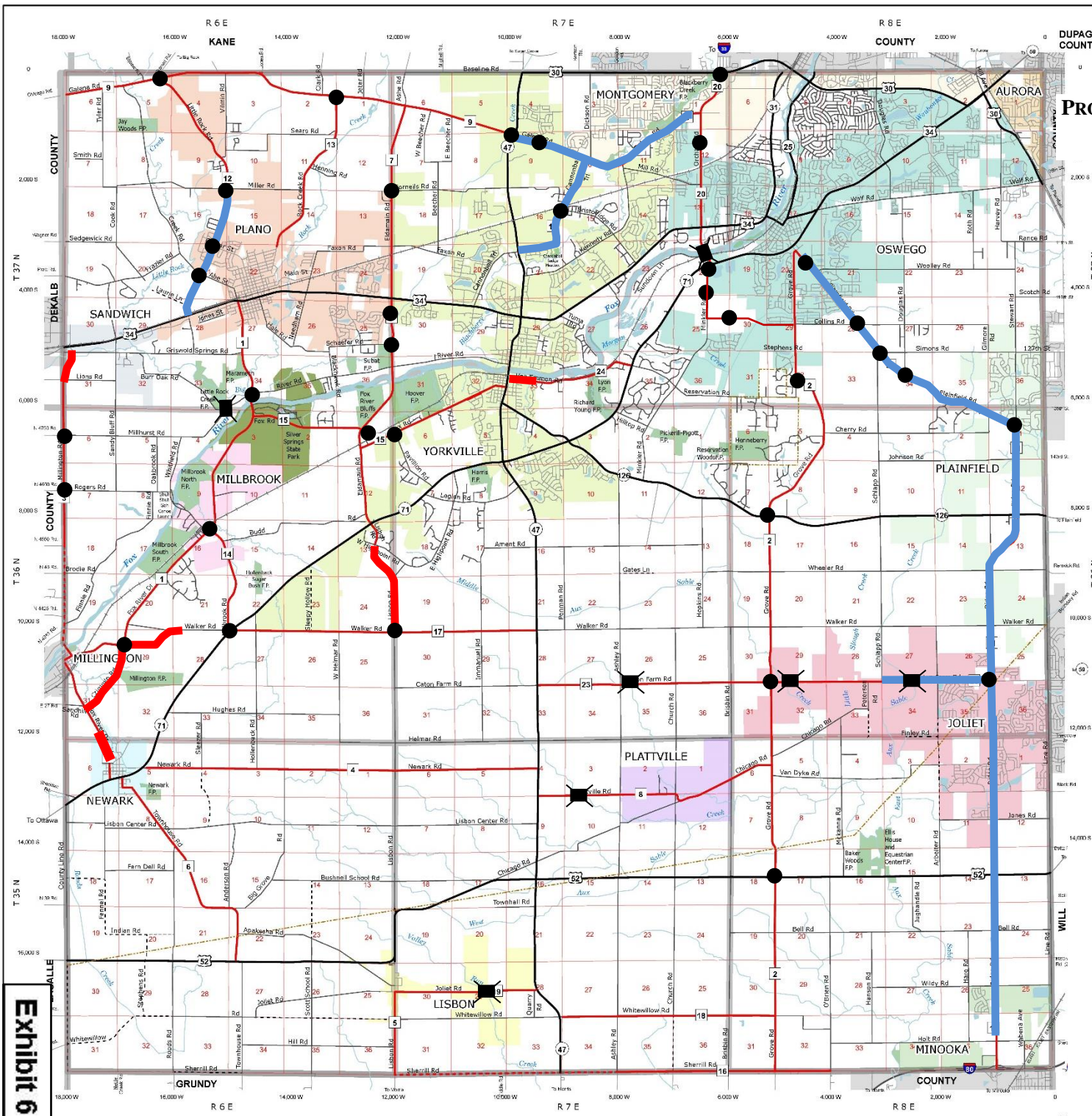

Exhibit 6

NO
 1
 2
 3
 4
 5
 6
 7
 8
 9
 10
 11
 12
 13
 14
 15
 16
 17
 18
 19
 20
 21
 22
 23
 24
 25
 26
 27
 28
 29
 30
 31
 32
 33
 34
 35
 36
 37
 38
 39
 40
 41
 42
 43
 44
 45
 46
 47
 48
 49
 50
 51
 52
 53
 54
 55
 56
 57
 58
 59
 60
 61
 62
 63
 64
 65
 66
 67
 68
 69
 70
 71
 72
 73
 74
 75
 76
 77
 78
 79
 80
 81
 82
 83
 84
 85
 86
 87
 88
 89
 90
 91
 92
 93
 94
 95
 96
 97
 98
 99
 100

FINANCIAL ANALYSIS OF 2024-2044 TRANSPORTATION PLAN
Kendall County

Year	Estimated Revenues (\$000's)					Averaged Expenditures (\$000's)			Surplus/Deficit (\$000's)
	MFT	Bridge	Federal	Sales Tax	Total	Capital †	Maintenance ‡	Total	
2024	3,250	500	1,000	8,000	12,750	10,000	3,000	13,000	-250
2025	3,299	505	1000	8,160	12,964	10,200	3,060	13,260	-296
2026	3,348	510	1000	8,323	13,181	10,404	3,121	13,525	-344
2027	3,398	515	1000	8,490	13,403	10,612	3,184	13,796	-392
2028	3,449	520	1000	8,659	13,629	10,824	3,247	14,072	-442
2029	3,501	526	1,000	8,833	13,859	11,041	3,312	14,353	-494
2030	3,554	531	1,250	9,009	14,344	11,262	3,378	14,640	-296
2031	3,607	536	1,250	9,189	14,583	11,487	3,446	14,933	-350
2032	3,661	541	1,250	9,373	14,826	11,717	3,515	15,232	-406
2033	3,716	547	1,250	9,561	15,074	11,951	3,585	15,536	-463
2034	3,772	552	1,250	9,752	15,326	12,190	3,657	15,847	-521
2035	3,828	558	1,250	9,947	15,583	12,434	3,730	16,164	-581
2036	3,886	563	1,500	10,146	16,095	12,682	3,805	16,487	-392
2037	3,944	569	1,500	10,349	16,362	12,936	3,881	16,817	-455
2038	4,003	575	1,500	10,556	16,634	13,195	3,958	17,153	-519
2039	4,063	580	1,500	10,767	16,911	13,459	4,038	17,496	-586
2040	4,124	586	1,500	10,982	17,193	13,728	4,118	17,846	-653
2041	4,186	592	1,500	11,202	17,480	14,002	4,201	18,203	-723
2042	4,249	598	1,500	11,426	17,773	14,282	4,285	18,567	-794
2043	4,313	604	1,500	11,654	18,071	14,568	4,370	18,939	-867
2044	4,377	610	1,500	11,888	18,375	14,859	4,458	19,317	-942
Totals:	79,529	11,620	27,000	206,267	324,415	257,833	77,350	335,183	-10,768

† \$200 Million Capital Improvement Costs (Exhibit 5) are averaged over 20 years using 2024 dollars, and then a 2% rate of inflation is applied.

‡ Annual maintenance (rehabilitation) costs begin at \$3,000,000 and increase at an estimated rate of 2.0% per year.

No operational costs for the Kendall County Highway Department are included in this Exhibit (see page 8).

PROJECTED FUTURE TRAFFIC
Kendall County Highways

County Highway	I.D.O.T. Key Route	Highway No.	Length (Miles)	2019 ADT		2044 ADT	
				Loc A	Loc B	Loc A	Loc B
Cannonball Trail	1262	10	2.44	3,200	3,050	6,400	6,100
Caton Farm Road	300	23	4.25	1,650	1,650	3,500	3,500
			4.00	2,150	5,700	4,500	12,000
Chicago Road	283	8	1.79	350	300	1,000	1,000
Collins Road	2514	20	1.63	0	0	5,000	6,000
Eldamain Road	4000	7	0.42	0	0	1,500	1,500
			4.34	750	4,550	5,000	10,000
			3.52	7,900	7,300	15,000	14,000
Fox River Drive (South)	171	1	2.53	1,200	850	3,000	2,500
Fox River Drive	276	1	5.98	1,000	2,400	2,500	5,000
Fox River Drive	276	1	2.16	4,750	3,150	9,000	5,500
Fox Road	277	15	4.14	2,700	3,500	5,000	6,500
Galena Road	177	9	1.75	7,100	6,950	10,000	10,000
			6.61	2,750	6,400	7,500	11,000
			3.78	7,000	11,800	12,000	18,000
Granart Road	168		0.08	6,100		11,000	
Grove Road (North)	284 2507	2	5.40	1,250	4,300	5,000	10,000
Grove Road (South)	1259	2	7.06	1,000	2,450	3,000	5,000
			3.01	2,850	2,800	5,000	5,500
Joliet Road	281	19	2.55	500	675	1,000	2,000
Lisbon Road	282	5	1.50	900	900	1,500	1,500
Little Rock Road	168/6475/1256	12	1.40	3,700	3,550	7,500	7,000
			3.60	3,300	1,900	7,000	4,000
Millbrook Road	1263	14	2.05	2,600	3,250	5,000	6,000
Millington Road	171	3	2.86	1,550	650	3,000	2,000
Minkler Road	3792	20	0.93	3,850	3,850	9,000	10,000
Newark Road	279	4	7.16	900	675	2,500	2,000
Orchard Road	3792	20	3.63	13,900	23,200	25,000	35,000
Plainfield Road	1258	22	5.27	7,450	13,100	15,000	25,000
Plattville Road	283	8	2.68	300	300	750	1,000
Ridge Road	285	11	3.50	24,700	10,300	35,000	20,000
			3.50	7,550	9,200	15,000	18,000
			3.24	8,800	8,800	15,000	15,000
			1.64	13,000	13,000	25,000	25,000
Rock Creek Road	1261	13	3.20	2,350	3,200	4,000	5,000
Sheridan Road	1271		0.19	1,250	1,250	2,500	2,500
Sherrill Road	?	16	3.86	375	450	1,000	1,500
Townhouse Road	1255	6	4.43	425	1,150	1,000	2,000
Van Emmon Road	280	24	1.85	4,000	4,000	7,500	7,500
Walker Road	1260	17	5.51	1,600	1,350	4,000	4,000
Whitewillow Road	18	18	3.89	275	200	750	600

DESIGN STANDARDS / GEOMETRIC FEATURES

Kendall County Highways

Design Standards for Kendall County Highways and Bridges shall include, but are not limited to, the following publications:

- *Bureau of Design and Environment Manual*
Illinois Department of Transportation (IDOT)
- *Bureau of Local Roads and Streets Manual*
Illinois Department of Transportation (IDOT)
- *A Policy on Geometric Design of Highways and Streets*
American Association of State Highway and Transportation Officials (AASHTO)
- *Manual on Uniform Traffic Control Devices for Streets and Highways*
U.S. Department of Transportation, Federal Highway Administration (FHWA)

Exhibits 9a – 9e provide examples of the geometric features associated with different levels of traffic and different classifications of highways.

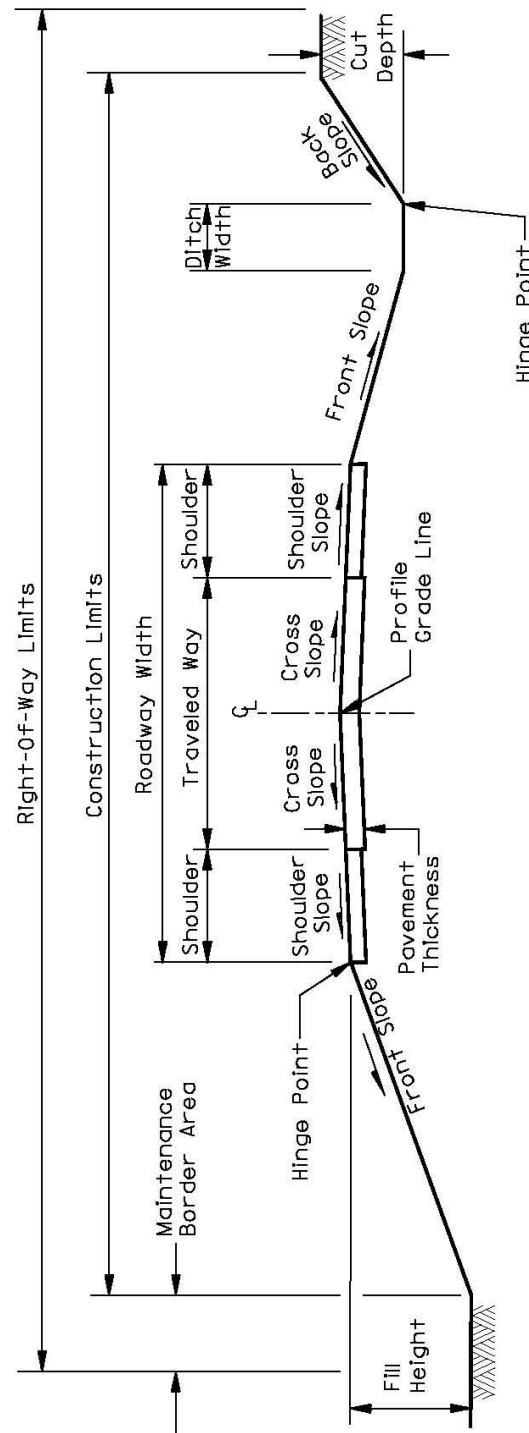

TYPICAL CROSS SECTION FOR RURAL TWO-LANE HIGHWAYS

Figure 31-1A

- Travel lanes are typically 12' to 14' in width
- Parking lanes are 8' and variable
- CC&G is normally B.6-24. Sidewalk locations may vary
- Right-of-way limits vary from 60' to 100'
- This section is applicable for urban highways with AADT \leq 15,000

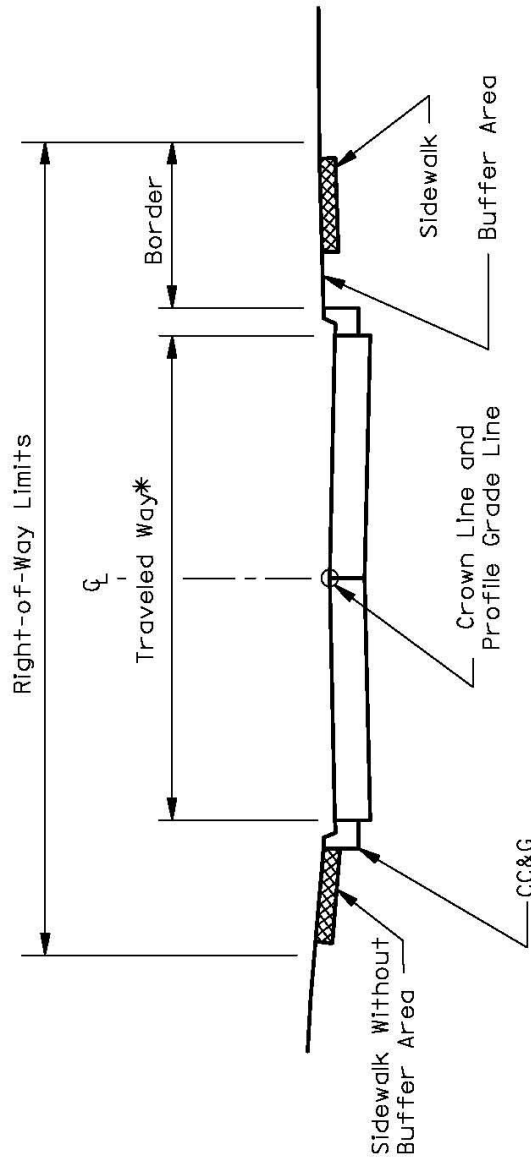

* The traveled way may have two-way or one-way traffic.

TYPICAL CROSS SECTION FOR URBAN STREETS
(Two-Lanes without Parking)

Figure 31-1B

- Travel lanes are typically 12' to 15' in width
- CC&G is normally B.6-24. Sidewalk locations may vary
- Right-of-way limits vary from 60' to 100'
- This section is applicable for urban highways with AADT \leq 15,000

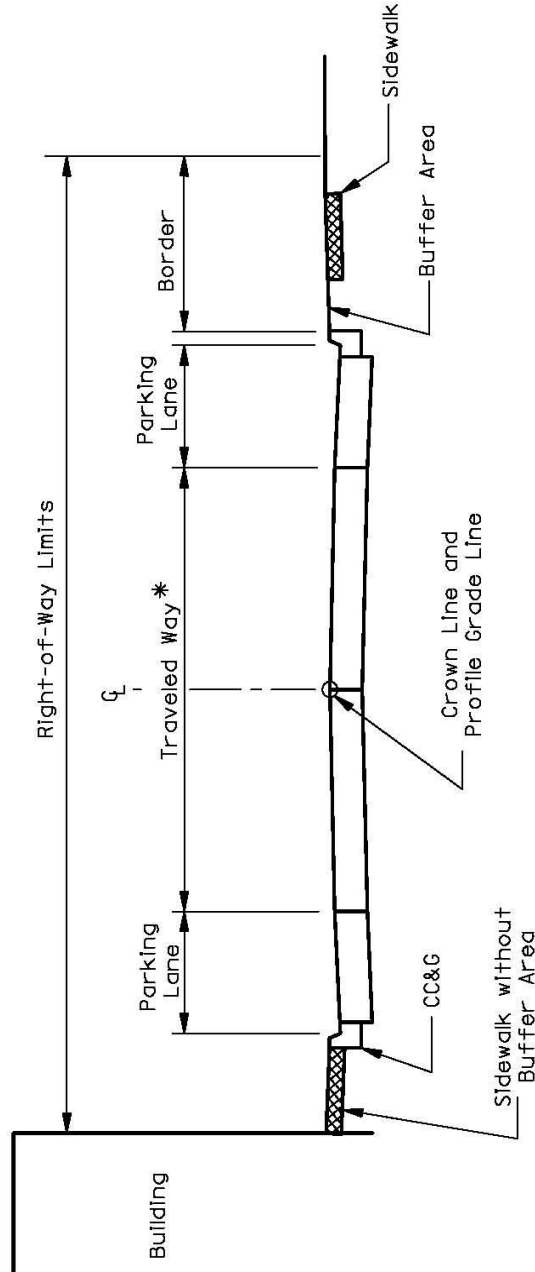

* The traveled way may have two-way or one-way traffic.

TYPICAL CROSS SECTION FOR URBAN STREETS
(Two-Lanes with Parking Both Sides)

Figure 31-1C

- Travel lanes are typically 12' to 14' in width
- Parking lanes are 8' and variable
- CC&G is normally B.6-24. Sidewalk locations may vary
- Right-of-way limits vary from 60' to 100'
- This section is applicable for urban highways with AADT \leq 15,000

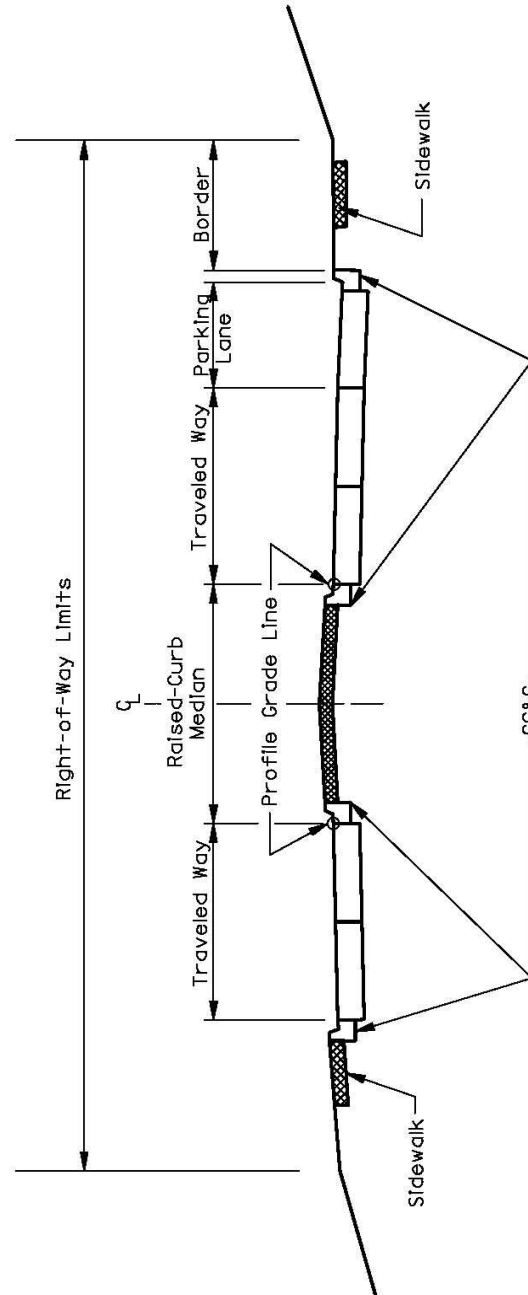

**TYPICAL CROSS SECTION FOR URBAN STREETS
(Raised-Curb Median)**

Figure 31-1E

- Travel lanes are typically 12' to 14' in width
- Median width varies from 18' to 30'
- CC&G is typically B-6.24. Sidewalk locations vary
- Right-of-way limits vary from 100' to 150'
- This section is applicable for urban or suburban highways with AADT \leq 30,000



KENDALL COUNTY HIGHWAY DEPARTMENT
5-YEAR SURFACE TRANSPORTATION PROGRAM
2025 - 2029

Revised 9/17/24

ROAD	DESCRIPTION	LIMITS	TOTAL ESTIMATE	FUNDING	YEAR	NOTES
Fox River Drive	Construction	Johnson Street Reconstruction	\$2,250,000	Trans. Sales Tax	2025	Fall 2024 Letting
Caton Farm Road	Bridge Replacement	Caton Farm Road over Aux Sable Creek	\$2,500,000	TST & Co. Bridge	2025	Fall 2024 Letting
Township Bridge	Bridge Replacement	Wheeler Rd over Middle Aux Sable Creek	\$750,000	State / Co. / Twp.	2025	80 / 10 / 10 Split
Orchard Road	Construction	Gates Creek Watershed Improvement	\$500,000	Trans. Sales Tax	2025	Spring Letting
County Highways	HMA Resurfacing	Grove Rd / Caton Farm Rd / Others	\$3,000,000	Motor Fuel Tax	2025	Spring Letting
County Highways	Safety Improvements	Various Locations	\$300,000	Motor Fuel Tax	2025	Spring Letting
Various	Signal Pre-emption	Various Locations	\$330,000	Trans. Sales Tax	2025	Spring Letting
Various	KC-TAP	Transportation Alternatives Program	\$150,000	Trans. Sales Tax	2025	
Fox River Drive	Construction Engineering	Johnson Street Reconstruction	\$230,000	Trans. Sales Tax	2025	PE 3 - EEI
Ridge Road	PE & Land Acquisition	4-Lane Section - Holt Road to Black Road	\$2,000,000	Trans. Sales Tax	2025	PE 2 & Land Acq.
Orchard Road	Engineering	Gates Creek Watershed Improvement	\$60,000	Trans. Sales Tax	2025	PE 3 - HR Green
Ridge Road	Phase 1 Engineering	4-Lane Section - CFR to Plainfield Rd	\$500,000	Trans. Sales Tax	2025	PE 1
Galena Road	Preliminary Engineering	Left Turn Bypass Lane at Rock Creek Rd	\$75,000	Trans. Sales Tax	2025	PE 1 & PE 2
Galena Road	Preliminary Engineering	Roundabout at Little Rock Rd Intersection	\$150,000	Trans. Sales Tax	2025	PE 1
Ridge Road	Construction	4-Lane Section - Holt Road to Black Road	\$12,500,000	Fed / State / Local	2026	TST Bond Issue Likely
Galena Road	Construction	Left Turn Bypass Lane at Rock Creek Rd	\$300,000	Trans. Sales Tax	2026	Spring Letting
Grove Road	Construction	Traffic Signal at Ill. Rte. 126	\$200,000	MFT	2026	IDOT Lead Agency
County Highways	HMA Resurfacing	Various Locations TBD	\$2,500,000	Motor Fuel Tax	2026	Spring Letting
County Highways	Safety Improvements	Various Locations	\$300,000	Motor Fuel Tax	2026	
Various	KC-TAP	Transportation Alternatives Program	\$150,000	Trans. Sales Tax	2026	
Ridge Road	Phase 1 Engineering	4-Lane Section - CFR to Plainfield Rd	\$750,000	Trans. Sales Tax	2026	PE 1
Galena Road	PE & Land Acquisition	Roundabout at Little Rock Rd Intersection	\$150,000	Trans. Sales Tax	2026	PE 2 & Land Acq.
Grove Road	Preliminary Engineering	Roundabout at Caton Farm Rd Intersection	\$100,000	Trans. Sales Tax	2026	PE 1
Orchard Road	Preliminary Engineering	Widen Orchard Bridge over Fox to 4 lanes	\$500,000	TST / Co. Bridge	2026	PE 2
Township Bridge	Preliminary Engineering	Reservation Road	\$100,000	Co. / Twp.	2026	50 / 50 split

Exhibit 10



KENDALL COUNTY HIGHWAY DEPARTMENT
5-YEAR SURFACE TRANSPORTATION PROGRAM
2025 - 2029

Revised 9/17/24

ROAD	DESCRIPTION	LIMITS	TOTAL ESTIMATE	FUNDING	YEAR	NOTES
Ridge Road	Construction	4-Lane Section - Holt Road to Black Road	\$12,500,000	Fed / State / Local	2027	\$25 million total
Galena Road	Construction	Roundabout at Little Rock Rd Intersection	\$750,000	Trans. Sales Tax	2027	
Township Bridge	Bridge Replacement	Reservation Road	\$1,000,000	State / Co. / Twp.	2027	80 / 10 / 10 Split
County Highways	HMA Resurfacing	Various Locations TBD	\$3,000,000	Motor Fuel Tax	2027	Spring Letting
County Highways	Safety Improvements	Various Locations	\$300,000	Motor Fuel Tax	2027	
Various	KC-TAP	Transportation Alternatives Program	\$150,000	Trans. Sales Tax	2027	
Ridge Road	PE & Land Acquisition	4-Lane Section - CFR to Plainfield Rd	\$750,000	Trans. Sales Tax	2027	PE 2 & Land Acq.
Grove Road	Preliminary Engineering	Roundabout at Caton Farm Rd Intersection	\$500,000	Trans. Sales Tax	2027	PE 2 & Land Acq.
Grove Road	Construction	Intersection Improvement at Route 52	\$100,000	Trans. Sales Tax	2027	IDOT Lead Agency
Orchard Road	Preliminary Engineering	Widen Orchard Bridge over Fox to 4 lanes	\$500,000	TST / Co. Bridge	2027	PE 2
Walker Road	Preliminary Engineering	Realignment east of Fox River Drive	\$350,000	Trans. Sales Tax	2027	PE 1
Plainfield Road	Preliminary Engineering	Intersection Improvements-Schlapp/Collins	\$200,000	Trans. Sales Tax	2027	
Grove Road	Preliminary Engineering	Intersection Improvement at Reservation Rd	\$100,000	Trans. Sales Tax	2027	PE 1
Little Rock Road	PE & Land Acquisition	Roundabout at Creek Rd Intersection	\$100,000	Trans. Sales Tax	2027	PE 2 & Land Acq.
Galena Road	Preliminary Engineering	3-Lane Section Rte 47 to Orchard Rd	\$500,000	Trans. Sales Tax	2027	PE 1
Orchard Road	Construction	Widen Orchard Bridge over Fox to 4 lanes	\$5,000,000	Fed / State / Local	2028	
Grove Road	Construction	Roundabout at Caton Farm Rd Intersection	\$750,000	Trans. Sales Tax	2028	
Little Rock Road	Construction	Roundabout at Creek Rd Intersection	\$750,000	Trans. Sales Tax	2028	
County Highways	HMA Resurfacing	Various Locations TBD	\$3,000,000	Motor Fuel Tax	2028	Spring Letting
County Highways	Safety Improvements	Various Locations	\$300,000	Motor Fuel Tax	2028	
Various	KC-TAP	Transportation Alternatives Program	\$150,000	Trans. Sales Tax	2028	
Ridge Road	PE & Land Acquisition	4-Lane Section - CFR to Plainfield Rd	\$1,000,000	Trans. Sales Tax	2028	PE 2 & Land Acq.
Walker Road	PE & Land Acquisition	Realignment east of Fox River Drive	\$600,000	Trans. Sales Tax	2028	PE 2 & Land Acq.
Plainfield Road	PE & Land Acquisition	Intersection Improvements-Schlapp/Collins	\$300,000	Trans. Sales Tax	2028	PE 2 & Land Acq.
Grove Road	PE & Land Acquisition	Intersection Improvement at Reservation Rd	\$150,000	Trans. Sales Tax	2028	PE 2 & Land Acq.

Exhibit 10



KENDALL COUNTY HIGHWAY DEPARTMENT
5-YEAR SURFACE TRANSPORTATION PROGRAM
2025 - 2029

Revised 9/17/24

Exhibit 10

ROAD	DESCRIPTION	LIMITS	TOTAL ESTIMATE	FUNDING	YEAR	NOTES
Galena Road	PE & Land Acquisition	3-Lane Section Rte 47 to Orchard Rd	\$500,000	Trans. Sales Tax	2028	PE 2 & Land Acq.
Township Bridge	Preliminary Engineering	TBD	\$100,000	Co. / Twp.	2028	50 / 50 split
Ridge Road	Construction	4-Lane Section - CFR to Plainfield Rd	\$25,000,000	Fed / State / Local	2029	\$ Sources Unknown
Walker Road	Construction	Realignment east of Fox River Drive	\$3,500,000	Trans. Sales Tax	2029	
Plainfield Road	Construction	Intersection Improvements-Schlapp/Collins	\$2,000,000	Trans. Sales Tax	2029	
Grove Road	Construction	Intersection Improvement at Reservation Rd	\$1,000,000	Trans. Sales Tax	2029	
Township Bridge	Bridge Replacement	TBD	\$750,000	State / Co. / Twp.	2029	80 / 10 /10 Split
County Highways	HMA Resurfacing	Various Locations TBD	\$3,000,000	Motor Fuel Tax	2029	Spring Letting
County Highways	Safety Improvements	Various Locations	\$300,000	Motor Fuel Tax	2029	
Various	KC-TAP	Transportation Alternatives Program	\$150,000	Trans. Sales Tax	2029	
Galena Road	PE & Land Acquisition	3-Lane Section Rte 47 to Orchard Rd	\$500,000	Trans. Sales Tax	2029	PE 2 & Land Acq.

5-Year Total: \$99,945,000

** Includes \$20 Million unsecured funding for Ridge Road - Caton Farm Rd. to Plainfield Rd.*

Estimated Grants & Funds by Others: \$14,275,000

Total Estimated County Funds: \$85,670,000

** May be reduced by \$20 million if other grant funds can be found.*