

105 111514 KONICA MINOLTA BUSINESS SOLUTI 9005961729 08/29/19 27020006200 OFFICE SUPPLIES & POSTAGE 208.38 ** gbaughe

106 021874 BRISTOL KENDALL FIRE DIST. KCFPD 08/29/19 27020006204 CONFERENCES 360.00 bantrim

107 011359 AMEREN IP 8/14/19:MILLERO MILLBROOK SOUTH 08/29/19 27020006351 ELECTRIC 69.90 bantrim

108 031510 COMMONWEALTH EDISON 8/14/19:BW BAKER WOODS 08/29/19 27020006351 ELECTRIC 21.27 bantrim

Total FOREST PRESERVE EXPENDITURE 659.55*

109 031510 COMMONWEALTH EDISON 8/14/19:EL 08/29/19 27021007076 UTILITIES - ELLIS HOUSE 455.02 bantrim

Total ELLIS HOUSE 455.02*

110 130506 MENARDS 58106 08/29/19 27021027080 GROUNDS & MAINT - ELLIS G 66.21 bantrim

Total ELLIS GROUNDS 66.21*

Dist Amount

66.21*

ELLIS CAMPS

111 101300 JOHN RYAN HORSESHOEING AUG 2019 EL-VET CARE 08/29/19 27021107084 VET & FARRIER - ELLIS CAM 126.67 ** bantrim
126.67*

126.67*

ELLIS RIDING LESSONS

112 101300 JOHN RYAN HORSESHOEING AUG 2019 EL-VET CARE 08/29/19 27021117084 VET & FARRIER - ELLIS RID 126.67 ** bantrim
126.67*

126.67*

ELLIS BIRTHDAY PARTIES

113 101300 JOHN RYAN HORSESHOEING AUG 2019 EL-VET CARE 08/29/19 27021127084 VET & FERRIER - ELLIS B-D 126.66 ** bantrim
126.66*

126.66*

HOOVER

114 140937 NICOR 8/12/19:MAINT HOVER MAINT BLDG 08/29/19 27022006860 HOOVER - GAS 36.87 bantrim
115 140937 NICOR 8/12/19:HOUSE HOVER HOUSE 08/29/19 27022006860 HOOVER - GAS 24.05 bantrim
116 140937 NICOR 8/12/19:SHOP HOVER SHOP 08/29/19 27022006860 HOOVER - GAS 45.87 bantrim
117 140937 NICOR 8/12/19:ML MEADOWHAWK 08/29/19 27022006860 HOOVER - GAS 43.45 bantrim
118 140937 NICOR 8/12/19:ROOKERY HOVER ROOKERY 08/29/19 27022006860 HOOVER - GAS 42.35 bantrim
119 140937 NICOR 8/12/19:BLAZING BLAZING STAR 08/29/19 27022006860 HOOVER - GAS 38.77 bantrim
120 140937 NICOR 8/12/19:KING KINGFISHER 08/29/19 27022006860 HOOVER - GAS 39.21 bantrim
121 140937 NICOR 8/13/19:MOON MOONSEED 08/29/19 27022006860 HOOVER - GAS 38.33 bantrim
308.90*

122 130506 MENARDS 57625 HOVER SHOP SUPPLIES 08/29/19 27022006863 HOOVER - SHOP SUPPLIES 163.92 bantrim
123 211430 UNIQUE PRODUCTS & SERVICE 371466 HOVER-CLEAN SUPPLIE 08/29/19 27022006863 HOOVER - SHOP SUPPLIES 841.30 ** bantrim
1,005.22*

124 011850 ARTLIP AND SONS INC 0195923 HOVER REPAIRS 08/29/19 27022006864 HOOVER - BUILDING MAINTEN 24.90 bantrim
125 110530 KENDALL PLUMBING & HEATING 19029290 ML-BATHHOUSE PLUMBIN 08/29/19 27022006864 HOOVER - BUILDING MAINTEN 700.00 bantrim
126 130506 MENARDS 57625 HOVER BLDG SUPPLIES 08/29/19 27022006864 HOOVER - BUILDING MAINTEN 30.07 bantrim
754.97*

127 130506 MENARDS 57625 HOVER GROUND SUPPLI 08/29/19 27022006865 HOOVER - GROUNDS MAINTENA 19.06 bantrim
19.06*

128 269210 SANJAY PATEL 19-00064 ML SEC DEP RIN 08/29/19 27022007088 HOOVER SECURITY DEPOSIT R 625.00 bantrim
129 269217 JESSICA DAVIDSON 19-00114 ML SEC DEP RIN 08/29/19 27022007088 HOOVER SECURITY DEPOSIT R 400.00 bantrim
130 269220 DIANA VILLANEUVA 19-00141 ML SEC DEP RIN 08/29/19 27022007088 HOOVER SECURITY DEPOSIT R 142.50 bantrim
131 269221 BOB ALLGOOD 19-00203 BUNKHOUSE SEC DEP RT 08/29/19 27022007088 HOOVER SECURITY DEPOSIT R 100.00 bantrim
1,267.50*

1,267.50*

Vendor #	Name	Invoice #	Description	Date	Budget #	Account Description	Dist Amount
ENV ED CAMPS							
132 269209	REBECCA COLLIER	CAMP	CAMP REFUND	08/29/19	27023027088	SECURITY DEPOSIT REFUNDS	130.00 130.00*
Total HOOPER							3,355.65*
NATURAL AREA VOLUNTEER							
133 130506	MENARDS	58439	HOOPER -WORK DAY	08/29/19	27024006835	NATURAL AREA VOLUNTEER SU	36.92 36.92*
Total ENV ED CAMPS							130.00*
GROUND & NATURAL RESOURCES							
134 012290	AUTOMOTIVE SPECIALTIES INC	23714	'08 FORD-OIL, FILTER	08/29/19	27025006216	EQUIP - GROUNDS & NATURAL	90.45
135 040538	DEKANE EQUIPMENT CORP	1A66261	HOOPER-MOWER TIRE RE	08/29/19	27025006216	EQUIP - GROUNDS & NATURAL	219.46 309.91*
136 269218	ANTONETTE MECIEJ	08-15-19	UNIFOR UNIFORMS-NB STAFF	08/29/19	27025006240	UNIFORMS	141.60 141.60*
137 030540	CENTRAL LIMESTONE CO INC	18252	JAY WOODS-IMPROVEMEN	08/29/19	27025006837	PRESERVE IMPROV - GR & NA	9.79 9.79*
138 140937	NICOR	8/8/19:MILL	MILLBROOK SOUTH	08/29/19	27025006848	GAS - GROUNDS & NATURAL R	109.60
139 140937	NICOR	8/13/19:HA	HARRIS	08/29/19	27025006848	GAS - GROUNDS & NATURAL R	42.33 151.93*
140 211430	UNIQUE PRODUCTS & SERVICE	371466	HARRIS-CLEAN SUPPLIE	08/29/19	27025007089	SUPPLIES - SHOP	560.87 560.87*
Total GROUND & NATURAL RESOURCES							1,174.10*

Vendor#	Name	Invoice #	Description	Date	Budget #	Account Description	Dist Amount
FP BOND PROCEEDS 2007							
205 080151	HAMPTON, LENZINI & RENWICK INC	20191562	MILLBROOK BRIDGE	08/29/19	95020006850	PROJECT FUND EXPENSES	6,637.50
206 091207	IL DEPT OF NAT'L RESOURCES	ABC	BOAT ACCESS AREA DEV	08/29/19	95020006850	PROJECT FUND EXPENSES	300.00 ***
207 172130	QUICK SIGNS	20367	EQUEST. TRAIL SIGNS	08/29/19	95020006850	PROJECT FUND EXPENSES	300.00
208 172130	QUICK SIGNS	20207	PICKERILL SIGNAGE	08/29/19	95020006850	PROJECT FUND EXPENSES	150.00
209 190610	SEMPER FI YARD SERVICES	2019-1606	HENNEBERRY-EROSION C	08/29/19	95020006850	PROJECT FUND EXPENSES	9,050.00
							16,437.50*
Total FP BOND PROCEEDS 2007							16,437.50*
FP BOND PROCEEDS 2007							
210 161577	POSSIBILITY PLACE NURSERY	00116354	HOOVER RESTORATION	08/29/19	95024006855	NATURAL AREAS MANAGEMENT	4,628.40
							4,628.40*
Total FP BOND PROCEEDS 2007							4,628.40*

Total Claims \$27,323.35

**KENDALL COUNTY FOREST PRESERVE DISTRICT
COMMITTEE OF THE WHOLE MEETING MINUTES**

AUGUST 13, 2019

I. Call to Order

President Gilmour called the Committee of the Whole meeting to order at 5:25 pm in the Kendall County Board Room.

II. Roll Call

Commissioners Flowers, Gengler, Gilmour, Hendrix, Prochaska, and Vickers all were present. Commissioner Gryder entered the meeting at 5:27 pm.

III. Approval of Agenda

Commissioner Flowers made a motion to approve the agenda as presented. Seconded by Commissioner Vickers. All, aye. Opposed, none.

IV. Public Comments

Rebecca Antrim, Administrative Assistant expressed appreciation and encouraged approval of the items on the agenda pertaining to Director Guritz's increase and lease agreement.

V. Executive Session

Commissioner Hendrix made a motion to enter executive session at 5:27 pm under 2(c)1 to discuss the appointment, employment, compensation, discipline, performance, or dismissal of specific employees of the public body or legal counsel for the public body, including hearing testimony on a complaint lodged against an employee of the public body or against legal counsel for the public body to determine its validity. Seconded by Commissioner Flowers. Aye, all. Opposed, none.

Roll call: Commissioner Flowers, Gengler, Gilmour, Hendrix, Prochaska, and Vickers were all present.

Commissioner Gryder entered the meeting at 5:27 pm.

Commissioner Flowers made a motion to adjourn executive session. Seconded by Commissioner Vickers. Aye, all. Opposed, none.

Regular meeting reconvened at 5:38 pm.

VI. Executive Director's Report

Director Guritz provided an executive director's report providing updates on the Hoover crossing agreement, and efforts to locate the Subat Forest Preserve drain tile system. The Hoover crossing

agreement has been finalized. Kendall Excavating completed contracted work to backfill the exposed sewer line and address future bluff erosion.

VII. MOTION: Forward Claims to Commission for an Amount Not-to-Exceed \$30,089.14

Director Guritz presented claims for an amount not-to-exceed \$30,089.14.

Commissioner Flowers made a motion to forward claims to Commission for an amount not-to-exceed \$30,089.14. Seconded by Commissioner Hendrix. Aye, all. Opposed, none.

VIII. Review of Financial Statements and Cost Center Reports for the Period Ending July 31, 2019

Director Guritz presented a review of the financial statements and cost center reports for the period ending July 31, 2019.

OLD BUSINESS

No agenda items posted for consideration.

NEW BUSINESS

IX. Illinois Department of Natural Resources – State Pheasant Fund Advisory Committee Grant for Support of Cropland Conversion Efforts at Fox River Bluffs Forest Preserve

Director Guritz presented overviews of the Illinois Department of Natural Resources – State Pheasant Fund Advisory Committee and IDNR-Habitat Fund grant programs that could extend additional support for cropland conversion efforts at Fox River Bluffs Forest Preserve. A match of funds scheduled for appropriation and expenditure in FY20 will serve as a 50% match within the application.

X. Review of a Final Draft of the Tri-Party Crossing Agreement (Yorkville – Kendall County Forest Preserve District – OmniTRAX/Illinois Railway) for Hoover Road at Hoover Forest Preserve

Director Guritz presented a review of a final draft of the tri-Party crossing agreement between Illinois Railway/OmniTRAX, the United City of Yorkville and Kendall County Forest Preserve District.

Commissioner Hendrix made a motion to forward the review of a final draft of the tri-party crossing agreement for Hoover Road at Hoover Forest Preserve to Commission for consideration. Seconded by Commissioner Flowers. Aye, all. Opposed, none.

XI. Other Items of Business

- **Millington Village Board Presentation – Freeman Forest Preserve Boat Launch Area Improvements**

Director Guritz presented an overview of the Millington Village Board discussions on the proposed boat launch area at Freeman Forest Preserve. The Village Board unanimously approved a motion to forward a letter of support for the District's application.

The Committee of the Whole discussed the Boat Access Area Development (BAAD) grant application and gave direction to submit the application with no matching funds.

- **Hoover Forest Preserve – ICECF Community Restoration Challenge Grant – Pizzo & Associates Woodland Clearing Proposal**
- **Drain Tile and Culvert Clearing Project Updates (Subat, Jay Woods, and Little Rock Creek)**

Director Guritz provided an overview and updates on progress with the ICECF Community Restoration Challenge Grant and pending drain tile clearing projects.

XII. Summary of Action Items

Director Guritz provided a summary of action items. Items moving forward for Commission consideration included the submission of a grant application to the Pheasant/Habitat Funds, a proposal from Pizzo for woodland clearing at Hoover, once confirmed, and proposals for drain tile and culvert clearing project efforts at Subat, Jay Woods, and Little Rock Creek.

XIII. Public Comments

No public comments were offered by citizens in attendance.

XIV. Adjournment

Commissioner Hendrix made a motion to adjourn the meeting at 6:16 pm. Seconded by Commissioner Flowers. Aye, all. Opposed, none.

Respectfully submitted,

David Guritz
Executive Director, Kendall County Forest Preserve District

**KENDALL COUNTY FOREST PRESERVE DISTRICT
SPECIAL CALL COMMISSION MEETING MINUTES**

AUGUST 13, 2019

I. Call to Order

President Gilmour called the meeting to order at 6:28 pm in the Kendall County Board Room.

II. Pledge of Allegiance

All present recited the Pledge of Allegiance.

III. Invocation

Commissioner Prochaska offered an Invocation for the meeting.

IV. Roll Call

	Cesich	X	Hendrix
X	Flowers		Kellogg
	Giles	X	Prochaska
X	Gilmour	X	Gengler
X	Gryder	X	Vickers

Commissioners Flowers, Gengler, Gryder, Hendrix, Prochaska, Vickers and Gilmour were present.

V. Approval of Agenda

Commissioner Hendrix made a motion to approve the agenda as presented. Seconded by Commissioner Flowers. Aye, all. Opposed, none.

VI. Public Comment

No public comments were offered from citizens in attendance.

OLD BUSINESS

VII. MOTION: Approval of a Temporary Stipend for David Guritz, Executive Director of the KCFPD, in the Amount of \$392.30 Per Pay Period, from August 23, 2019 to Nov. 30, 2020, Effective August 23, 2019

Commissioner Gryder made a motion to forward the approval of a temporary stipend for David Guritz, Executive Director of the KCFPD, in the amount of \$392.30 per pay period, from August 23,

2019 to Nov. 30, 2020, effective August 23, 2019, to Commission on August 27, 2019.

Commissioner Gryder cited concerns over Commissioners not present at the meeting.

Motion failed due to lack of a second.

President Gilmour addressed the need to approve the stipend, citing the need to move on to address the District's more pressing issues.

Commissioner Hendrix made a motion to approve a temporary stipend for David Guritz, Executive Director of the KCFPD, in the amount of \$392.30 per pay period, from August 23, 2019 to Nov. 30, 2020, effective August 23, 2019. Seconded by Commissioner Flowers.

Motion: Commissioner Hendrix					
Second: Commissioner Flowers					
Roll call: Temporary Stipend					
Aye	Opposed	Commissioner	Aye	Opposed	Commissioner
		Cesich	X		Hendrix
X		Flowers			Kellogg
		Giles	X		Prochaska
X		Gilmour	X		Gengler
	X	Gryder	X		Vickers
Motion carried by a vote of 6:1.					

VIII. MOTION: Approval of a Two-Year Lease Agreement between the Kendall County Forest Preserve District and David Guritz, Executive Director for Use of the Pickerill Estate House "Maid's Room," Adjoining Washroom, Laundry Room, Kitchen Area, Garage Stall, and Basement Storage Area as a Private Residence at Pickerill-Pigott Forest Preserve for an Initial Monthly Rent Payment of \$913.00, Subject to Change in Accordance with the Kendall County Housing Authority Payment Standards Thereafter, Including Payment of a \$1,000.00 Rental Security Deposit

Director Guritz presented a two-year lease agreement between the Kendall County Forest Preserve District and David Guritz, Executive Director for use of the Pickerill Estate House "Maid's room," adjoining washroom, laundry room, kitchen area, garage stall, and basement storage area as a private residence at Pickerill-Pigott Forest Preserve for an initial monthly rent payment of \$913.00, subject to change in accordance with the Kendall County Housing Authority payment standards thereafter, including payment of a \$1,000.00 rental security deposit.

Commissioner Hendrix made a motion to approve a two-year lease agreement between the Kendall County Forest Preserve District and David Guritz, Executive Director for use of the Pickerill Estate House "maid's room," adjoining washroom, laundry room, kitchen area, garage stall, and basement storage area as a private residence at Pickerill-Pigott Forest Preserve for an initial monthly rent payment of \$913.00, subject to change in accordance with the Kendall County

Housing Authority payment standards thereafter, including payment of a \$1,000.00 rental security deposit. Seconded by Commissioner Flowers.

<p>Motion: Commissioner Hendrix Second: Commissioner Flowers</p>					
<p>Roll call: Lease Agreement</p>					
Aye	Opposed	Commissioner	Aye	Opposed	Commissioner
		Cesich	X		Hendrix
X		Flowers			Kellogg
		Giles	X		Prochaska
X		Gilmour	X		Gengler
	X	Gryder	X		Vickers
<p>Motion carried by a vote of 6:1.</p>					

NEW BUSINESS

IX. MOTION: Authorizing Submission of a \$30,000.00 Grant Request to the Illinois Department of Natural Resources – State Pheasant Fund Advisory Committee for Support of the Cropland Conversion, Prairie and Reforestation Project at Fox River Bluffs Forest Preserve, Including a Commitment of \$30,000.00 of District Matching Funds

Director Guritz presented an overview and requested authorization to submit a \$30,000.00 grant request to the Illinois Department of Natural Resources – State Pheasant Fund Advisory Committee for support of the cropland conversion, prairie restoration, and reforestation project at Fox River Bluffs Forest Preserve, including a commitment of \$30,000.00 in District matching funds.

Commissioner Hendrix made a motion to approve the authorization of the submission of a \$30,000.00 grant request to the Illinois Department of Natural Resources – State Pheasant Fund Advisory Committee for support of the cropland conversion, prairie restoration, and reforestation project at Fox River Bluffs Forest Preserve, including a commitment of \$30,000.00 of District matching funds. Seconded by Commissioner Flowers.

Director Guritz remarked that there are two programs under which the District plans to apply for consideration, and requested that the agenda be amended to reflect the District’s application to the two programs. Either proposal could receive funding, but if awarded, the application would be withdrawn from consideration from the other program.

Commissioner Hendrix made a motion to amend the motion to include the Illinois Department of Natural Resources Habitat Fund and the Illinois Department of Natural Resources Pheasant Fund programs. Seconded by Commissioner Flowers.

Motion: Commissioner Hendrix
Second: Commissioner Flowers

Roll call: Motion Amendment

Aye	Opposed	Commissioner	Aye	Opposed	Commissioner
		Cesich	X		Hendrix
X		Flowers			Kellogg
		Giles	X		Prochaska
X		Gilmour	X		Gengler
X		Gryder	X		Vickers

Motion unanimously approved.

Motion: Commissioner Hendrix
Second: Commissioner Flowers

Roll call: Grant Application

Aye	Opposed	Commissioner	Aye	Opposed	Commissioner
		Cesich	X		Hendrix
X		Flowers			Kellogg
		Giles	X		Prochaska
X		Gilmour	X		Gengler
X		Gryder	X		Vickers

Motion unanimously approved.

X. MOTION: Approval of Fees and Charges for Fall 2019 Public Program Offerings

Director Guritz presented a request to approve the proposed fees and charges for fall 2019 public program offerings.

Commissioner Hendrix made a motion to approve the fees and charges for fall 2019 public program offerings. Seconded by Commissioner Flowers.

Motion: Commissioner Hendrix
Second: Commissioner Flowers

Roll call: Fees and Charges

Aye	Opposed	Commissioner	Aye	Opposed	Commissioner
		Cesich	X		Hendrix
X		Flowers			Kellogg
		Giles	X		Prochaska
X		Gilmour	X		Gengler
X		Gryder	X		Vickers

Motion unanimously approved.

XI. Executive Session

There was no need for executive session.

XII. Other Items of Business

There were no other items of business.

XIII. Public Comments

No public comments were offered by citizens in attendance.

XIV. Adjournment

Commissioner Gryder made a motion to adjourn. Seconded by Commissioner Flowers. Aye, all. Opposed, none. Meeting adjourned at 7:44 pm.

Respectfully submitted,

David Guritz

Director, Kendall County Forest Preserve District

To: Kendall County Forest Preserve District Board of Commissioners
From: David Guritz, Director
**RE: Committee Reassignments and Appointment of Scott Gengler to Finance
Committee Chair**
Date: September 3, 2019

In accordance with the Kendall County Forest Preserve District Rules of Order approved by Resolution #17-06-003 on June 17, 2017:

Appointment of Chairman and Vice-Chairman

The President of the District, with the advice and consent of a majority of Commissioners present, shall appoint a Chair for each Standing and Special Committee. The Chair of each Committee shall appoint a Vice-Chairman from the membership of the Committee with the advice and consent of the Committee members present. In the absence of the Chairman, the Vice-Chairman shall conduct the Committee meeting.

Also, per the Rules of Order, all standing committees shall have no more than 5 members with the exception of the Committee of the Whole.

Commissioner Kellogg has indicated interest in stepping down from his current role as Finance Committee Chair, and Commissioner Gengler has expressed interest in assuming this role.

Recommendation:

Consider a motion to approve the appointment of Commissioner Kellogg to the District's Operations Committee, and Scott Gengler as Chairman of the District's Finance Committee.

To: Kendall County Forest Preserve District Board of Commissioners

From: David Guritz, Director

RE: Innovative Underground Proposals

Date: September 3, 2019

Kendall County Forest Preserve District has identified three drainage projects to address prior to the end of FY19.

At Jay Woods Forest Preserve, Harold Smith, the adjacent land owner and farmer approached the District requesting support of clearing out a known existing drain tile located in the western quarter of the preserve. Mr. Smith has offered to excavate and expose the tile for clearing later this fall.

At Little Rock Creek Forest Preserve, trail washout is a concern for the recently installed bluff access trail/road. Existing infrastructure has been located and once cleared should address this problem.

At Subat Forest Preserve, a third proposal will be brought forward for clearing of a tile outlet into Rob Roy Creek once the District is able to confirm that the District's tile drains into the outlet structure identified during field investigations. The proposal for clearing the tile outlet is \$2,400.00

Recommendations:

Consider two separate motions to approve each of the two proposals received from Innovative Underground, Inc. to complete drain tile clearing and possible repair work at Jay Woods Forest Preserve for an amount not-to-exceed \$2,400, and a proposal received for hydro-excavation, discharge location and televising of pipe conditions at Little Rock Creek Forest Preserve for an amount not-to-exceed \$3,800.



INNOVATIVE UNDERGROUND

2175C GRISWOLD SPRINGS RD., SANDWICH IL 60548
331-300-5225

Kendall County Forest Preserve District
Attn: Dave Gurtz
Yorkville IL

PROPOSAL
8/28/2019

PROJECT: JAY WOODS FOREST PRESERVE, PLANO, IL, STORM SEWER IMPROVEMENTS

NO.	ITEM	PROPOSED AMOUNTS			
		QTY	U/M	PRICE	AMOUNT

	JET FIELD TILE TO DRAIN EXCESS "PONDING" AREAS, TELEWISE IF POSSIBLE	8	HR	\$ 300.00	\$ 2,400.00
--	---	---	----	-----------	-------------

PROPOSAL TOTAL

\$ 2,400.00

SCOPE OF WORK:

- CLEAN & TELEWISE FIELD TILE
- INSTALL REPAIRS USING NO DIG METHODS
- PROVIDE POST CLEANING VIDEO (IF POSSIBLE)

PROVIDED BY OTHERS:

- ACCESS HOLES EXCAVATED BY FARMER OR OTHER

RANDY HARKER, PRESIDENT

DATE

PROPOSAL VALID FOR 30 DAYS

TERMS: DUE UPON COMPLETION

WARRANTY: 5 YEARS FROM DATE OF INSTALLATION FOR LINERS

WARRANTY: 1 YEAR FROM DATE OF CLEANING (IF CLEANING IS ALL THAT IS DONE)

SIGNATURE OF ACCEPTANCE

DATE



INNOVATIVE UNDERGROUND

2175C GRISWOLD SPRINGS RD., SANDWICH IL 60548
331-300-5225

Kendall County Forest Preserve District
Attn: Dave Guritz
Yorkville IL

PROPOSAL
8/28/2019

PROJECT: LITTLE ROCK FOREST PRESERVE, PLANO, IL, STORM SEWER IMPROVEMENTS

NO.	ITEM	PROPOSED AMOUNTS			
		QTY	U/M	PRICE	AMOUNT
1	JET/CLEAN & LOCATE 3 OR 4 CULVERTS	6	HR	\$ 300.00	\$ 1,800.00
2	LOCATE AND PIPE DISCHARGING INTO DUCK POND	2	HR	\$ 300.00	\$ 600.00
3	VACTOR/HYDRO EXCAVATE LARGE CULVERT BASIN TO REMOVE DEBRIS BUILT UP IN PIPE	4	HR	\$ 350.00	\$ 1,400.00

PROPOSAL TOTAL

\$ 3,800.00

SCOPE OF WORK:

- CLEAN & TELEWISE CULVERTS
- PROVIDE POST CLEANING VIDEO (IF POSSIBLE)

RANDY HARKER, PRESIDENT

DATE

PROPOSAL VALID FOR 30 DAYS

TERMS: DUE UPON COMPLETION

WARRANTY: 5 YEARS FROM DATE OF INSTALLATION FOR LINERS

WARRANTY: 1 YEAR FROM DATE OF CLEANING (IF CLEANING IS ALL THAT IS DONE)

SIGNATURE OF ACCEPTANCE

DATE

To: Kendall County Forest Preserve District Board of Commissioners

From: David Guritz, Director

RE: Meadowhawk Lodge Staining Project

Date: September 3, 2019

The District secured three quotes for staining Meadowhawk Lodge, including surface preparation, protecting of finishes, and application of two coats of stain to the exterior cedar shingles and deck trellis area.

CertaPro Painters of Aurora submitted the lowest comparable quote to complete the work, including a two-year warranty for an amount not-to-exceed \$20,553.00

Recommendations:

Consider a motion to approve the CertaPro of Aurora, Illinois proposal for staining of Meadowhawk Lodge for a cost not-to-exceed \$20,553.00.

Exterior Staining Projection for Kendall County Park District, Meadow Hawk Lodge

SCOPE OF PROJECT:

Exterior Items Include:

- Re-stain all cedar shingle siding and upper wood soffits, applying two coats of Sherwin-Williams Woodscapes Semi-Transparent Stain.
- Re-caulk windows to sidings as needed, using Quad OSI in best color match.
- Re-stain pergola base posts, and all cross beams and short support posts.
- EXCLUDED at customer request entrance canopy.

PREPARATION

(NOTE: All materials to be stored in a secured on-site trailer. Materials shall be delivered to job site in their original containers with labels intact.)

Painting Notices to be posted no less than 10 working days from anticipated start date of project.

- Homeowners to remove/replace all items on the balconies.
- Power wash all surfaces to be painted with Tri-sodium Phosphate (non-harmful to humans or vegetation) to remove all residue. Scrub "black molding areas".
- All areas will be thoroughly dry before applying any caulk or primer. Customer to provide access to a water source.
- Cover all light fixtures.
- Remove defective caulk on the specified joints only where the caulk is no longer adhering to the outer surfaces and caulk (where necessary) all wood-to-window or wood-to-door frames joints (if previously caulked) with Quad OSI caulk.
- CertaPro will remove/reinstall all address numbers and downspouts (unless riveted).

- CertaPro will always use drop cloths and clean up all areas at the end of each day and all refuse will be disposed of off premises.
- CertaPro will provide onsite job site supervisor during regular working hours and 24 hr. access to customers for any questions concerning project progress, scheduling or general inquires.

PRODCUT SPECIFICATIONS

Any exposed substrates, including new wood, will be primed with an all-purpose primer after proper surface preparation.

Primer: Exterior Oil-Based Wood Primer is designed for blocking tannin, water, and other stains on exterior wood, manufactured siding, hardboard, rough sawn siding, and trim as a spot primer or overall primer. • Penetrates and seals bare wood

Soffit Topcoat: SuperPaint Exterior Latex High Gloss, with improved resistance to early dirt pick up, provides outstanding performance on properly prepared aluminum and vinyl siding, wood, hardboard, masonry, cement, brick, block, stucco, and metal.

Siding Stain: WoodScapes Waterbased Exterior Polyurethane Semi-Transparent Stain provides a lasting, mildew resistant film with excellent penetration for protecting most vertical exterior wood surfaces. It can be applied at air, surface, and material temperatures as low as 35°F.

WARRANTY AND INSURANCE

CertaPro will guarantee the coats applied by our company for the period of **two (2) years** from the date of application.

All extras must be approved by written authorization prior to their commencement.

All materials will be applied in accordance with the manufacturer's specifications.

CertaPro will be fully insured with Workmen's Compensation and General Liability coverage upon request.

CertaPro will add the customer's name as an Additional Insured Certificate.

PRICING

Siding Staining and Wood Soffit Painting, with caulking: \$20,553

**Meadow Hawk Lodge
Kendall County Park District**



BUSINESS & COMMERCIAL SERVICES

Meadow Hawk Lodge



CertaPro Painters of Aurora

**614 Prairie St
Aurora, IL 60506**

**Christina M Didech
Commercial Marketing
Associate**

**866-715-0882
630-432-5916 Cell
cdidech@certapro.com**

CertaPro Painters of Aurora



BUSINESS & COMMERCIAL SERVICES

Meadow Hawk Lodge

■ SCOPE OF WORK

■ EXTERIOR ITEMS INCLUDE

- Re-stain all cedar shingle siding and upper wood soffits**
- Re-caulk windows to sidings as needed, using Quad OSI in best color match**
- Re-stain pergola base posts, and all cross beams and short support posts**
- EXCLUDED at customer request entrance canopy**

■ PREPARATION:

- (NOTE: All materials to be stored in a secured on-site trailer. Materials shall be delivered to job sit in their original containers with labels intact.)**
- Painting Notices to be posted for start date of project**
- Power wash all surfaces to be stained/painted with Tri-Sodium Phosphate (non-harmful to humans or vegetation) to remove all residue. Scrub :black molding areas". Customer to provide access to a water source**
- All areas will be thoroughly dry before applying any caulk or primer.**
- Remove defective specified joints only where the caulk is no longer adhering to the outer surfaces and caulk (where necessary) all wood-to-window or wood-to-door frame joints (if previously caulked) with Quad OSI caulk.**

Meadow Hawk Lodge

■ PREPARATION:

- CertaPro will remove/reinstall all downspouts (unless riveted) IF NECESSARY
- CertaPro will use drop cloths and clean up all areas at the end of each day and all refuse will be disposed of off premises
- CertaPro will provide onsite job site supervisor during regular working hours and access to Commercial Manager (Christina Didech) for any questions concerning project progress, scheduling or general inquiries.

■ PRODUCT SPECIFICATIONS

- Any exposed substrates, including new wood, will be primed with an all-purpose primer after proper surface preparation
- **Primer: Aqua Lock Plus Primer, by INSLX** is a 100% acrylic primer that provides excellent adhesion to a variety of interior & exterior surfaces. It has superior sealing and coverage qualities, product versatility and is an excellent base coat for both latex and oil-based finish coating. It offers excellent stain blocking properties for water stains, wood tannin fingerprints, smoke, crayons and more. This product contains an agent that inhibits the growth of mildew on the surface of the paint film.

Meadow Hawk Lodge

■ PRODUCT SPECIFICATIONS

- **Soffit Topcoat:** *Moorgard Exterior Paint, by Benjamin-Moore*, a premium quality, 100% acrylic exterior house paint in a popular low luster finish. Our latest technological improvement, using 100% acrylic resin and proprietary alkyd technology, provides a protective exterior coating that will remain looking fresh A premium quality, 100% acrylic exterior house paint in a popular low luster finish. Our latest technological improvement, using 100% acrylic resin and proprietary alkyd technology, provides a protective exterior coating that will remain looking freshly painted years after the job is finished. These high solids formula delivers excellent durability, long lasting protection, and is suitable for a variety of exterior surfaces and can be applied at a wider temperature range. Previously painted years after the job is finished. These high solids formula delivers excellent durability, long lasting protection, and is suitable for a variety of exterior surfaces and can be applied at a wider temperature range.
- **Siding Stain:** *Arbor coat, by Benjamin-Moore* is a premium quality waterborne alkyd/acrylic semi-transparent stain formulated to penetrate, protect, and beautify wood siding, decks, fences or furniture. Its semi-transparent color allows the grain pattern and texture of the wood to show through. Generally, one coat of stain is enough on properly prepared substrates.

Meadow Hawk Lodge

WARRANTY AND INSURANCE

- ✔** CertaPro will guarantee the coats applied by our company for the period of TWO years from the date of application
- ✔** All extras must be approved by written authorization prior to their commencement
- ✔** All materials will be applied in accordance with the manufacturer's specifications
- ✔** CertaPro will be full insured with Workmen's Compensation and General Liability coverage
- ✔** CertaPro will add the customer's name as an additions insured certificate

Meadow Hawk Lodge



CertaPro Painters of Aurora



BUSINESS & COMMERCIAL SERVICES

Meadow Hawk Lodge

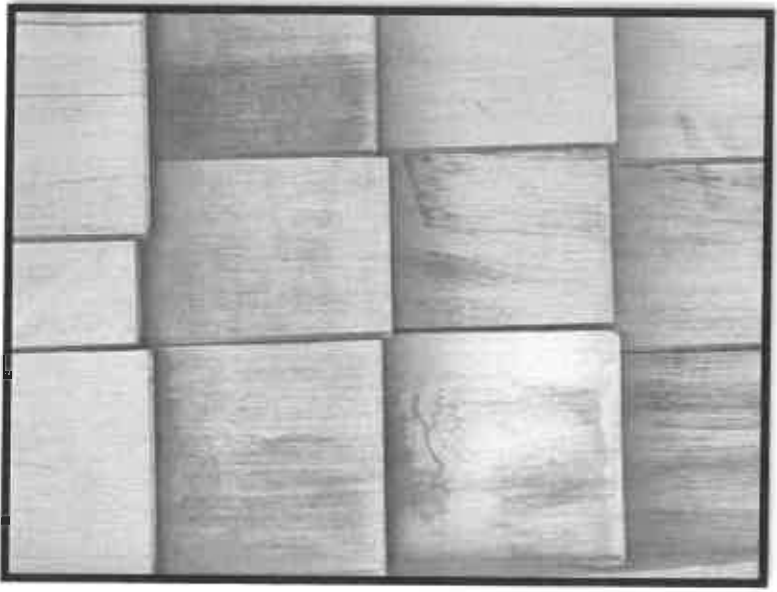

CertaPro Painters of Aurora



BUSINESS & COMMERCIAL SERVICES

Meadow Hawk Lodge

Price of Included Items (All labor, paint, materials)	Inclusions	Exclusions	Down Payment
Siding staining and wood soffit painting with caulking	yes	no	40% requested
Grand Total			\$12,362.00
Deposits Due			
Payments Received			
TOTAL			



Meadow Hawk Lodge

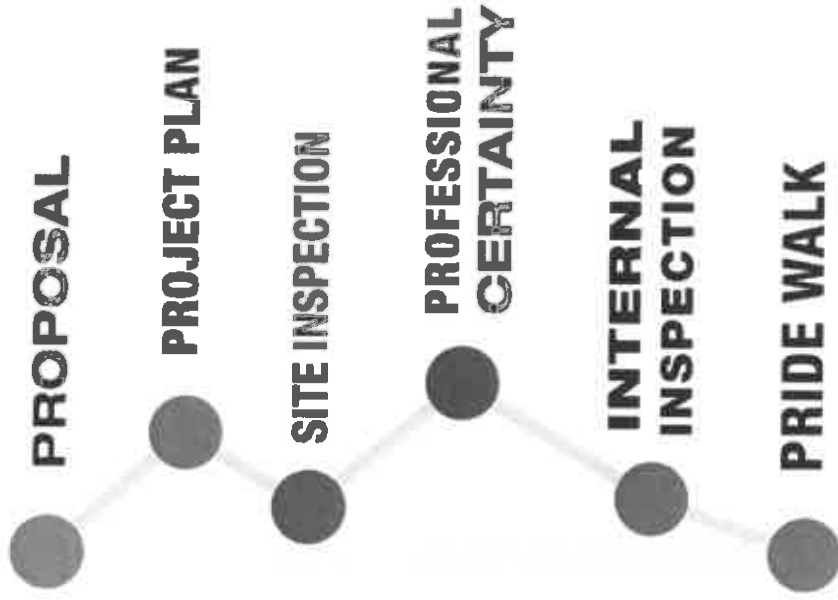

COMMERCIAL CERTAINTY SYSTEM®

Each CertaPro Painters® business is independently owned and operated.
© 2019 All Rights Reserved. Certa ProPainters, Ltd.



BUSINESS & COMMERCIAL SERVICES

**THANK YOU FOR YOUR TIME and
THE OPPORTUNITY TO EARN YOUR BUSINESS**

**Christina Didech
CertaPro Painters of Aurora**



BUSINESS & COMMERCIAL SERVICES



CERTIFICATE OF LIABILITY INSURANCE

DATE (MM/DD/YYYY)

09/03/2019

THIS CERTIFICATE IS ISSUED AS A MATTER OF INFORMATION ONLY AND CONFERS NO RIGHTS UPON THE CERTIFICATE HOLDER. THIS CERTIFICATE DOES NOT AFFIRMATIVELY OR NEGATIVELY AMEND, EXTEND OR ALTER THE COVERAGE AFFORDED BY THE POLICIES BELOW. THIS CERTIFICATE OF INSURANCE DOES NOT CONSTITUTE A CONTRACT BETWEEN THE ISSUING INSURER(S), AUTHORIZED REPRESENTATIVE OR PRODUCER, AND THE CERTIFICATE HOLDER.

IMPORTANT: If the certificate holder is an ADDITIONAL INSURED, the policy(ies) must have ADDITIONAL INSURED provisions or be endorsed. If SUBROGATION IS WAIVED, subject to the terms and conditions of the policy, certain policies may require an endorsement. A statement on this certificate does not confer rights to the certificate holder in lieu of such endorsement(s).

PRODUCER Hell & Hell Insurance Agency LLC 5215 Old Orchard Rd. Suite 300 Skokie IL 80077		CONTACT NAME: Amanda Bielko PHONE (A/C, No, Ext): (847) 888-7400 FAX (A/C, No): (847) 985-8600 E-MAIL ADDRESS: abielko@hellandhell.com	
		INSURER(S) AFFORDING COVERAGE	
		INSURER A: Pekin Insurance	NAIC # 24228
		INSURER B:	
		INSURER C:	
		INSURER D:	
		INSURER E:	
		INSURER F:	

COVERAGES **CERTIFICATE NUMBER:** CL1941821218 **REVISION NUMBER:**

THIS IS TO CERTIFY THAT THE POLICIES OF INSURANCE LISTED BELOW HAVE BEEN ISSUED TO THE INSURED NAMED ABOVE FOR THE POLICY PERIOD INDICATED. NOTWITHSTANDING ANY REQUIREMENT, TERM OR CONDITION OF ANY CONTRACT OR OTHER DOCUMENT WITH RESPECT TO WHICH THIS CERTIFICATE MAY BE ISSUED OR MAY PERTAIN, THE INSURANCE AFFORDED BY THE POLICIES DESCRIBED HEREIN IS SUBJECT TO ALL THE TERMS, EXCLUSIONS AND CONDITIONS OF SUCH POLICIES. LIMITS SHOWN MAY HAVE BEEN REDUCED BY PAID CLAIMS.

INSR LTR	TYPE OF INSURANCE	ADDL INSD	SUBR WVD	POLICY NUMBER	POLICY EFF (MM/DD/YYYY)	POLICY EXP (MM/DD/YYYY)	LIMITS								
A	<input checked="" type="checkbox"/> COMMERCIAL GENERAL LIABILITY <input type="checkbox"/> CLAIMS-MADE <input checked="" type="checkbox"/> OCCUR GEN'L AGGREGATE LIMIT APPLIES PER: <input checked="" type="checkbox"/> POLICY <input type="checkbox"/> PRO-JECT <input type="checkbox"/> LOC OTHER:			CL0240405	04/01/2019	04/01/2020	EACH OCCURRENCE \$ 2,000,000 DAMAGE TO RENTED PREMISES (Ea occurrence) \$ 100,000 MED EXP (Any one person) \$ 5,000 PERSONAL & ADV INJURY \$ 2,000,000 GENERAL AGGREGATE \$ 4,000,000 PRODUCTS - COMP/OP AGG \$ 4,000,000 \$								
A	AUTOMOBILE LIABILITY <input checked="" type="checkbox"/> ANY AUTO <input type="checkbox"/> OWNED AUTOS ONLY <input type="checkbox"/> SCHEDULED AUTOS <input type="checkbox"/> HIRED AUTOS ONLY <input type="checkbox"/> NON-OWNED AUTOS ONLY			00P729997	04/01/2019	04/01/2020	COMBINED SINGLE LIMIT (Ea accident) \$ 1,000,000 BODILY INJURY (Per person) \$ BODILY INJURY (Per accident) \$ PROPERTY DAMAGE (Per accident) \$ Medical payments \$ 5,000								
A	<input checked="" type="checkbox"/> UMBRELLA LIAB <input type="checkbox"/> OCCUR <input type="checkbox"/> EXCESS LIAB <input checked="" type="checkbox"/> CLAIMS-MADE DED <input checked="" type="checkbox"/> RETENTION \$ 10,000			00CU36614	04/01/2019	04/01/2020	EACH OCCURRENCE \$ 2,000,000 AGGREGATE \$ 2,000,000 \$								
A	WORKERS COMPENSATION AND EMPLOYERS' LIABILITY ANY PROPRIETOR/PARTNER/EXECUTIVE OFFICER/MEMBER EXCLUDED? (Mandatory in NH) If yes, describe under DESCRIPTION OF OPERATIONS below	Y/N	N/A	005384327	04/25/2019	04/01/2020	<table border="1"> <tr> <td>PER STATUTE</td> <td>OTH-ER</td> </tr> <tr> <td>E.L. EACH ACCIDENT</td> <td>\$ 1,000,000</td> </tr> <tr> <td>E.L. DISEASE - EA EMPLOYEE</td> <td>\$ 1,000,000</td> </tr> <tr> <td>E.L. DISEASE - POLICY LIMIT</td> <td>\$ 1,000,000</td> </tr> </table>	PER STATUTE	OTH-ER	E.L. EACH ACCIDENT	\$ 1,000,000	E.L. DISEASE - EA EMPLOYEE	\$ 1,000,000	E.L. DISEASE - POLICY LIMIT	\$ 1,000,000
PER STATUTE	OTH-ER														
E.L. EACH ACCIDENT	\$ 1,000,000														
E.L. DISEASE - EA EMPLOYEE	\$ 1,000,000														
E.L. DISEASE - POLICY LIMIT	\$ 1,000,000														

DESCRIPTION OF OPERATIONS / LOCATIONS / VEHICLES (ACORD 101, Additional Remarks Schedule, may be attached if more space is required)

RE: Hoover Forest Preserve - Meadowhawk Lodge Staining Project
 Certificate issued as Evidence of Insurance.

CERTIFICATE HOLDER**CANCELLATION**

Kendall County Forest Preserve District 110 W. Madison Street Yorkville IL 60560	SHOULD ANY OF THE ABOVE DESCRIBED POLICIES BE CANCELLED BEFORE THE EXPIRATION DATE THEREOF, NOTICE WILL BE DELIVERED IN ACCORDANCE WITH THE POLICY PROVISIONS.
	AUTHORIZED REPRESENTATIVE 

To: Kendall County Forest Preserve District Board of Commissioners

From: David Guritz, Director

RE: Forest Foundation of Kendall County – Coordination of Purchases and Volunteer Contributions for Grant-Funded Projects

Date: September 3, 2019

Kendall County Forest Preserve District is working to support completion of two grant-funded projects sponsored by the Forest Foundation of Kendall County.

The Illinois Clean Energy Community Foundation awarded a \$5,500.00 Amenities and Events grant to support completion of the "Hobbit Tunnel" Nature Play Space.

In 2018 this project also received significant contributions from 100+ Women Who Care Oswego -Montgomery-Yorkville and TransCanada.

During the Forest Foundation's September meeting, the Board of Trustees will consider approval of a Waterplay Solutions activator post and base that will control water volume and timing of the proposed raised-stream feature. The quote extended is based on an interlocal contract for cooperative purchasing by the Houston-Galveston Area Council, Texas.

Direction will be requested for the District to enter into the interlocal contract to secure the reduced cost purchase will be presented for discussion at the upcoming Committee of the Whole meeting.

Separately, the Illinois Clean Energy Community Foundation extended a \$5,500.00 Amenities and Events grant to support completion of a trail head kiosk at Fox River Bluffs Forest Preserve. District staff recommends moving forward with the purchase of an identical TK3 kiosk kit from Wilderness Graphics, including interpretive panel graphic design similar to the trail head kiosk installed earlier this year at Little Rock Creek Forest Preserve. As part of this request, District staff recommends extending \$1,425.84 in matching funds to support the purchase.

District staff are also recommends supporting the grant requirements to install interpretive/donor acknowledgement signs at the Hoover Nature Play Space and Hoover Forest Preserve's trail head to provide the public education and insights into the projects, as well as acknowledge partner/funder contributions.

Both projects need to be completed by the October 31, 2019 deadlines as stated in the ICECF grant agreements.

Collectively, the Forest Foundation of Kendall County has raised over \$50,000 over the past 4-years to complete Nature Play Space improvements and wildlife habitat improvement projects at Hoover Forest Preserve.

Recommendations:

- 1. Consider two separate motions to approve the acceptance of donations and volunteer support from the Forest Foundation of Kendall County to complete construction of the "Hobbit Tunnel" Nature Play Space Feature at Hoover Forest Preserve and Trail Head Kiosk feature at Fox River Bluffs Forest Preserve.**
- 2. Consider a motion to extend \$1,425.84 towards the purchase of the Fox River Bluffs interpretive kiosk.**
- 3. Consider a motion to approve the purchase and graphic design of two interpretive Durareader Interpretive Signs from Envirosigns of Salt Lake City, Utah for an amount not-to-exceed \$2,849.75,**



QUOTE

Waterplay Solutions
805 Crowley Ave
Kelowna, British Columbia
V1Y 7G6 Canada

Prepared For: Dave Guritz
Quote No: QUO-01028
Revision: 1
Title: Stephanie's Garden, Yorkville, IL

Phone: 1.250.712.3393
Fax: 1.250.861.4814
Toll Free: 1.800.590.5552 (USA & CAN)
Websites: www.waterplay.com

Quote Date: 8/29/2019
Expiry Date: 11/27/2019
Sales Rep: Kyle Siedlik
Email: kyle.siedlik@waterplay.com

Customer Information

Customer:	Kendall County Forest Preserve District	Bill To:	Kendall County Forest Preserve District
Telephone:	+1 (630) 553-4131		110 W Madison St
Payment Terms:	30% (0 TO% NET 30 (30% to order/70% Nkt 30)		Yorkville IL
Currency:	USD		60560 USA
Project Name:	Stephanie's Garden, Yorkville, IL	Ship To:	Kendall County Forest Preserve District
Freight Terms:			Hoover Forest Preserve 11285 West Fox Road
PO Number:			Yorkville IL
Notes:			60560 USA
HGAC quote		Preship To:	Kendall County Forest Preserve District
			Hoover Forest Preserve 11285 West Fox Road
			Yorkville IL
			60560 USA

LINE ITEMS

Part ID	Qty	Description	Preship	MSRP	Extended Price
002-345	4.00	GS Tulip	N	\$595.00	\$2,380.00
0010-1854	1.00	Activator Power Post Columbi brown (RAL-6028), Green Aquadome	N	\$1,650.00	\$1,650.00
0010-4799	1.00	Activator ECO Base	N	\$5,275.00	\$5,275.00
FREIGHT_US	1.00	Freight USA Valid for 90 days from August 29, 2019	N	\$950.00	\$950.00

MSRP: \$10,255.00

Discount: \$930.50

Total MSRP: \$9,324.50

Deposit Required (30%): \$2,797.35

Waterplay has partnered with Marlin Capital Solutions to provide flexible product financing options to our customers, moving your project from a capital cost to an operational expense.

If interested in financing your aquatic play project, please visit our website at www.waterplay.com/en/marlin-financing-options/ and click the "Calculate a Finance Quote" button to view quote estimates and submit a preliminary application. Our financing expert will get in touch with you to discuss financing details and next steps. Once approved, Marlin will provide the documentation for you to sign with the agreed-upon monthly payment and term. It's really that easy!

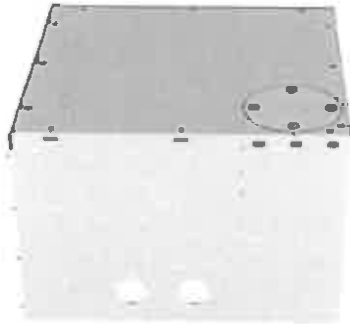

INTEGRATED CONTROLLER
AND MANIFOLD

PERFECT FOR SMALL SPACE DESIGNS!

- ✓ Below-grade controller sets operating hours and four valve manifold turns park on and off
- ✓ Supports up to 40 GPM (151 LPM)
- ✓ Built-in playPHASE™ mount
- ✓ One 1.5" (38mm) water supply line and one 120-volt hardwired electrical line required
- ✓ Anti-slip powder-coating
- ✓ Flush-to-grade installation

COMPATIBLE ACTIVATORS

The Eco Activator Base is compatible with multiple activators. Pick the perfect solution for your space.

POWER POST



SPROUT

FRESTO



MAESTRO

ECO ACTIVATOR BASE

HIGHLIGHTS

Simplify your space! An all-in-one water management solution for small aquatic spaces, the Eco Activator Base combines manifold and controller technology in one flush-to-grade solution.

*Activator sold separately

BEST PRACTICES

Combine the Eco Activator Base with an activator and low flow features up to 40 GPM (151 LPM) for optimal performance and play value. Works best with ground sprays and above-grade features less than 4' (1.22m) to promote ideal water sequencing.

COLOURS

All standard Waterplay colours

ECO 'ACTIVATOR' BASE

0010-4799

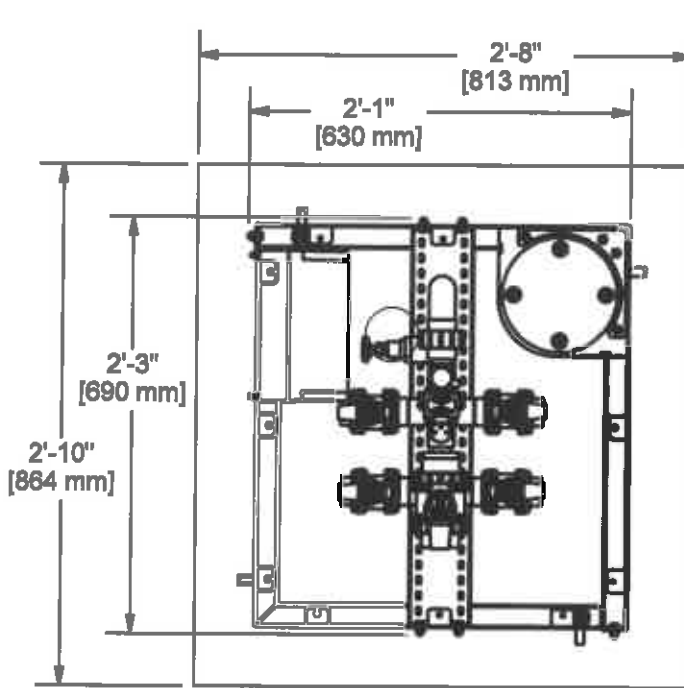

ACTIVATOR SOLD SEPERATELY

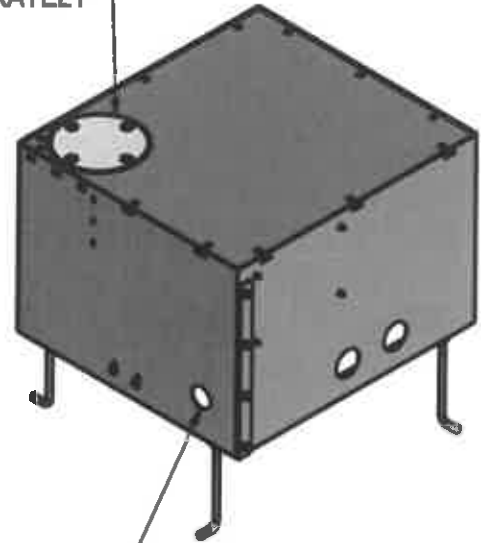

2" OPENING FOR ELECTRICAL SUPPLY (BY OTHER)

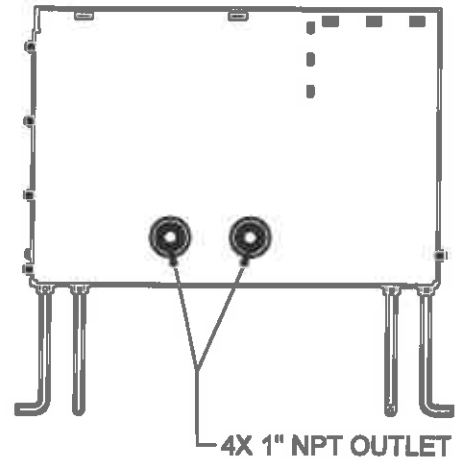
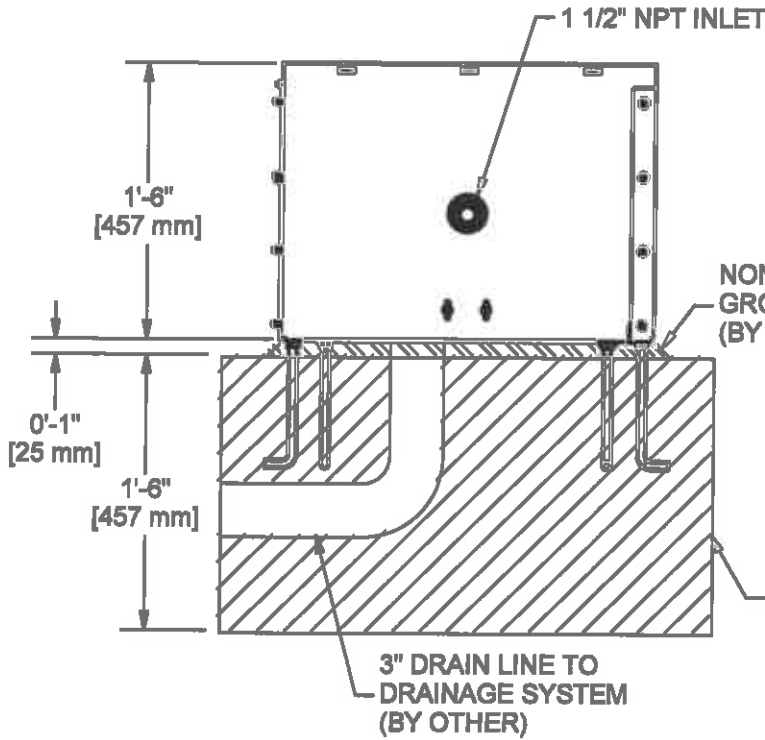

FOOTING (BY OTHER)

4X 1" NPT OUTLET

VOLTAGE / TENSION	12-36 VDC
CURRENT / COURANT	250mA
WIRE SIZE / TAILLE DE FIL	MIN. 2 WIRE 18 AWG + GROUND

INLET / ENTRÉE	1-1/2" F-NPT
ELECTRICAL / ÉLECTRIQUE	1" F-NPT
DRAIN / DRAINER	3"

RECOMMENDED SPRAY AREA / ZONE D'ASPERSION POTENTIELLE			FLOWRATE / DÉBIT D'EAU		COMPONENT INCLUDES: (IF REQUIRED) / INCLUS AVEC LE JEU (SI REQUISÉ)	INITIAL:	
R (ft/mm)	L (ft/mm)	W (ft/mm)	GPM/LPM	PSI/kPa			
-	+	+	+	+	-SERVICE TOOLS / OUTILS -SPRAY NOZZLES / BUSES DE PERFORMANCE	DRAWING ID: 0010-4799	
NOZZLES / BUSES					DIMENSIONAL ACCURACY / PRÉCISION DIMENSIONNELLE +/- 1" [25mm]		SHEET: 1 OF: 1

waterplay Solutions Corp.
 1461B ELLIS STREET
 KELLOWNA, BRITISH COLUMBIA
 CANADA, V1Y 2A3
 P: 250-712-3383 F: 250-861-4814
 E: design@waterplay.com W: waterplay.com

ALL PLANS AND DESIGNS AT ALL TIMES REMAIN THE PROPERTY OF THE WATERPLAY AND CANNOT BE USED OR REPRODUCED WITHOUT WRITTEN PERMISSION.

TOUT LES PLANS ET DESSINS QUE WATERPLAY ONT CONÇUS, LEURS APPARTIENNENT ET NE PEUVENT ÊTRE UTILISÉS OU REPRODUITS SANS AVOIR UNE PERMISSION ÉCRITE DE LEUR PART.

NOTE: REFER TO THE COMPONENT WRITTEN SPECIFICATION DOCUMENT FOR COMPLETE PRODUCT SPECIFICATIONS. WATERPLAY RESERVES THE RIGHT TO CHANGE THIS SPECIFICATION WITHOUT NOTICE.

REFFÉREZ VOUS AU DOCUMENT DE SPÉCIFICATION ÉCRIT POUR LES DÉTAILS COMPLET DU PRODUIT. WATERPLAY A LE DROIT DE CHANGER CES DERNIERS SANS PRÉAVIS.



**INTERLOCAL CONTRACT
FOR COOPERATIVE PURCHASING**

ILC
No.: _____
Permanent Number assigned by H-GAC

THIS INTERLOCAL CONTRACT ("Contract"), made and entered into pursuant to the Texas Interlocal Cooperation Act, Chapter 791, Texas Government Code (the "Act"), by and between the Houston-Galveston Area Council, hereinafter referred to as "H-GAC," having its principal place of business at 3555 Timmons Lane, Suite 120, Houston, Texas 77027, and * _____, a local government, state agency, or a non-profit corporation created and operated to provide one or more governmental functions and services, hereinafter referred to as "End User," having its principal place of business at * _____

WITNESSETH

WHEREAS, H-GAC is a regional planning commission and political subdivision of the State of Texas operating under Chapter 391, Texas Local Government Code; and

WHEREAS, pursuant to the Act, H-GAC is authorized to contract with eligible entities to perform governmental functions and services, including the purchase of goods and services; and

WHEREAS, in reliance on such authority, H-GAC has instituted a cooperative purchasing program under which it contracts with eligible entities under the Act; and

WHEREAS, End User has represented that it is an eligible entity under the Act, that its governing body has authorized this Contract on * _____, and that it desires to contract with H-GAC on the terms set forth below;

NOW, THEREFORE, H-GAC and the End User do hereby agree as follows:

ARTICLE 1: LEGAL AUTHORITY

The End User represents and warrants to H-GAC that (1) it is eligible to contract with H-GAC under the Act because it is one of the following: a local government, as defined in the Act (a county, a municipality, a special district, or other political subdivision of the State of Texas or any other state), or a combination of two or more of those entities, a state agency (an agency of the State of Texas as defined in Section 771.002 of the Texas Government Code, or a similar agency of another state), or a non-profit corporation created and operated to provide one or more governmental functions and services, and (2) it possesses adequate legal authority to enter into this Contract.

ARTICLE 2: APPLICABLE LAWS

H-GAC and the End User agree to conduct all activities under this Contract in accordance with all applicable rules, regulations, and ordinances and laws in effect or promulgated during the term of this Contract.

ARTICLE 3: WHOLE AGREEMENT

This Contract and any attachments, as provided herein, constitute the complete contract between the parties hereto, and supersede any and all oral and written agreements between the parties relating to matters herein.

ARTICLE 4: PERFORMANCE PERIOD

The period of this Contract shall be for the balance of the fiscal year of the End User, which began * _____ and ends * _____. This Contract shall thereafter automatically be renewed annually for each succeeding fiscal year, provided that such renewal shall not have the effect of extending the period in which the End User may make any payment due an H-GAC contractor beyond the fiscal year in which such obligation was incurred under this Contract.

ARTICLE 5: SCOPE OF SERVICES

The End User appoints H-GAC its true and lawful purchasing agent for the purchase of certain products and services through the H-GAC Cooperative Purchasing Program. End User will access the Program through *HGACBuy.com* and by submission of any duly executed purchase order, in the form prescribed by H-GAC to a contractor having a valid contract with H-GAC. All purchases hereunder shall be in accordance with specifications and contract terms and pricing established by H-GAC. Ownership (title) to products purchased through H-GAC shall transfer directly from the contractor to the End User.

(over)

ARTICLE 6: PAYMENTS

H-GAC will confirm each order and issue notice to contractor to proceed. Upon delivery of goods or services purchased, and presentation of a properly documented invoice, the End User shall promptly, and in any case within thirty (30) days, pay H-GAC's contractor the full amount of the invoice. All payments for goods or services will be made from current revenues available to the paying party. In no event shall H-GAC have any financial liability to the End User for any goods or services End User procures from an H-GAC contractor.

ARTICLE 7: CHANGES AND AMENDMENTS

This Contract may be amended only by a written amendment executed by both parties, except that any alterations, additions, or deletions to the terms of this Contract which are required by changes in Federal and State law or regulations are automatically incorporated into this Contract without written amendment hereto and shall become effective on the date designated by such law or regulation.

H-GAC reserves the right to make changes in the scope of products and services offered through the H-GAC Cooperative Purchasing Program to be performed hereunder.

ARTICLE 8: TERMINATION PROCEDURES

H-GAC or the End User may cancel this Contract at any time upon thirty (30) days written notice by certified mail to the other party to this Contract. The obligations of the End User, including its obligation to pay H-GAC's contractor for all costs incurred under this Contract prior to such notice shall survive such cancellation, as well as any other obligation incurred under this Contract, until performed or discharged by the End User.

ARTICLE 9: SEVERABILITY

All parties agree that should any provision of this Contract be determined to be invalid or unenforceable, such determination shall not affect any other term of this Contract, which shall continue in full force and effect.

ARTICLE 10: FORCE MAJEURE

To the extent that either party to this Contract shall be wholly or partially prevented from the performance within the term specified of any obligation or duty placed on such party by reason of or through strikes, stoppage of labor, riot, fire, flood, acts of war, insurrection, accident, order of any court, act of God, or specific cause reasonably beyond the party's control and not attributable to its neglect or nonfeasance, in such event, the time for the performance of such obligation or duty shall be suspended until such disability to perform is removed; provided, however, force majeure shall not excuse an obligation solely to pay funds. Determination of force majeure shall rest solely with H-GAC.

ARTICLE 11: VENUE

Disputes between procuring party and Vendor are to be resolved in accord with the law and venue rules of the State of purchase.

THIS INSTRUMENT HAS BEEN EXECUTED BY THE PARTIES HERETO AS FOLLOWS:

Name of End User (local government, agency, or non-profit corporation)

Mailing Address

City State ZIP Code

By: Signature of chief elected or appointed official

Typed Name & Title of Signatory

Date

Houston-Galveston Area Council
3555 Timmons Lane, Suite 120, Houston, TX 77027

By: _____
Executive Director

Date: _____

**Denotes required fields*

END USER DATA

Please sign and return the Interlocal Contract, along with this completed form, to H-GAC by emailing it to cpcontractfax@h-gac.com or by faxing it to 713-993-2424. The contract may also be mailed to:

H-GAC Cooperative Purchasing Program
P.O. Box 22777, Houston, TX 77227-2777

Name of End User Agency: _____ County Name: _____
(Municipality/County/District/etc.)

Mailing Address: _____
(Street Address/P.O. Box) (City) (State) (ZIP Code)

Main Telephone Number: _____ FAX Number: _____

Physical Address: _____
(Street Address, if different from mailing address) (City) (State) (ZIP Code)

Web Site Address: _____

Official Contact: _____ Title: _____
(Point of Contact for HGACBuy Interlocal Contract) Ph No: _____

Mailing Address: _____ Fx No.: _____
(Street Address/P.O. Box) E-Mail Address: _____

(City) (State) (ZIP Code)

Authorized Official: _____ Title: _____
(Mayor/City Manager/Executive Director/etc.) Ph No.: _____

Mailing Address: _____ Fx No.: _____
(Street Address/P.O. Box) E-Mail Address: _____

(City) (State) (ZIP Code)

Official Contact: _____ Title: _____
(Purchasing Agent/Auditor/etc.) Ph No.: _____

Mailing Address: _____ Fx No.: _____
(Street Address/P.O. Box) E-Mail Address: _____

(City) (State) (ZIP Code)

Official Contact: _____ Title: _____
(Public Works Director/Police Chief etc.) Ph No.: _____

Mailing Address: _____ Fx No.: _____
(Street Address/P.O. Box) E-Mail Address: _____

(City) (State) (ZIP Code)

Official Contact: _____ Title: _____
(EMS Director/Fire Chief etc.) Ph No.: _____

Mailing Address: _____ Fx No.: _____
(Street Address/P.O. Box) E-Mail Address: _____

(City) (State) (ZIP Code)

* denotes required fields

This is a SAMPLE Contract only, NOT for execution.

Wilderness Graphics Inc.
3465 Garber Drive
Tallahassee, FL 32303
8502246414
info@wgl.cc
www.wildernessgraphics.com



Estimate

ADDRESS

2019.0000c Bids

SHIP TO

David Guritz
Kendall County Forest
Preserve District
110 W. Madison Street
Yorkville, IL 60560

ESTIMATE # 01116**DATE 09/03/2019****CUSTOMER EMAIL**

dguritz@co.kendall.il.us

ACTIVITY	DESCRIPTION	QTY	RATE	AMOUNT
TK3	kiosk with space for (1) 3x3' and (1) 2x3' vertical signs; pressure-treated pine with cedar-shingle roof	1	3,245.00	3,245.00
Metal Roof	aluminum roof added to kiosk, choice of colors	1	500.00	500.00
Miscellaneous Item	mending brackets	4	0.00	0.00
Bulletin Case	outdoor lockable bulletin case	1	350.00	350.00
3x3' Permprint	3x3' custom designed and printed Permprint sign on 1/8" aluminum with clear-coat protectant	1	1,378.00	1,378.00
Shipping/Handling			973.61	973.61

TOTAL**\$6,446.61**

Accepted By

Accepted Date



QUOTE

Kendall County Forest Preserve District
YORKVILLE IL 60560

Date
Aug 27, 2019

Quote Number
QU-1935

Reference
SR: Tina

Interpretive Graphics /
EnviroSIGNS
3590 E Summerhill Dr
SALT LAKE CITY UT
84121
USA 888-492-5377

TWO 24 H x 42 W Durareader with Design and Forest Green Base

Description	Quantity	Unit Price	Discount	Tax	Amount USD
Traditional, 45-degree, in-ground, exhibit base with frame for a 24"hx42"wx1/8" panel. Forest Green powder coated aluminum.	2.00	663.41		Tax Exempt	1,326.82
24"hx42"wx1/8" thick DuraReader panel (exterior CHPL)	2.00	251.69		Tax Exempt	503.38
Layout design and preparation of production-ready digital files. Sign text and high-resolution images are to be provided to Interpretive Graphics / EnviroSIGNS. PDF files will be provided for review and approval.	2.00	300.00		Tax Exempt	600.00
Digital Pre-press Proof for review and approval of content. Changes at this stage may incur file replacement fees.	1.00	0.00			0.00
DuraReader Production Setup	1.00	100.00		Tax Exempt	100.00
Wrapping and Crating Products are wrapped, packaged, and/or crated to protect during shipment	1.00	45.00	100.00%		0.00
Packaging and Standard Shipping to zip code 60560 (no special services included)	1.00	319.55		Tax Exempt	319.55
Subtotal (includes a discount of 45.00)					2,849.75
TOTAL USD					2,849.75

To: Kendall County Forest Preserve District Board of Commissioners

From: David Guritz, Director

RE: Project #08-19-002 - Purchase of Seed Mix from Genesis Nursery of Tampico, Illinois

Date: September 3, 2019

Genesis Nursery of Tampico Illinois extended the low-bid for the purchase of prairie seed mix for cropland conversion and prairie restoration projects at Fox River Bluffs and Hoover Forest Preserves.

District staff recommends moving forward with placement of an initial order of 22.5-acres of seed mix for the Hoover Forest Preserve restoration at a base-bid cost of \$930.33 per acre, and total purchase of \$20,932.43.

The District's remaining purchase of seed mix for the Fox River Bluffs cropland conversion project will be postponed pending the announcement of an award and subsequent grant agreement with the Illinois Department of Natural Resources expected in October.

Once the grant agreement is in place, the District can move forward with the purchase of the remaining seed mix which will be considered as the District's required match.

Recommendation:

Consider a motion to approve an initial order of 22.5-acres of prairie seed mix from Genesis Nursery of Tampico, Illinois for \$930.33 per acre (\$20,932.43 total) for enhancement of the Hoover core prairie area at Hoover Forest Preserve, with a \$7,650.00 anticipated reimbursement from the ICECF as part of the District's awarded K-12 Pollinator grant.

Detailed Specifications

The KENDALL COUNTY FOREST PRESERVE DISTRICT is seeking proposals for the purchase of:

Pollinator Mix Pure Live Seed for 59-acres

GENERAL CONDITIONS

DESCRIPTION OF PROJECT: This project consists of the conversion of thirty-six and one half (36.5) acres of cropland to prairie habitat at Fox River Bluffs Forest Preserve, and enhancement of twenty-two and one half (22.5) acres of prairie habitat at various preserve areas (**EXHIBIT A – MATERIALS SCHEDULE**).

This project is funded in part by a grant from the Illinois Clean Energy Community Foundation in connection with the Forest Foundation of Kendall County's "Hoover Community Stewardship Restoration Project," with the stated goal of increasing nectar sources and milkweed species' abundance to establish Monarch butterfly (*Danaus plexippus*) habitat towards species recovery.

The cropland conversion area at Fox River Bluffs Forest Preserve will have produced soybeans each of the past two years at the time of restoration. This project will commence soon after the 2019 soybean harvest in early to mid-November. Pure Live Seed will be scheduled for delivery no later than November 15, 2019.

The Supplier will take special care in purchasing seed mixes from reputable vendors.

Purchased seed mix will consist of 100% Pure Live Seed (PLS) in the quantities and percentages detailed in the **EXHIBIT A – MATERIALS SCHEDULE**.

Supplier will source the seed mix originating from within the following The Nature Conservancy Ecoregions:

EXHIBIT B: THE NATURE CONSERVANCY'S ECOREGION MAP

Ecoregion 36: Central Tallgrass Prairie and Ecoregion 46: Prairie-Forest Border

Supplier is responsible for certifying that the seed mix supplied is not contaminated by Palmer amaranth (*Amaranthus palmeri*). If the seed mix purchased from the Supplier is found to be contaminated with seed from this species as evidenced by emergence of this species within the Fox River Bluffs Forest Preserve restoration area footprint, Supplier shall compensate the District for the full expense of mechanical control and full eradication of Palmer amaranth (*Amaranthus palmeri*) within the contaminated area.

**Project #19-08-002
Purchase of 59-acres of Pollinator Mix PLS**

All questions regarding this Call for Proposals must be submitted to the Kendall County Forest Preserve District at least seven business days prior to the bid submittal deadline. Any questions received shall be answered at the discretion of the Kendall County Forest Preserve District. Replies will be issued to all bidders of record in writing and will become part of the Call for Proposals Documents. Questions will not be responded to by oral clarification. Oral clarifications or interpretations shall be without legal effect.

All proposals must be received at the Kendall County Forest Preserve District Headquarters located at 110 W. Madison Street, Yorkville, IL 60560 by Wednesday, August 28, 2019 at 10:00 am to be considered.

Project #19-08-002
Purchase of 59-acres of Pollinator Mix PLS

EXHIBIT A: MATERIALS SCHEDULE

KENDALL COUNTY FOREST PRESERVE DISTRICT
PROJECT #08-19-002 - EXHIBIT A MATERIALS SCHEDULE
SEED MIX REQUIRED - 59.0 ACRES

KENDALL CO. FPD, POLLINATOR SEED MIX, 59-ACRES

FORBS							
Description	% by wt.	OZ PER ACRE	POUNDS FOR 59-ACRES	# SEEDS PER ACRE	# SEEDS PER 59-ACRES	/sq. ft.	% by ct.
Allium stellatum (Prairie Onion)	0.963	1	3.6875	11,000	649,000	0.3	0.15
Asclepias incarnata (Rose Milkweed)	1.925	2	7.375	9,600	566,400	0.2	0.13
Asclepias syriaca (Common Milkweed)	1.444	1.5	5.53125	6,000	354,000	0.1	0.08
Asclepias tuberosa (Butterfly Weed)	0.963	1	3.6875	4,300	253,700	0.1	0.06
Asclepias verticillata (Whorled Milkweed)	1.925	2	7.375	22,000	1,298,000	0.5	0.31
Aster laevis (Smooth Blue Aster)	0.963	1	3.6875	55,000	3,245,000	1.3	0.76
Aster lateriflorus (Calico Aster)	0.481	0.5	1.84375	125,000	7,375,000	2.9	1.74
Aster novae-angliae (New England Aster)	0.963	1	3.6875	80,000	4,720,000	1.8	1.11
Baptisia alba (White Wild Indigo)	0.481	0.5	1.84375	850	50,150	0	0.01
Chamaecrista fasciculata (Partridge Pea)	4.813	5	18.4375	13,500	796,500	0.3	0.19
Cirsium discolor (Pasture Thistle)	0.481	0.5	1.84375	3,200	188,800	0.1	0.04
Coreopsis lanceolata (Lance-leaf Coreopsis)	2.888	3	11.0625	60,000	3,540,000	1.4	0.83
Dalea purpurea (Purple Prairie Clover)	2.888	3	11.0625	45,000	2,655,000	1	0.62
Echinacea pallida (Pale Purple Coneflower)	2.888	3	11.0625	15,600	920,400	0.4	0.22
Echinacea purpurea (Purple Coneflower)	1.925	2	7.375	13,200	778,800	0.3	0.18
Eryngium yuccifolium (Rattlesnake Master)	1.925	2	7.375	15,000	885,000	0.3	0.21
Gaura longiflora (Large-flowered Gaura)	0.481	0.5	1.84375	1,350	79,650	0	0.02
Helianthus pauciflorus (Showy Sunflower)	0.241	0.25	0.921875	1,000	59,000	0	0.01
Lespedeza capitata (Round-headed Bush Clover)	0.481	0.5	1.84375	4,000	236,000	0.1	0.06
Liatis ligulistylis (Meadow Blazing Star)	1.925	2	7.375	20,000	1,180,000	0.5	0.28
Liatis pycnostachya (Prairie Blazing Star)	1.925	2	7.375	22,000	1,298,000	0.5	0.31
Lobelia siphilitica (Great Blue Lobelia)	0.963	1	3.6875	500,000	29,500,000	11.5	6.94
Monarda fistulosa (Wild Bergamot)	0.481	0.5	1.84375	35,000	2,065,000	0.8	0.49
Parthenium integrifolium (Wild Quinine)	0.241	0.25	0.921875	1,750	109,250	0	0.02
Penstemon digitalis (Foxglove Beardtongue)	0.963	1	3.6875	130,000	7,670,000	3	1.80
Pycnanthemum verticillatum var. pilosum (Hairy Mountain Mint)	1.925	2	7.375	370,000	21,830,000	8.5	5.14
Pycnanthemum virginianum (Mountain Mint)	0.481	0.5	1.84375	110,000	6,490,000	2.5	1.53
Ratibida pinnata (Yellow Coneflower)	0.481	0.5	1.84375	15,000	885,000	0.3	0.21
Rudbeckia hirta (Black-eyed Susan)	5.776	6	22.125	552,000	32,568,000	12.7	7.66
Rudbeckia triloba (Brown-eyed Susan)	0.241	0.25	0.921875	8,500	501,500	0.2	0.12
Scrophularia marilandica (Late Figwort)	0.606	0.63	2.323125	107,100	6,318,900	2.5	1.49
Solidago juncea (Early Goldenrod)	0.481	0.5	1.84375	145,000	8,555,000	3.3	2.01
Solidago speciosa (Showy Goldenrod)	0.481	0.5	1.84375	47,500	2,802,500	1.1	0.66
Tradescantia ohioensis (Ohio Spiderwort)	2.888	3	11.0625	24,000	1,416,000	0.6	0.33
Verbena stricta (Hoary Vervain)	0.963	1	3.6875	28,000	1,652,000	0.6	0.39
Veronicastrum virginicum (Culver's Root)	0.481	0.5	1.84375	400,000	23,600,000	9.2	5.55
Zizia aurea (Golden Alexanders)	2.888	3	11.0625	33,000	1,947,000	0.8	0.46
Totals for FORBS :	53.312	55.38	204.2138	3,034,450	179,032,550	69.7	42.13

TREES, SHRUBS & VINES

Description	% by wt.	OZ PER ACRE	POUNDS FOR 59-ACRES	# SEEDS PER ACRE	# SEEDS PER 59-ACRES	/sq. ft.	% by ct.
Amonpa canescens (Lead Plant)	0.963	1	3.6875	16,000	944,000	0.4	0.22
Totals for TREES, SHRUBS & VINES :	0.963	1	3.6875	16,000	944,000	0.4	0.22

GRASSES, SEDGES & RUSHES

Description	% by wt.	OZ PER ACRE	POUNDS FOR 59-ACRES	# SEEDS PER ACRE	# SEEDS PER 59-ACRES	/sq. ft.	% by ct.
Bouteloua curtipendula (Side-oats Grama PLS)	15.402	16	59	96,000	5,664,000	2.2	1.33
Elymus canadensis (Canada Wild Rye PLS)	6.739	7	25.8125	36,400	2,147,600	0.8	0.51
Juncus dudleyi (Dudley's Rush)	0.963	1	3.6875	3,200,000	188,800,000	73.5	44.43
Koeleria macrantha (June Grass PLS)	2.407	2.5	9.21875	500,000	29,500,000	11.5	6.94
Schyzachyrium scoparium (Little Bluestem PLS)	15.402	16	59	240,000	14,160,000	5.5	3.33
Sporobolus heterolepis PLS (Prairie Dropseed PLS)	4.813	5	18.4375	80,000	4,720,000	1.8	1.11
Totals for GRASSES, SEDGES & RUSHES :	45.726	47.5	175.1563	4,152,400	244,991,600	95.3	57.65
Totals for this mix :	100.000	103.88	383.0575	7,202,850	424,968,150	165.4	100.00

Seeding rate: 165.4 seeds per Sq. ft.

Seed Mix Source Credit:
Prairie Moon Nursery
32115 Prairie Lane
Winona, MN 55987
866 417-8156
www.prairiemoon.com

**Exhibit B: The Nature Conservancy's Ecoregions Map
 Seed Sourcing Allowed from Ecoregions 36 and 46 only**

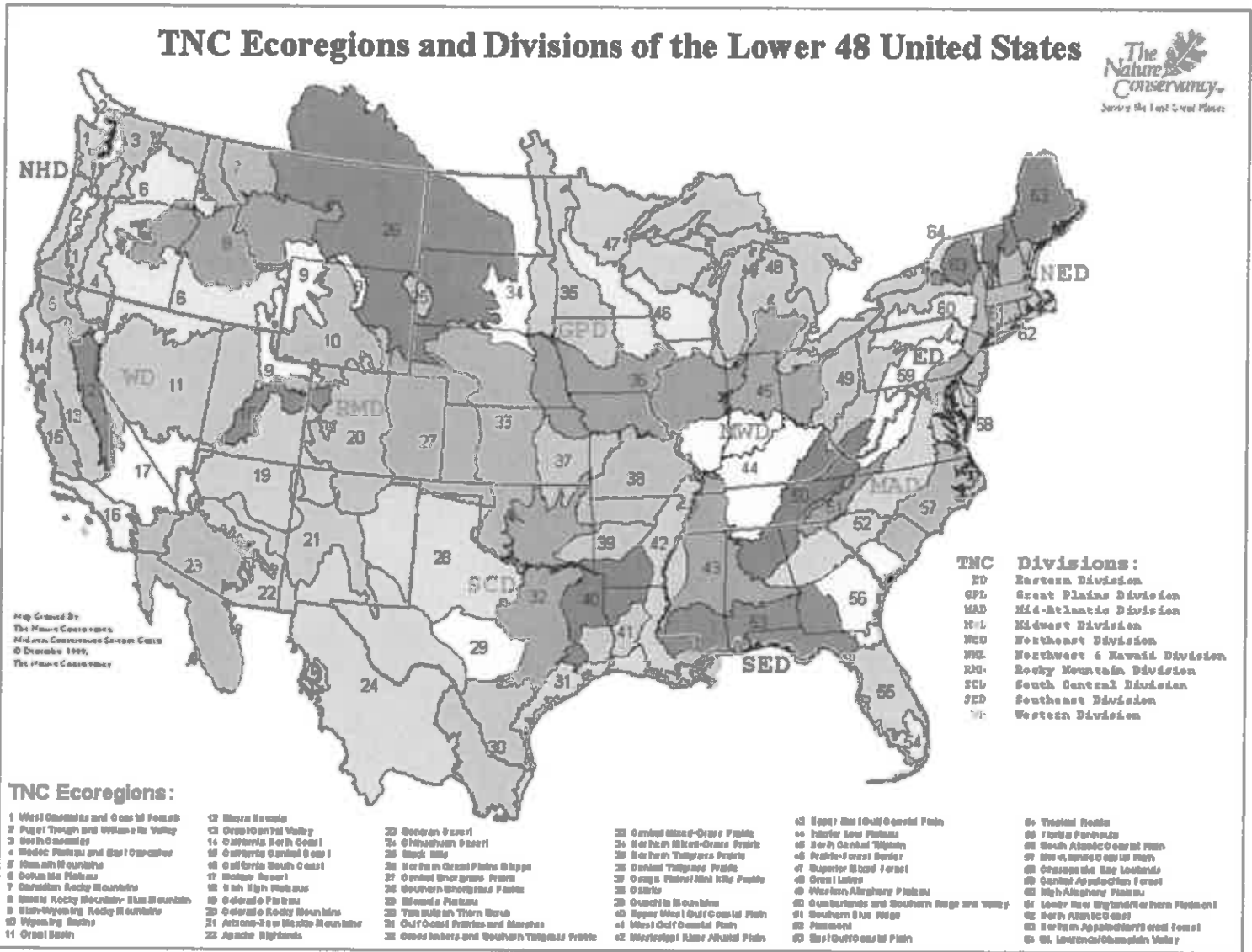

Project #19-08-002
Purchase of 59-acres of Pollinator Mix PLS

The Kendall County Forest Preserve District is exempt from Federal Excise Tax, Illinois Retailers' Occupational Tax and Transportation taxes, therefore these taxes are not to be included in the Bid Proposal.

The prices set forth herein are in agreement with all Federal, State and Local Laws, Rules, Ordinances and Regulations.

By submitting this bid, the Bidder agrees to the following Terms and Conditions:

Duration of Bid Offer. Bidder agrees to be bound to the terms of its bid for a period of sixty (60) calendar days after the Bid Opening Date.

Compliance with Law. Bidder agrees to comply with all applicable federal, state and local laws and regulatory requirements and to secure such licenses as may be required for its employees and to conduct business in the state, municipality, county and location. Such obligation includes, but is not limited to, environmental laws, civil rights laws, prevailing wage and labor laws.

Remedies. If the Kendall County Forest Preserve District is required to take legal action to enforce performance of any of the terms, provisions, covenants and conditions of this purchase, and by reason thereof, the Kendall County Forest Preserve District is required to use the services of an attorney, then the Kendall County Forest Preserve District shall be entitled to reasonable attorneys' fees, court costs, expenses and expert witness fees incurred by the Kendall County Forest Preserve District pertaining thereto and in enforcement of any remedy, including costs and fees relating to any appeal. This purchase shall be construed in accordance with the law and Constitution of the State of Illinois. The parties agree that the venue for any legal proceedings between them shall be the Circuit Court of Kendall County, Illinois, Twenty-Third Judicial Circuit, State of Illinois.

Certification. Bidder certifies that Bidder, its parent companies, subsidiaries, and affiliates are not barred from entering into this transaction as a result of a violation of either 720 ILCS 5/33E-3 or 5/33E-4 (bid rigging or bid rotating) or as a result of a violation of 820 ILCS 130/1 et seq. (the Illinois Prevailing Wage Act). Bidder further certifies by signing the bid documents that Bidder, its parent companies, subsidiaries, and affiliates have not been convicted of, or are not barred for attempting to rig bids, price-fixing or attempting to fix prices as defined in the Sherman Anti-Trust Act and Clayton Act. 15 U.S.C. § 1 et seq.; and has not been convicted of or barred for bribery or attempting to bribe an officer or employee of a unit of state or local government or school district in the State of Illinois in that Officer's or employee's official capacity. Nor has Bidder made an admission of guilt of such conduct that is a matter of record, nor has any official, officer, agent, or employee of the company been so convicted nor made such an admission.

Conflict of Interest. Bidder affirms no Kendall County Forest Preserve District officer or elected official has a direct or indirect pecuniary interest in Bidder or this purchase, or, if any Kendall County Forest Preserve District officer or elected official does have a direct or indirect pecuniary interest in Bidder or this purchase, that interest, and the procedure followed to effectuate this purchase has and will comply with 50 ILCS 105/3.

Independent Contractor. It is understood and agreed that Bidder is an independent contractor and is not an employee of, partner of, agent of, or in a joint venture with the Kendall County Forest Preserve District.

Warranties. No warranties implied or explicit may be waived or denied.

Right to Reject and/or Request Clarification. The Kendall County Forest Preserve District reserves the right to reject any or all proposals and waive any or all irregularities. The Kendall County Forest Preserve District retains the authority to eliminate any service features that are deemed too costly or unnecessary. The Kendall County Forest Preserve District may seek clarification from Bidder at any time and failure to respond promptly is cause for rejection.

No Right to Award. Submission of a bid confers no rights on the Bidder to selection. This bidding process is for the Kendall County Forest Preserve District's benefit only and is intended to provide the Kendall County Forest Preserve District with competitive information to assist in selection of services. All decisions on compliance, evaluation, terms and conditions shall be made solely at the Kendall County Forest Preserve District's discretion.

Compliance with Terms. The Bidder's failure to agree to the terms and conditions of this Call for Proposals or to otherwise meet the mandatory requirements will result in the disqualification of the Bidder's proposal from further consideration as an unresponsive bid.

Project #19-08-002
Purchase of 59-acres of Pollinator Mix PLS

Bid Proposal

Bid Proposal For: Project # 19-08-002 - Purchase of 59-acres of Pollinator Mix PLS
Date: 8/26/2019
Bid Submitted by: Genesis Nursery, Inc.
Business Name: Genesis Nursery, Inc.
FEIN#: 36-3832247
Contact Person: Will Powers
Address: PO Box 9
Address: 23200 Hurd Road
City, State, Zip: Tampico, IL. 61283
Telephone Number(s) : (815) 438.2220 ()
Fax Number: (815) 438.2222

Having carefully examined the Detailed Specifications, Exhibits, Terms and Conditions, and other documentation included with the Call for Proposals for the work entitled:
19-08-002 consisting of the purchase of 59-acres of Pollinator Seed Mix, the undersigned hereby agree(s) to furnish materials in accordance with the Call for Proposals as noted.

TOTAL COST: \$ 54,889.47
(FIGURES)

TOTAL COST: Fifty-four Thousand Eight hundred eighty-nine and 47/100
(WORDS)

Unit Costs:

Cost for each additional half-acre seed mix delivered: \$ ~~945.33~~ Revised to \$480.17
Cost for each additional 1-acre seed mix delivered: \$ 950.33

***Include freight, delivery, disposal, and any other charges in the base bid and unit prices.**

Project #19-08-002
Purchase of 59-acres of Pollinator Mix PLS

Corporate Officers

Owner / President: Kathy Lubbs

Secretary: Billie Jo Egan

Signature of Owner / President Kathy Lubbs

Attest: Billie Jo Egan (Corporate Secretary)

Subscribed and sworn to before me this 26th DAY OF August, 2019

My Commission Expires:

x Stormy Douglas
Notary Public Signature



Notary Seal

Project #19-08-002
Purchase of 59-acres of Pollinator Mix PLS

Addendum Receipt

The receipt of the following addenda to the Call for Proposals is acknowledged:

Addendum No. _____ Date: _____

2019.08.08

Bidder's Information

Completion of this form is required

Identify what seed suppliers, if other than the Bidder's own firm, will be selected to source the required seed mix stock, including name, address, contact information, and location of seed source(s). Name the consulting/sub-contract firms and addresses. How long have you been working with each consulting/sub-contractor firm? What experience do you have working together on similar projects?

NA.

Exceptions to Specifications

IMPORTANT

Does the equipment or material offered comply with the Specifications?

YES _____ NO X

If your answer is "NO" explain below each instance where the equipment or material offered does NOT comply with the specifications:

- 1.) *Allium stellatum* is not available. Sub *Allium cernuum*.
- 2.) *Cirsium discolor* is not available. Sub *Euphorbia corollata*.
- 3.) *Gaura longiflora* is not available. Sub *Oenothera biennis*.
- 4.) *Liatris ligulistylis* is not available. Sub *Liatris aspera*.
- 5.) *Symphoricarpon latiflorum* is not available. Sub *Ageratina altissima*.

Please Note: Some of the above referenced species may be available in partial quantity. However, we cannot supply any in full quantity.

Bidder's Experience

Completion of this form is required

Bidder shall provide a comprehensive list of projects where Bidder has provided similar work as required by this contract. Bidder may attach additional pages, if necessary.

Year: 2018 Project: Henneberry Woods, Kendall County

Description: Genesis Nursery, Inc. supplied the seed material put down by Semper Fi Land, Inc. for use on this project

Owner's Name: Kendall County Forest Preserve District

Address: 110 W. Madison St., Yorkville, IL 60560

Contact: Dave Guritz

Telephone Numbers: 630.553.4131

Email Address(es): dguritz@co.kendall.il.us

Year: 2018 Project: Fall 2018 Seed Order

Description: Genesis Nursery, Inc. supplied the native seed material used by the FPD of Will County for their Fall 2018 seed order. Our seed was put down on multiple sites throughout the district.

Project #19-08-002
Purchase of 59-acres of Pollinator Mix PLS

Owner's Name: Forest Preserve District of Will County

Address: 17540 W. Laramay Rd., Joliet, IL 60433

Contact: Julianne Mason

Telephone Numbers: 815. 722, 5373

Email Address(es): jimason@fpdwc.org

Year: 2018 Project: Purchase and Delivery of Native Seed 2018
for Habitat Restoration - Multiple Preserves

Description: Genesis Nursery, Inc. supplied native seed
material used by the Lake County FPD on multiple
sites throughout the district.

Owner's Name: Lake County Forest Preserves

Address: 1899 West Winchester Rd., Libertyville, IL 60048

Contact: Matt Ueltzen

Telephone Numbers: 847. 968. 3240

Email Address(es): mueltzen@lcfpd.org

Hi David,

I realized that I provided an incorrect number for the additional half-acre supply of our seed mix. If an additional half-acre of the seed mix is ordered it will cost \$480.17 delivered.

Thank you,

Will

Genesis Nursery, Inc.

P- 815.438.2220

On 2019-08-28 06:06, David Guritz wrote:

Attention: 1) Cindy Whitehead c/o Taylor Creek Restoration Nursery
- Applied Ecological Services, Broadhead, WI

2) Will Powers - Genesis Nursery Inc., Tampico, IL

Good morning:

Attached, please find the bid opening results from earlier this morning. Two sealed bids were submitted for consideration within the required timeframe. The bid opening was held at 10:00 am on Wednesday, August 28, 2019 at the Kendall County Historic Courthouse, 110 W. Madison St. Yorkville, IL 60560.

Genesis Nursery, Inc. of Tampico, Illinois submitted the apparent qualified low bid for the seed mix purchase.

Additionally, while both firms indicated a need for substitutions, Genesis Nursery indicated that seed source will be exclusively provided directly from the nursery with source location within the required ecoregions specified.

Thank you for your participation.

Sincerely,

Dave Guritz

Director

Kendall County Forest Preserve District

(630) 553-4131

dguritz@co.kendall.il.us

To: Kendall County Forest Preserve District Board of Commissioners

From: David Guritz, Director

RE: Hoover Road Repairs – Crack Filling

Date: September 3, 2019

Three quotes were received to complete repairs of Hoover Road (asphalt paving crack filling).

Of the three quotes submitted, All Pavement Paving and Concrete of Aurora extended the lowest quote at \$620.00 per 1,000 lineal feet for crack filling.

The motion for consideration will allow for up to 2,000 feet of asphalt cracks to be addressed, with final payment based on field measurements.

Recommendation:

Consider a motion to approve a proposal from All Pavement Paving and Concrete of Aurora, Illinois for an amount not-to-exceed \$1,240,00.

August 22, 2019

Kendall County Forest Preserve District

David Guritz, Executive Director

630-553-4131 (office) dguritz@co.kendall.il.us

RE: Request for Additional Information: KCFPD Asphalt Repair Work with Alternate Quote for Concrete at Harris Forest Preserve Garbage Dumpster Approach

In order to compare quotes received, additional information is needed by end of day August 28, 2019:

Contractor Name: All Pavement Paving-Concrete

Contractor Address: 2111 Plum St. Suite 276 Aurora

For the Hoover Forest Preserve – Hoover Road Crack Filling:

1. Please update base quote as needed for 1,000 lineal feet of crack filling (1/4 inch or wider), or indicate no change in quoted price:

\$ 620.00

\$ 62.00 Unit cost for each additional 100' (required)

For the Harris Forest Preserve Parking Lot and Shop Area Drive Repair:

1. Please update base quote as needed for 5" asphalt (Type N50) for the garbage dumpster area approach, or indicate no change in quoted price.

\$ 9,000

2. Please provide an alternate quote for this area to include removal of existing asphalt, base regrading, and installation of 5" of 4,000 PSI concrete with wire mesh reinforcement, or indicate no change in quoted price.

\$ nc

For the Blackberry Creek Forest Preserve Trail Repair Project:

1. Please update base quote as needed to include 3" asphalt resurfacing (Type N50), with butt jointing at transition areas, or indicate no change in quoted price:

nc \$6.50 sq ft Unit cost for each additional 10' (required)

Notes:

All quotes subject to payment of prevailing wages.

This information requested will be added and included as an addendum to each initial proposal received.

Michael Spencer VP of operations

Contact / Signature



PROPOSAL

19-218

DATE 8/4/19

PAGE 1 OF 2

CUSTOMER: KENDALL COUNTY FOREST PRESERVE DISTRICT

PROJECT ADDRESS: VARIOUS LOCATIONS

HARRIS FOREST PRESERVE – HOOVER FOREST PRESERVE – BLACKBERRY CREEK FOREST PRESERVE

HARRIS FOREST PRESERVE

ASPHALT PAVEMENT REMOVAL AND REPLACEMENT WITH ADDED STONE BASE

R&R UP TO 1,000 SQ FT IN APPROX 2 AREAS

- 1) REMOVE PAVEMENT TO EXPOSE STONE BASE**
- 2) FINE GRADE AS NEEDED TO PROVIDE PROPER COMPACTION USING 8-10 TON DUAL VIBRATING ROLLERS**
- 3) ADJUST ALL STORM DRAINS IN DESIGNATED AREAS AS NEEDED**
- 4) APPLY CSS-1 LIQUID ASPHALT PRIMER AT .25 GALLON PER SQ YD RATE**
- 5) INSTALL 1.5" HMA BINDER COURSE OVER THE ENTIRE DESIGNATED AREA AND COMPACT WITH 8 TON DUAL DRUM ROLLER**
- 6) INSTALL 1.5" HMA SURFACE COURSE OVER THE ENTIRE DESIGNATED AREA AND COMPACT WITH 8 TON DUAL DRUM ROLLER**

TOTAL COST FOR ABOVE SCOPE

\$6,000.00

PCC OPTION REMOVAL AND REPLACEMENT WITH ADDED STONE BASE

R&R UP TO 1,000 SQ FT IN APPROX 2 AREAS

- 1) REMOVE PAVEMENT TO EXPOSE STONE BASE**
- 2) FINE GRADE AS NEEDED TO PROVIDE PROPER COMPACTION USING 8-10 TON DUAL VIBRATING ROLLERS**
- 3) POUR 4,000 PSI CONCRETE WITH WIRE MESH REINFORCEMENT AT 5"**

TOTAL COST FOR ABOVE SCOPE

\$8,500.00

HOOVER FOREST PRESERVE

ASPHALT PAVEMENT CRACK FILLING

ROUT AND FILL UP TO 10,000 LN FT

- 1) CLEAN APPROXIMATELY 10,000 LINEAR FEET OF QUARTER INCH AND WIDER SINGLE TRANSVERSE AND LONGITUDINAL CRACKS WITH COMPRESSED AIR AND BROOMS**
- 2) SEAL CRACKS WITH HOT POURED CRACK SEALANT OVER APPROXIMATELY 10,000 LINEAR FEET**

TOTAL COST FOR ABOVE SCOPE

\$5,800.00

BLACKBERRY CREEK FOREST PRESERVE

PAVE OVER EXISTING HMA TRAIL

PAVE UP TO 390 LN FT IN APPROX (4) AREAS

- 1) APPLY CSS-1 LIQUID ASPHALT PRIMER AT .25 GALLON PER SQ YD RATE**
- 2) INSTALL 3" HMA SURFACE COURSE OVER THE ENTIRE DESIGNATED AREA AND COMPACT WITH 8 TON DUAL DRUM ROLLER**

TOTAL COST FOR ABOVE SCOPE

\$25,350.00



PROPOSAL

19-218

DATE 8/4/19

PAGE 2 OF 2

CUSTOMER: KENDALL COUNTY FOREST PRESERVE DISTRICT

PROJECT ADDRESS: VARIOU S LOCATIONS

HARRIS FOREST PRESERVE – HOOVER FOREST PRESERVE – BLACKBERRY CREEK FOREST PRESERVE

JOB NOTES: PLEASE REVIEW THE OUTLINED MAP, THIS MAP IS OUR PLAN OF ATTACK FOR THIS PROJECT.
PRICE DOES NOT INCLUDE ANY UNDERCUT —Add on cost for undercut would be billed at \$80.00 per cubic yard
ALL VEHICLE MUST BE REMOVED FROM THE DESIGNATED AREA PRIOR TO 7AM FOR EACH DESIGNATED SECTION.
PLEASE HAVE A TOW TRUCK ONSITE TO RELOCATE ANY VEHICLE
A WAIT TIME CHARGE OF \$250.00 PER QUARTER HOUR IF ALL PAVEMENT IS FORCED TO WAIT FOR CARS TO BE RELOCATED
EACH SECTION TO TAKE NO MORE THAN (1-2) DAYS- THE AREA TO REMAINED CLOSED UNTIL OPENED UP BY AN ALL PAVEMENT EMPLOYEE
WORKER TO BE PAID PREVAILING WAGES
BALANCE DUE 30 DAYS UPON COMPLETIONS OF THIS PROJECT

PLEASE SEND INSURANCE REQUIREMENT INFORMATION

UPON THE SIGNING OF THIS PROPOSAL WE WILL SUBMIT OUR APPLICATION TO THE VILLAGE FOR PERMIT AS NEEDED

SIGN BELOW IF APPROVED:

DATE: _____

**PROPOSAL SUBMITTED BY: MICHAEL SPENCER VP OPERATION
630-442-4305 CELL**

**ALL PAVEMENT PAVING - CONCRETE, INC.
PO BOX 1123 WHEATON IL 60187**